



## Husky® Model 005969 Swivel Safe-T-Break® Combination for truck and high volume fueling.

- Multi-plane, full 360° spherical rotation for easy movement of nozzle.
- Swivel Sync® feature to prevent separation failure in the 90° position.
- High strength step shoulder bearing diameters and impact absorbing stops.
- Dynamic seals have double o-ring construction for long life and low temperature performance.
- Separates at less than 325 lbf / 1,445.6 N which minimizes backlash force of separations, reducing damage to equipment.
- 008015A and 008985A separate at less than 300 lbf / 1,334.5 N.
- Safe-T-Break® is reconnectable and retains UL listing after reconnecting.
- Dual check valves stop fuel in both directions.
- Internal pressure balancing chamber prevents “line shock” nuisance separations.
- Compatible with Ethanol blends through E10.
- Compact and light weight for easy handling.
- Easier to reconnect when installed at the nozzle.
- Eliminates the need for a whip hose

### Swivel/Safe-T-Break® Combination

MODEL NO.	DESCRIPTION	SHIPPING WEIGHT LBS (KG)
005969	1" NPT M x 1" NPT F Multi-Plane Swivel Reconnectable Safe-T-Break®	1.5 (0.7)
008015	1" BSP M x 1" BSP F Multi-Plane Swivel Reconnectable Safe-T-Break®	1.5 (0.7)
008015A*	1" BSP M x 1" BSP F Multi-Plane Swivel Reconnectable Safe-T-Break® - Atex	1.5 (0.7)
008612	M42 M x 1" BSP F Multi-Plane Swivel Reconnectable Safe-T-Break®	1.5 (0.7)
008614	M34 M x 1" BSP F Multi-Plane Swivel Reconnectable Safe-T-Break®	1.5 (0.7)
008985	1" BSP M x 1" BSP M Multi-Plane Swivel Reconnectable Safe-T-Break®	1.5 (0.7)
008985A*	1" BSP M x 1" BSP M Multi-Plane Swivel Reconnectable Safe-T-Break® - Atex	1.5 (0.7)

### Construction

Body	Aluminum, Zinc Alloy
Seals	Fluorocarbon
Springs	Stainless Steel
Threads	Various

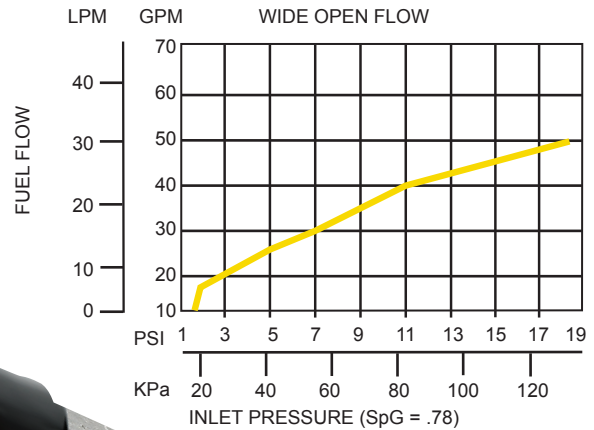

**Husky**

GENERAL FUELING PRODUCTS

# Swivel/STB High Volume

Husky® Model 005969 Swivel Safe-T-Break® Combination for truck and high volume fueling.

## Dimensions and System Options

### Guards

MODEL NO.	DESCRIPTION
006534	Scuff Guard for Safe-T-Break®

### Accessories, Testing and Maintenance

MODEL NO.	DESCRIPTION
007000	Safe-T-Break® Drain Cup

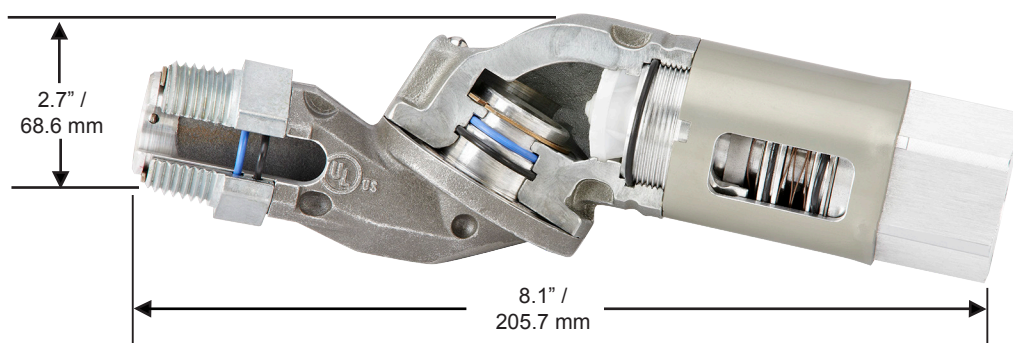

2325 Husky Way • Pacific, MO 63069  
 (800) 325-3558 • Fax (636) 825-7300  
[www.husky.com](http://www.husky.com) • [sales@husky.com](mailto:sales@husky.com)

MADE IN THE U.S.A. 