

All Husky® Safe-T-Breaks® stop the flow of fuel on both sides of the separation and have passed the demanding UL test requirements on separations without leaking or failing.

- EVR Certified per CARB CP-201.
- High impact resistant polymer housing.
- Two straight screwdrivers used to separate. For easier install and maintenance on other hanging hardware.
- Assurance of proper reconnection using a simple “twist of lock” feature.
- Low scuff housing.
- Stops flow on both sides of break.
- Reconnectable Safe-T-Break® for the vapor assist systems: coaxial hoses with fuel “outside” hose, vapor return “inside” hose.
- Unique vapor valve stops vapors from escaping after a drive away.
- Separates at less than 225 lbs / 1000.9 N to minimize backlash damage.

Vac Assist MAGBREAK®

MODEL NO.	DESCRIPTION	SHIPPING WEIGHT LBS (KG)
008332	MAGBREAK® Coax M34 CK	1.36 (.62)
014592	MAGBREAK® Coax 1.25	1.36 (.62)

Construction

Body	Aluminum
Seals	Fluorocarbon
Springs	Stainless Steel
Threads	8332 = M34 x 1.5 and 14592 = 1-1/4" x 18



VAC ASSIST MAGBREAK®

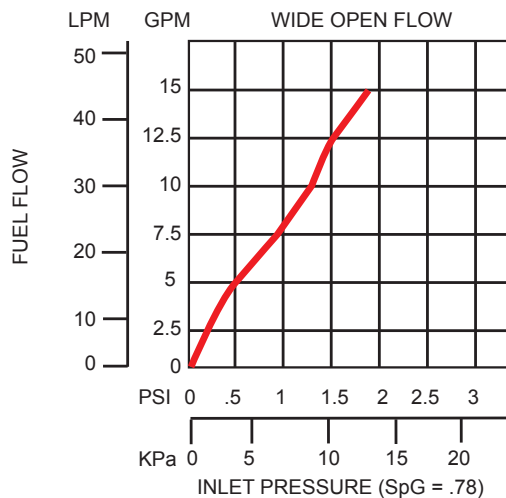
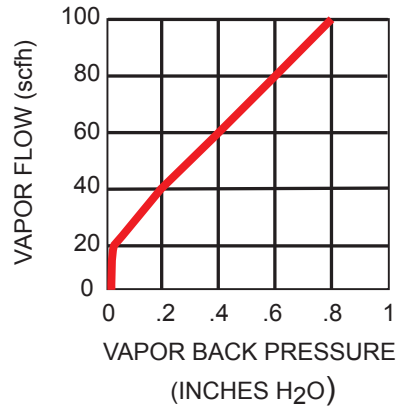

WARNING: Cancer and Reproductive Harm - www.P65Warnings.ca.gov



All Husky® Safe-T-Breaks® stop the flow of fuel on both sides of the separation and have passed the demanding UL test requirements on separations without leaking or failing.

Dimensions

Replacement Parts

MODEL NO.	DESCRIPTION
008632	MAGBREAK LOWER HALF 008332
015416	MAGBREAK LOWER HALF 014592

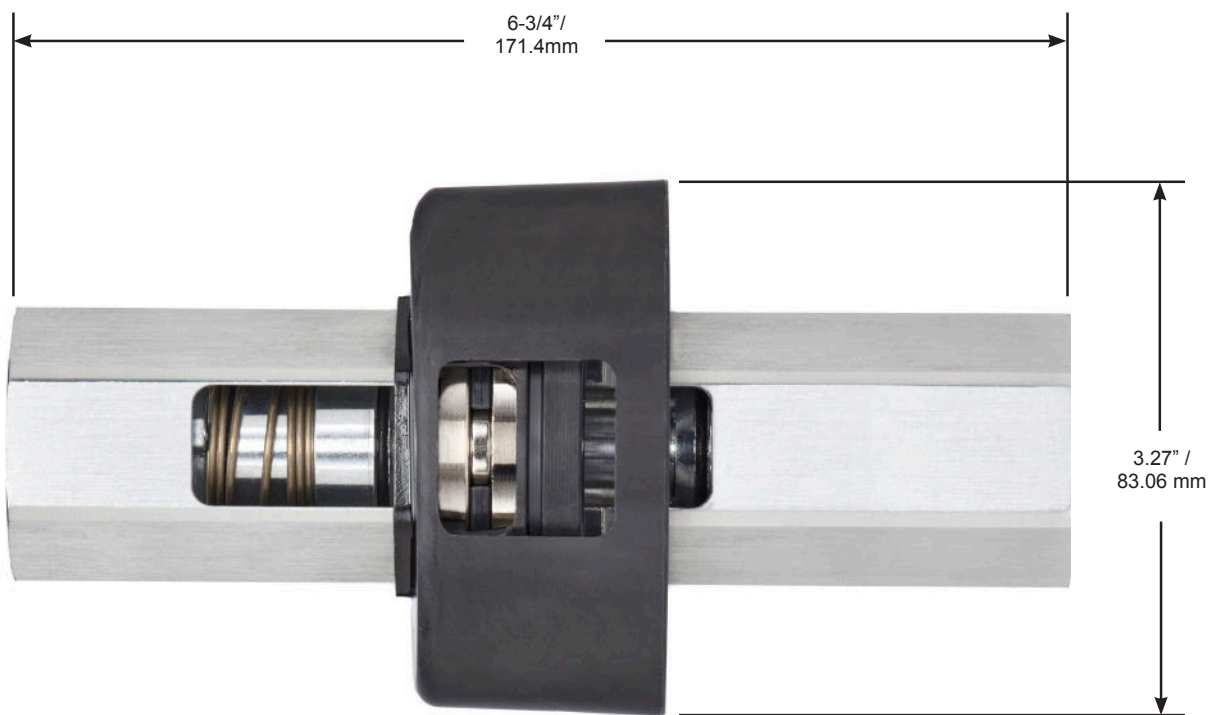

2325 Husky Way • Pacific, MO 63069
 (800) 325-3558 • Fax (636) 825-7300
www.husky.com • sales@husky.com

MADE IN THE U.S.A.