

E25 Safe-T-Breaks®



10-11

SAFE-T-BREAKS®

All Husky® Safe-T-Breaks® stop the flow of fuel on both sides of the separation.

- Compatible with unleaded, diesel and all Ethanol blends through E25.
- Retains the UL listing after being reconnected.
- Unusual interface between a pre-loaded spring and a single turn wave spring that enables valve to resist sudden pressure build-up in the hose resulting in nuisance separations.
- Unit separates at less than 200 lbf / 889.6 N which minimizes “backlash” force of separation, reducing damage to equipment.

E25 Safe-T-Breaks®

MODEL NO.	DESCRIPTION	SHIPPING WEIGHT LBS (KG)
006360	¾" F x ¾" F Reconnectable Safe-T-Break®	.58 (.26)

Construction

Body	Aluminum with Electroless Nickel Plating
Seals	Fluorocarbon and Fluorosilicone
Springs	Stainless Steel Stainless steel load and latch spring reverse mechanism Hardened stainless steel latch ring and ball
Threads	¾" / 19.1 mm NPT

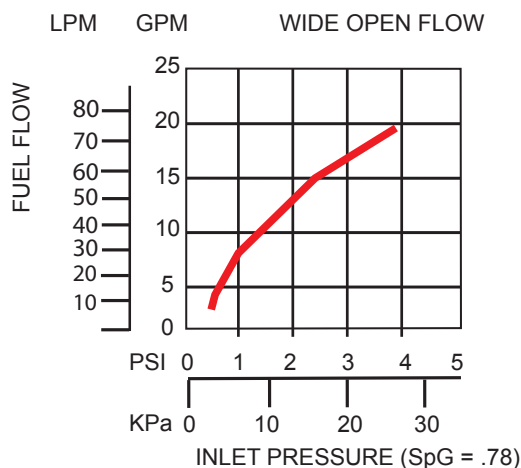

WARNING: Cancer and Reproductive Harm - www.P65Warnings.ca.gov



E25 Safe-T-Breaks®

All Husky® Safe-T-Breaks® stop the flow of fuel on both sides of the separation.

Dimensions and System Options

Guards

MODEL NO.	DESCRIPTION
003097	Black Scuff Guard

Accessories, Testing and Maintenance

MODEL NO.	DESCRIPTION
007000	Safe-T-Break® Drain Cup
003813	Safe-T-Break® Demonstration Kit

Model 006360

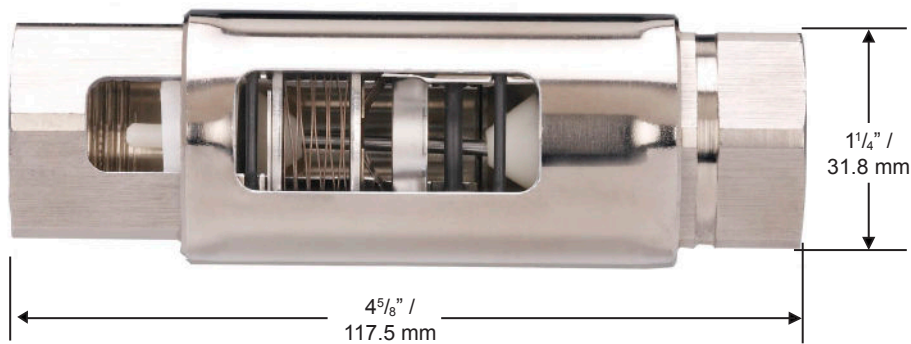

2325 Husky Way • Pacific, MO 63069
 (800) 325-3558 • Fax (636) 825-7300
www.husky.com • sales@husky.com

MADE IN THE U.S.A. 