

# Standard Swivels

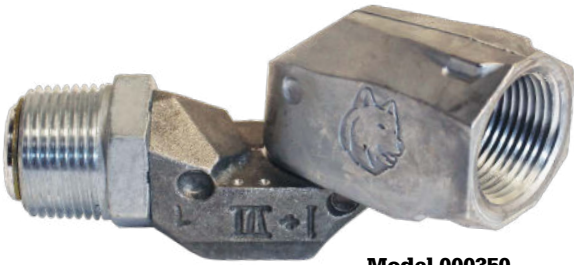

For standard fueling applications.



Model 000350



Model 002272

## Features

### All Husky® Multi-Plane Swivels

- Compatible with unleaded, diesel, and Ethanol blends through E10.
- Compact and light weight for easy handling.
- High flow rates due to laminar flow design.
- High strength step shoulder bearing diameters and impact absorbing stops.

### Model 002950 Restricted Swivel

- Multi-Plane, 210° spherical rotation at the swivel nut.
- Double o-ring seals at each swivel provide long life at low temperatures (-40° F/C).

### All Weather Swivels

- Multi-Plane, full 360° spherical rotation for easy movement of nozzle.
- Double o-ring seals at each swivel provide long life at low temperatures (-40° F/C).

## Construction

Body: High Aluminum Zinc Alloy

Inner O-ring: Fluorsilicone

Outer O-ring: Fluorocarbon

Model No.	Size	Thread	Type	Shipping Wt. Lbs/Kg
000350	3/4" M x 3/4" F	NPT	Multi-Plane Swivel	.50/.22
000352	1" M x 3/4" F	NPT	Multi-Plane Swivel	.66/.29
000355	3/4" M x 3/4" F	NPT	Multi-Plane Swivel, Black	.49/.22
000356	1" M x 3/4" F	NPT	Multi-Plane Swivel, Black	.66/.29
002272	3/4" M x 3/4" F	NPT	90° Swivel	.38/.17
001491	3/4" M x 3/4" F	BSPT	Multi-Plane Swivel	.50/.22
003590	3/4" M x 3/4" F	BSPP	Multi-Plane Swivel	.60/.27
003590A*	3/4" M x 3/4" F	BSPP	Multi-Plane Swivel - ATEX	.60/.27
002771	3/4" M x 3/4" F	BSPP	90° Swivel	.38/.17
002771A*	3/4" M x 3/4" F	BSPP	90° Swivel - ATEX	.38/.17



! WARNING: Cancer and Reproductive Harm - www.P65Warnings.ca.gov

For standard fueling applications.

## Dimensions

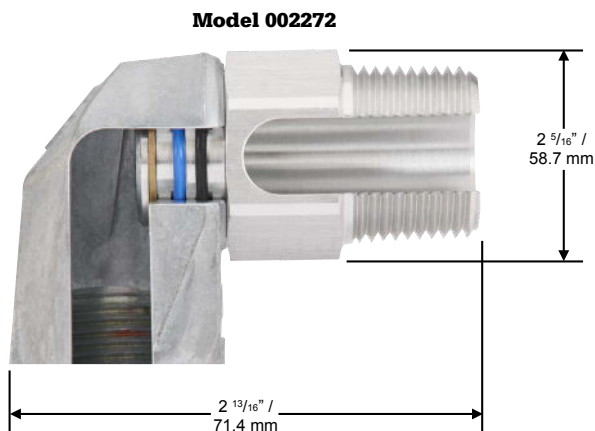
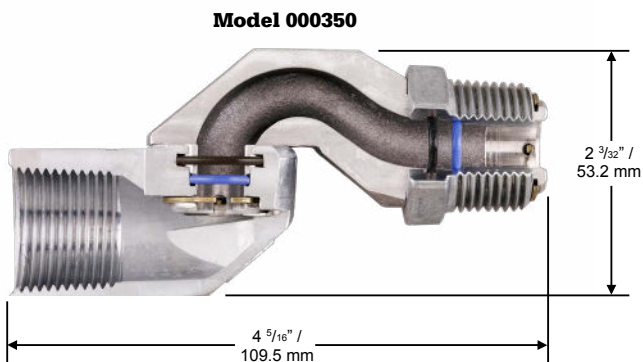

## Flow Charts

