

Vapor Recovery Swivel is compatible with most vacuum assist vapor recovery systems.



Model VR Swivel

Features

- EVR Certified per CARB CP-201.
- 360° rotation at each swivel joint.
- Double o-rings at each swivel joint.
- Can be installed at the nozzle or at the dispenser.
- Stainless steel ball bearings and races allow for easy joint movement and reduces friction, thus extending the life of the swivel.
- Has 2 (two) plane rotation.
- Exceptional flow rate and reduced back pressure.
- Lightweight and compact.

Construction

Body: Zinc

Inlet Body: Aluminum

Swivel Nut: Electroless, Nickel Plated Aluminum or Steel

Seals: Fluorocarbon

Model No.	Size	Thread	Type	Shipping Wt. Lbs/Kg
004605	M34 x 1.5"	M34	Multi-Plane Swivel	1.0 (.45)
004605A*	M34 x 1.5"	M34	Multi-Plane Swivel - Atex	1.0 (.45)
014620	1-1/4"	1-1/4" x 18	Multi-Plane Swivel, 1-1/4"	1.0 (.45)



 WARNING: Cancer and Reproductive Harm - www.P65Warnings.ca.gov

Vapor Recovery Swivel is compatible with most vacuum assist vapor recovery systems.

Dimensions

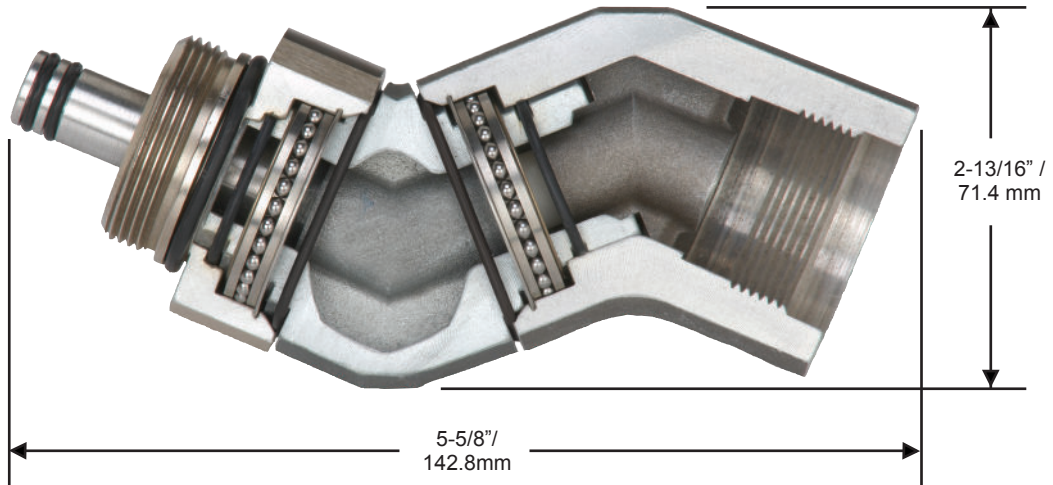

Flow Charts

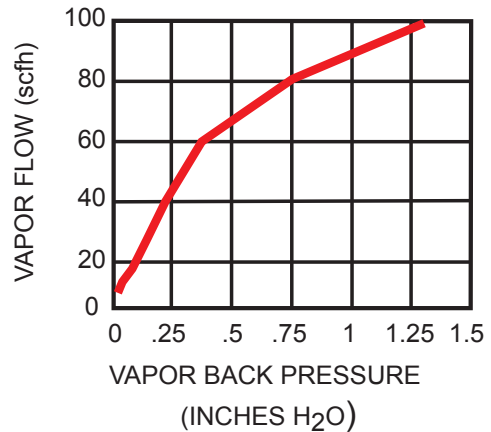
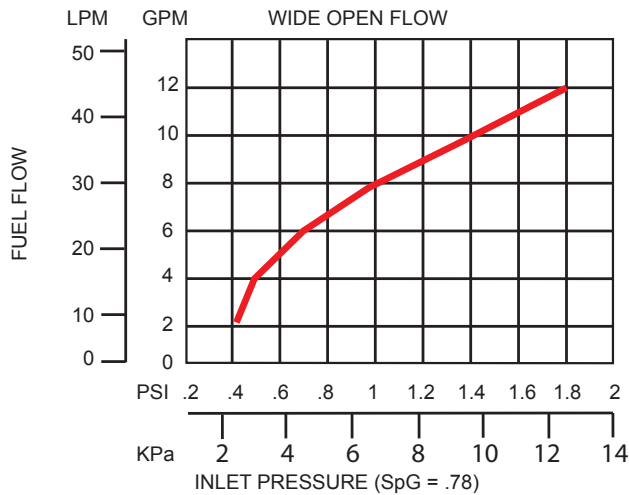

2325 Husky Way • Pacific, MO 63069
 (800) 325-3558 • Fax (636) 825-7300
www.husky.com • sales@husky.com

MADE IN THE U.S.A.