

007 Tank Alarm



High/Low Tank Alarm for use with oil, waste oil, diesel fuel, antifreeze, water and other fluids with a high flash point.

- Avoid costly overflows or untimely shortages.
- Supervised system.
- Low voltage.
- Strobe and siren.
- Can drive up to 10 solenoid valves.
- Easy installation.
- Maximum milliamp load is 750 mA. Do not exceed.

New Gauges and Alarms

MODEL NO.	DESCRIPTION	SHIPPING WEIGHT LBS (KG)
007575	007 Audible and Visual Tank Gauge (includes indoor mount control panel, remote tank sensor, 10' lead wire and 12 volt transformer)	4.0 (1.8)
007555*	007 Audible and Visual Tank Gauge with Jarhead Tank Gauge (includes indoor mount control panel, Jarhead Tank Gauge, and 12 volt transformer) with 2" NPT Tank Fitting	5.0 (2.3)
007560 009963	007 Audible and Visual Tank Gauge with Leak Guard Tank Gauge (includes indoor mount control panel, Leak Guard tank gauge and 12 volt transformer) with 2" NPT Tank Fitting with 1-1/2" NPT Tank Fitting	5.0 (2.3)
007565** 009965**	007 Audible and Visual Tank Gauge with Overfill Tank Gauge (includes indoor mount control panel, Overfill tank gauge and 12 volt transformer) with 2" NPT Tank Fitting with 1-1/2" NPT Tank Fitting	5.0 (2.3)
008295	Audible and Visual Tank Monitor with 12 volt transformer (does not include a tank sensor)	5.0 (2.3)
010304	007 Tank Alarm with built-in 103 Decibel Siren and Strobe Light, Remote 55 Gallon Drum High Level Sensor and 12 volt Transformer	2.8 (1.3)
010305	007 Tank Alarm with built-in 103 Decibel Siren and Strobe Light, Remote 55 Gallon Drum Low Level Sensor with Seal and 12 volt Transformer	3.0 (1.4)
010306	007 Tank Alarm with built-in 103 Decibel Siren and Strobe Light, Remote 55 Gallon Drum High Level Sensor with Seal and 12 volt Transformer	2.8 (1.3)
011875	007 Audible and Visual Tank Gauge, 007 SV Solenoid Valve (includes indoor mount control panel, remote tank sensor, 10' lead wire, pneumatic shut off solenoid valve and two 12 volt transformers)	9.0 (4.1)

*Specify tank depth (in inches) and **riser height (in inches).



WARNING: Cancer and Reproductive Harm - www.P65Warnings.ca.gov



007 Tank Alarm

High/Low Tank Alarm for use with oil, waste oil, diesel fuel, antifreeze, water and other fluids with a high flash point.

Dimensions and System Options

Accessories

MODEL NO.	DESCRIPTION
007595	12 volt Transformer
007660	Remote Tank Sensor
007936*	Remote Jarhead Tank Sensor with 2" tank fitting
008206*	Remote Jarhead Tank Sensor with 1-1/2" tank fitting
007655	Remote Leak Guard Tank Sensor with 2" tank fitting
007656	Remote Leak Guard Tank Sensor with 1-1/2" tank fitting
007742*	Remote Overfill Guard Tank Sensor with 2" tank fitting
007743**	Remote Overfill Guard Tank Sensor with 1-1/2" tank fitting
007695	Strobe Light
007690	Siren - 107 Decibels
007645	Heavy Duty Power Relay - 30 amp or 1-1/2" HP at 120 or 240 vac
009503	Remote 55 Gallon Drum High Level Sensor
009980	Remote 55 Gallon Drum Low Level Sealed Sensor
010000	Remote 55 Gallon Drum High Level Sealed Sensor

*Specify tank depth (in inches) and **riser height (in inches).

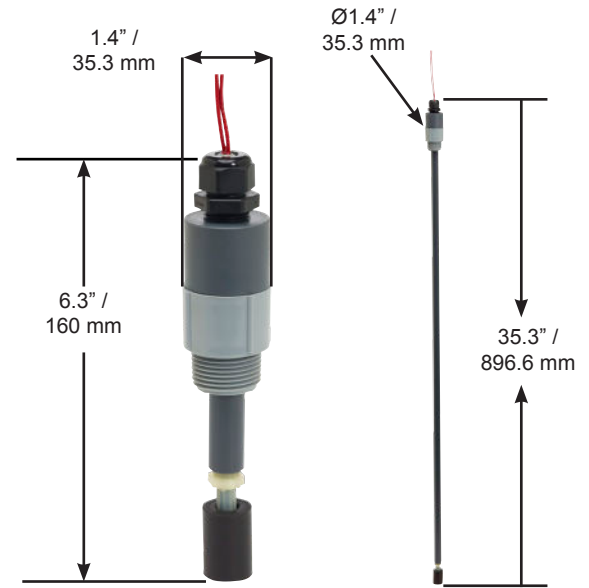

2325 Husky Way • Pacific, MO 63069
 (800) 325-3558 • Fax (636) 825-7300
www.husky.com • sales@husky.com

MADE IN THE U.S.A.