

MK6 Tank Alarm



High/Low Tank Alarm for use with oil, waste oil, diesel fuel, antifreeze, water and other fluids with a high flash point.

- Monitor up to 6 tanks independently.
 - Tank probes sold separately
 - Avoid costly overflows or untimely shortages.
 - Supervised system.
 - Low voltage.
 - Strobe and siren.
 - 6 independent LED displays
- to indicate which circuit is in alarm.
 - Easy installation.
 - Maximum milliamp load is 750 mA.
 - Capable of driving a solenoid valve for each tank monitored.

New Gauges and Alarms

MODEL NO.	DESCRIPTION	SHIPPING WEIGHT LBS (KG)
014509	MK6 Audible and Visual Tank Gauge (includes indoor mount control panel, and 12 volt transformer)	4.0 (1.8)



WARNING: Cancer and Reproductive Harm - www.P65Warnings.ca.gov



MK6 Tank Alarm

High/Low Tank Alarm for use with oil, waste oil, diesel fuel, antifreeze, water and other fluids with a high flash point.

Dimensions and System Options

Accessories

MODEL NO.	DESCRIPTION
007595	12 volt Transformer
007660	Remote Tank Sensor
007936*	Remote Jarhead Tank Sensor with 2" tank fitting
008206*	Remote Jarhead Tank Sensor with 1-1/2" tank fitting
007655	Remote Leak Guard Tank Sensor with 2" tank fitting
007656	Remote Leak Guard Tank Sensor with 1-1/2" tank fitting
007742	Remote Overfill Guard Tank Sensor with 2" tank fitting
007743	Remote Overfill Guard Tank Sensor with 1-1/2" tank fitting
007695	Strobe Light
007690	Siren - 107 Decibels
007645	Heavy Duty Power Relay - 30 amp or 1-1/2" HP at 120 or 240 vac
009503	Remote 55 Gallon Drum High Level Sensor
009980	Remote 55 Gallon Drum Low Level Sealed Sensor
010000	Remote 55 Gallon Drum High Level Sealed Sensor

*Specify tank depth (in inches) and riser height (in inches).

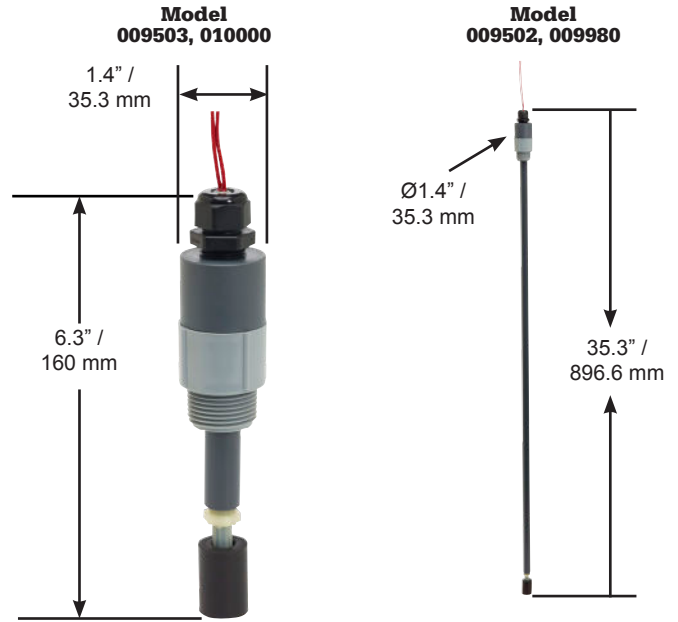

2325 Husky Way • Pacific, MO 63069
 (800) 325-3558 • Fax (636) 825-7300
www.husky.com • sales@husky.com

MADE IN THE U.S.A.