

Sentry Wall Mount



High/Low Tank Alarm for use with oil, waste oil, diesel fuel, antifreeze, water and other fluids with a high flash point.

- Avoid costly overflows or untimely inventory shortages.
- Engineered for most single and double walled aboveground tanks.
- Common 9-volt battery operated or upgradeable to AC power.
- Alarm sounds for up to four days on a fresh battery.
- Ideal for remote areas where AC power is not accessible.
- Simple installation; easy maintenance.



Monitors and Alarms

MODEL NO.	DESCRIPTION	SHIPPING WEIGHT LBS (KG)
007675	Sentry High or Low Wall Mount Battery Operated Tank Alarm with Built-in 103 Decibel Siren and Leak Guard Tank Sensor, with 2" NPT tank fitting	4.8 (2.2)
007676	Sentry High or Low Wall Mount Battery Operated Tank Alarm with Built-in 103 Decibel Siren, Leak Guard Tank Sensor and 12 Volt Transformer, with 2" NPT tank fitting	
007680	Sentry High or Low Wall Mount Battery Operated Tank Alarm with Built-in 103 Decibel Siren and Overfill Tank Sensor, with 2" NPT tank fitting	4.0 (1.8)
007681	Sentry High or Low Wall Mount Battery Operated Tank Alarm with Built-in 103 Decibel Siren, Overfill Tank Sensor, and 12 Volt Transformer, with 2" NPT tank fitting	5.5 (2.5)
007725	Sentry High or Low Wall Mount Battery Operated Tank Alarm with Built-in 103 Decibel Siren, with 2" NPT tank fitting	3.0 (1.4)
007726	Sentry High or Low Wall Mount Battery Operated Tank Alarm with Built-in 103 Decibel Siren and 12 Volt Transformer, with 2" NPT tank fitting	
007685*	Sentry High or Low Wall Mount Battery Operated Tank Alarm with Built-in 103 Decibel Siren and Jarhead Tank Sensor, with 2" NPT tank fitting	5.5 (2.5)
007686* 009972	Sentry High or Low Wall Mount Battery Operated Tank Alarm with Built-in 103 Decibel Siren, Jarhead Tank Sensor, and 12 Volt Transformer, with 2" NPT tank fitting with 1-1/2" NPT tank fitting	6.5 (3.0)
010713	Sentry Wall Mount Tank Alarm with Built-in 103 Decibel Siren, Remote 55 Gallon Drum High Level Sensor and Battery	3.0 (1.4)

*Specify tank depth (in inches) and **riser height (in inches)



WARNING: Cancer and Reproductive Harm - www.P65Warnings.ca.gov



Sentry Wall Mount

High/Low Tank Alarm for use with oil, waste oil, diesel fuel, antifreeze, water and other fluids with a high flash point.

Dimensions and System Options

Sensors

MODEL NO.	DESCRIPTION
007661	Remote Tank Sensor
007650	Remote Jarhead Tank Sensor - 2" Tank Fitting
008211	Remote Jarhead Tank Sensor - 1 1/2" Tank Fitting
007657	Remote Leak Guard Tank Sensor - 2" Tank Fitting
007658	Remote Leak Guard Tank Sensor - 1 1/2" Tank Fitting
007740	Remote Overfill Guard Tank Sensor - 2" Tank Fitting
007741	Remote Overfill Guard Tank Sensor - 1 1/2" Tank Fitting
010821	Remote 55 Gallon Drum Low Level Sensor
010824	Remote 55 Gallon Drum High Level Sealed Sensor

Accessories

MODEL NO.	DESCRIPTION
007829	Adaptor, 1-1/2" NPT
007689	Adaptor, 2" NPT
007551	Chain, #2 Ball
007552	Eyelet, Brass
007606	Float Sensor
007692	Jar, Jarhead
007865	Jar, Leak
007866	Jar, Overfill

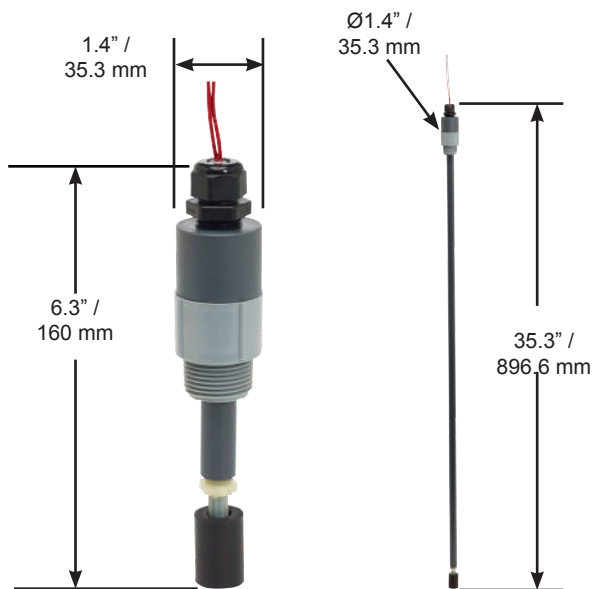
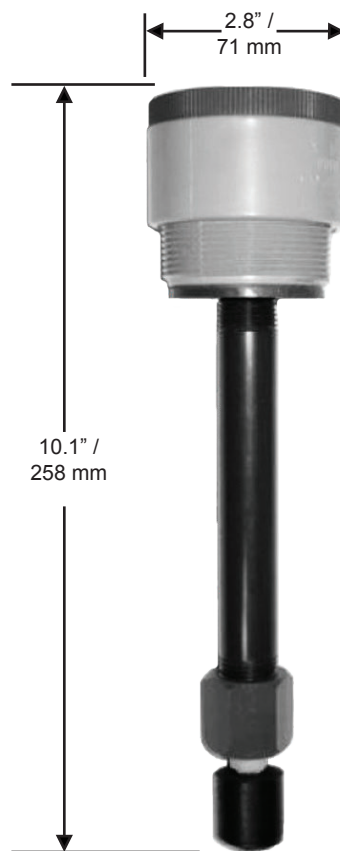
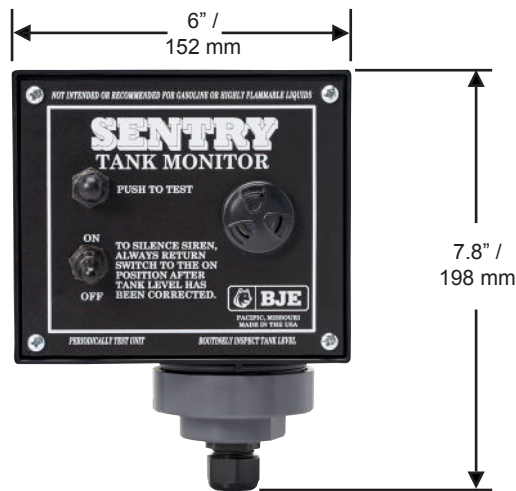

2325 Husky Way • Pacific, MO 63069
 (800) 325-3558 • Fax (636) 825-7300
www.husky.com • sales@husky.com

MADE IN THE U.S.A.