

# Kaltey Commander Tank Controller Wall Mount



**Tank Controller for use with oil, waste oil, diesel fuel, antifreeze, water and other fluids with a high flash point.**

- Self-regulating fluid transfer system.
- Provides automatic re-filling of monitored tank.
- Prevents costly tank overfills.
- Built in overfill monitoring-103 decibel alarm siren and flashing LED.
- Push to fill button provides instant topping off of monitored tank.
- Engineered for most single or double wall tanks with 2" NPT bung opening.
- Designed for tank depths between 24"-78" (610 mm-1981 mm).
- Requires one air powered diaphragm pump not included.
- System shuts off air to diaphragm pump and oil flow to day tank when high level sensor is tripped.
- System includes: wall mounted controller, air solenoid valve, fluid control valve, 115 volt ac adaptor, 25 ft of cabling.
- Tank depth and riser height information required at time of order.

### Monitors and Alarms

MODEL NO.	DESCRIPTION	SHIPPING WEIGHT LBS (KG)
010614	Kaltey Commander Wall Mount Tank Controller	14 (6.4)



**WARNING:** Cancer and Reproductive Harm—[www.P65Warnings.ca.gov](http://www.P65Warnings.ca.gov)



# Kaltey Commander Tank Controller Wall Mount

Tank Controller for use with oil, waste oil, diesel fuel, antifreeze, water and other fluids with a high flash point.

## Dimensions and System Options

### Accessories

MODEL NO.	DESCRIPTION
013752	Kaltey Commander Wall Mount Tank Controller Remote Sensor

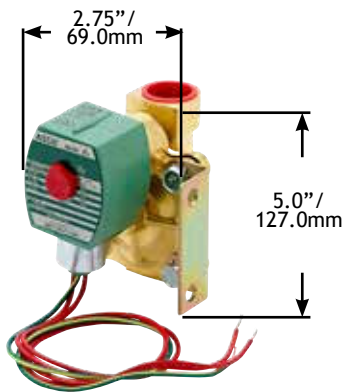
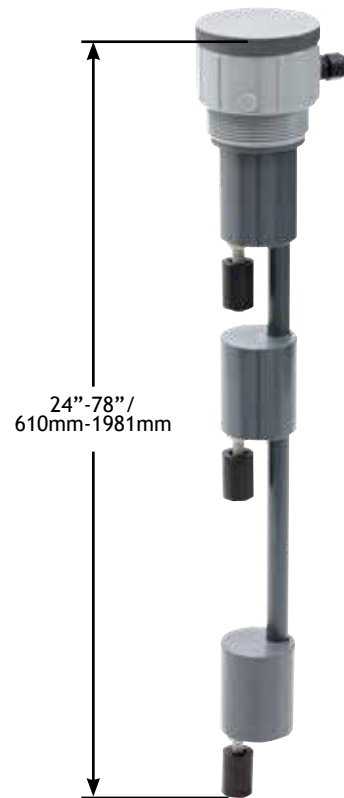

2325 Husky Way • Pacific, MO 63069  
 (800) 325-3558 • Fax (636) 825-7300  
[www.husky.com](http://www.husky.com) • [sales@husky.com](mailto:sales@husky.com)

MADE IN THE U.S.A.