

PRODUCT CATALOG



Contents

Husky Catalog	7
Conventional Nozzles	9
XS® Nozzles	11
XS® MFM Nozzles	15
X Nozzles	19
1A Nozzles	23
1AS Nozzles	27
ECO Nozzles	31
Truck & High Volume Nozzles	35
VIII S Nozzles	37
VIII S Nozzles	39
VIII Nozzles	41
1HS Nozzles	45
1HSS Nozzles	49
1690/1691 Nozzles	53
Farm & Commercial Nozzles	57
XFS® Nozzles	59
1GS Nozzles	63
1GSS Nozzles	67
Diesel Exhaust Fluid Nozzles	71
SST DEF Nozzles	73
POLY DEF Nozzles	77
X DEF Nozzles	81
Conventional Ethanol Fueling Nozzles	85
XS® E25 Nozzles	87
X E85 Nozzles	91
XS® E85 Nozzles	95
Vapor Recovery Nozzles	99
V34 Nozzles	101
V34 COAX Nozzles	105
V34 ORVR Nozzles	109
V34iS Nozzles	113

Contents

Distilled Spirits Dispensing	117
SST WN Nozzles	119
X WN Nozzles	123
1A WN Nozzles	127
VIII WN Nozzles	131
1690 WN Nozzles	135
Swivels	139
Standard Swivels	141
Inline Swivels	143
F&C Standard Swivels	145
F&C High Volume Swivels	147
Vapor Recovery Swivels	149
High Volume Swivels	151
Ultra High Flow Swivels	153
DEF Swivels	155
E85 Swivel	157
Safe-T-Breaks®	159
Standard STB	161
MAG MAGBREAK®	163
F&C Standard STB	165
F&C High Volume STB	167
DEF Safe-T-Break®	169
High Volume STB	171
Balance Vapor STB	173
Vacuum Assist STB	175
E85 Safe-T-Breaks®	177
VAC Assist MAGBREAK®	179
E25 Safe-T-Breaks®	181
Inline STB	183
E25/E85 MAGBREAK®	185
Swivels/STB Combos	187
Standard Swivel/STB	189
High Volume Swivel/STB	191
Inline Combo Swivel/STB	193

Contents

Guards	195
Husky® Guards	197
POPD Guards	199
Spouts	201
X, XS® Spouts	203
1GS Spouts	205
DEF Spouts	207
VIII, VIIS Spouts	209
V3 & V34 Spouts	211
E85 Spouts	213
PV Vents	215
PV Vents	217
Testing & Maintenance	221
Nozzle Service Kit	223
HCA Hose Conversion Adaptor	225
Mobile Fill Neck Device	227
Full Filter & Drain Cups	229
Flo-Equalizers®	231
Flo-Equalizer®	233
DEF Adaptors	235
DEF Adaptors	237
Hoses	239
EagleFlex® Hardwall	241
EagleFlex® Softwall	243
EagleFlex® Wirebraid	245
EagleFlex® Farm Tank	247
Whip Hoses	249
DEF Dispensing	251
EagleFlex® Low Perm Hardwall	253
Whip Low Perm Hoses	255
Fuel Oil Hose	257
EagleFlex® E0-E85	259

Contents

EZ-Connect®	261
EZ-Connect®	263
BJE Catalog	265
Crushers	267
C-4 Crusher	269
C-6 Crusher	271
TT-12 Crusher	273
TT-25 Crusher	275
Filter Crusher Stands	277
Tank Gauges	279
Black Knight® LLG	281
Metric Black Knight®	283
Red Fox® LLG	285
Metric Red Fox®	287
Jarhead Tank Gauge	289
JAR Adjustable Jarhead	291
Overfill Tank Gauge	293
Leak Guard Tank Gauge	295
Seasee Drum Gauge	297
DEF Black Knight® LLG	299
Clearly Gauge® LLG	301
Tank Gauges and Alarms	305
007 Tank Alarm	307
Sentry Tank Alarm	309
Sentry Wall Mount	311
DEF Jarhead	313
DEF Overfill Guard	315
DEF 007 Jarhead Tank Alarm	317
DEF 007 Overfill Tank Alarm	319
DEF Sentry Jarhead Alarm	321
DEF Sentry Overfill Alarm	323
55 Drum Alert	325
55 Drum Alarm	327

Contents

FNTM Drum Gauge	329
Kaltey Commander	331
Kaltey Commander	333
MK6 Tank Alarm	335
Gauge Accessories	337
AD 110 Drain Valve	339
Solenoid Valve System	341
Solenoid Valves	343
Siren/Sensor/Strobe	345
TM3 Valve	347
Hewitt Catalog	349
Aviation Hoses	351
4113 Permanent	353
4113 Reusable	355
5500 JacRiser	359
Deadman Hose	
Twin 1/4-Inch	361
Twin 3/8-Inch	363
Aviation Nozzles	365
Osprey Nozzle	367
Falcon Manual Nozzle	369
Falcon Manual Nozzle	371
Parts & Accessories	373
Aviation Couplings	375
Spiral Hose Protectors	376
Aviation Swivels	377
Falcon Spouts	379
Aviation NPT Strainer	381
Roman Seliger Catalog	383
Loading Arms	385
SGA Loading Arm	387



GENERAL FUELING PRODUCTS

Husky Catalog



Conventional Nozzles

Pressure-activated, automatic shut-off nozzle for full-service and self-service stations.

- XS[®] nozzle shuts off when:
 - the pump shuts off
 - the gas tank is full
 - the lever is opened before the pump is turned on
 - the leak detector has not completed the test cycle
- Stainless steel reinforced spout bushing keeps spout tip round, and acts as a captive fastener to prevent tip-end sensor damage.
- Nozzle is equipped with a unique Flo-Stop[®] device that shuts off the nozzle if it falls from the fill neck or raises above the horizontal.
- *StreamShaper*[®] reduces turbulence for straighter fuel flow and less splash back spillage.
- Comes standard with smooth full grip guard
- Tilt poppet design provides precise “to-the-penny” dispensing.
- Optional sightglass provides a clear window for the customer to view the fuel as it passes through the main poppet valve.
- Optional cold weather seals are rated to -40° F/C
- Optional Gilbarco, Tokheim, and Wayne handguards can be fitted with a magnet to trigger the dispenser’s proximity switch, or can be provided without the magnet for dispensers equipped with a standard “flapper” switch.
- Optional Flo-Equalizer[®] prohibits the nozzle from exceeding 10 gpm (37.9 Lpm).
- Optional Drip Less spout mitigates the amount of fuel released from the spout tip after refueling is completed.
- ADA-compliant EZ Lever reduces the force required to open the main poppet valve by 50%, resulting in a lever operating force ≤5 lbs.



MODEL NO.
159504

New Unleaded Nozzles with NPT Inlet

MODEL NO.	DESCRIPTION	SHIPPING WEIGHT LBS (KG)
159504	with Two Notch Hold Open Clip	3.0 (1.4)
159508	without Hold Open Clip	3.0 (1.4)
159543	with Single Notch Hold Open Clip, 1808 Waffle Splash Guard and Flo-Equalizer [®]	3.2 (1.5)
159544	with Two Notch Hold Open Clip, 1808 Waffle Splash Guard and Flo-Equalizer [®]	3.2 (1.5)
159554	with Two Notch Hold Open Clip and Flo-Equalizer [®]	3.1 (1.4)
159554N	with Two Notch Hold Open Clip and Flo-Equalizer [®]	3.1 (1.4)
159559	with Two Notch Hold Open Clip and 1808 Waffle Splash Guard	3.1 (1.4)
159566	without Hold Open Clip, with 1808 Waffle Splash Guard	3.0 (1.4)
159576	with Two Notch Hold Open Clip and 1807 Waffle Splash Guard	3.1 (1.4)
159582	with Two Notch Hold Open Clip and Drip Less Spout	3.0 (1.4)
159595	with Two Notch Hold Open Clip, POPD [®] S and 1808 Waffle Splash Guard	3.2 (1.5)
498104	with Two Notch Hold Open Clip and Cold Weather Seals	3.0 (1.4)
498108	without Hold Open Clip, with Cold Weather Seals	3.0 (1.4)
E498159	with Two Notch Hold Open Clip, Mate Guard, Polymer Handle Cover, 1808 Waffle Splash Guard and Cold Weather Seals	3.1 (1.4)
498166	without Hold Open Clip, with 1808 Waffle Splash Guard and Cold Weather Seals	3.0 (1.4)
159504N [^]	with Two Notch Hold Open Clip	3.0 (1.4)
E159504	with Two Notch Hold Open Clip, Mate Guard and Polymer Handle Cover	3.0 (1.4)
E159504N [^]	with Two Notch Hold Open Clip, Mate Guard and Polymer Handle Cover	3.0 (1.4)
1595108	without Hold Open Clip, with POPD [®] S and 1808 Waffle Splash Guard	3.1 (1.4)
1595126	without Hold Open Clip, with POPD [®] S	3.1 (1.4)
1595146	with Two Notch Hold Open Clip, POPD [®] H and 1808 Waffle Splash Guard	3.1 (1.4)
1595179	with Single Notch Hold Open Clip and 1808 Waffle Splash Guard	3.1 (1.4)
1595214N	with Two Notch Hold Open Clip, 1” Longer Spout and Barbed Vent Tube Fitting	3.1 (1.4)
E159559	with Two Notch Hold Open Clip, 1808 Waffle Splash Guard, Mate Guard and Polymer Handle Cover	3.1 (1.4)
E1302704N [^]	with Two Notch Hold Open Clip, Mate Guard, Polymer Handle Cover, and Gradual Pressure Relief	3.0 (1.4)
E1595287	with Two Notch Hold Open Clip, Mate Guard, Polymer Handle Cover, 1807 Waffle Splash Guard	3.1 (1.4)

[^] NOT LISTED

New Unleaded Nozzles with BSP Inlet

MODEL NO.	DESCRIPTION	SHIPPING WEIGHT LBS (KG)
E159516N	with Two Notch Hold Open Clip, Mate Guard and Polymer Handle Cover	3.0 (1.4)
E1523016N	with Two Notch Hold Open Clip, Mate Guard, Polymer Handle Cover, and Wayne Magnetic Handguard	3.3 (1.5)
E1595245	with Two Notch Hold Open Clip, Mate Guard, Polymer Handle Cover, 1808 Waffle Splash Guard and Drip Less Spout	3.1 (1.4)
E1595286	with Hold Open Clip, Mate Guard, Polymer Handle Cover, 1807 Waffle Splash Guard	3.1 (1.4)

[^] NOT LISTED



II 1 G
EN 13012
TYPE 1



WARNING: Cancer and Reproductive Harm - www.P65Warnings.ca.gov

XS[®] Nozzles

Pressure-activated, automatic shut-off nozzle for full-service and self-service stations.

Dimensions

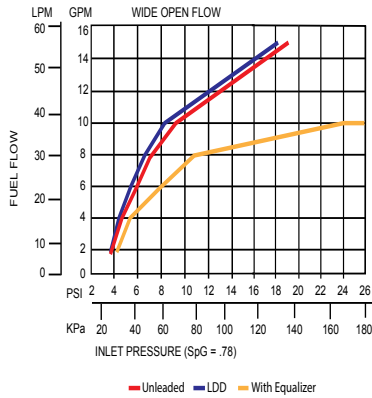
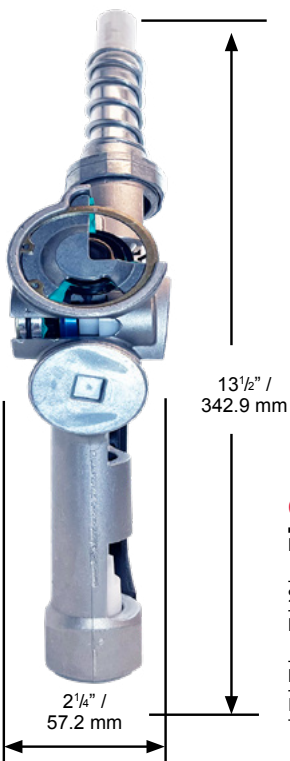
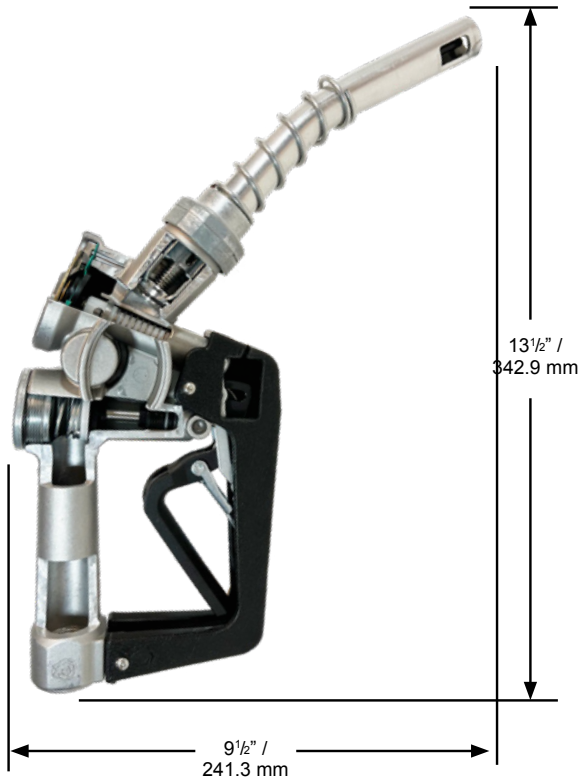

Construction

Body	One piece die cast aluminum with high-impact polymer handguard
Seals	Fluorocarbon
Packing	Double o-ring seal protected by fiber-reinforced Teflon [®]
Lever	Two Piece Polymer EZ Lever
Inlet	3/4" (19 mm) NPT or 3/4" (19 mm) BSP

New Light Duty Diesel Nozzles with NPT Inlet

MODEL NO.	DESCRIPTION	SHIPPING WEIGHT LBS (KG)
159503	with Two Notch Hold Open Clip	3.0 (1.4)
159507	without Hold Open Clip	3.0 (1.4)
159545	with Two Notch Hold Open Clip, 1808 Waffle Splash Guard and Flo-Equalizer [®]	3.2 (1.5)
159553	with Two Notch Hold Open Clip and Flo-Equalizer [®]	3.1 (1.4)
159561	with Two Notch Hold Open Clip and 1808 Waffle Splash Guard	3.1 (1.4)
159567	without Hold Open Clip, with 1808 Waffle Splash Guard	3.0 (1.4)
159578	with Two Notch Hold Open Clip and 1807 Waffle Splash Guard	3.1 (1.4)
159596	with Two Notch Hold Open Clip, POP D [®] S and 1808 Waffle Splash Guard	3.2 (1.5)
159597	with Single Notch Hold Open Clip and 1808 Waffle Splash Guard	3.1 (1.4)
498103	with Two Notch Hold Open Clip and Cold Weather Seals	3.0 (1.4)
498161	with Two Notch Hold Open Clip, 1808 Waffle Splash Guard and Cold Weather Seals	3.1 (1.4)
498167	without Hold Open Clip, with 1808 Waffle Splash Guard and Cold Weather Seals	3.0 (1.4)
1595171	with Single Notch Hold Open Clip, 1808 Waffle Splash Guard and Flo-Equalizer [®]	3.2 (1.5)
1595211	with Two Notch Hold Open Clip, 1808 Waffle Splash Guard and Drip Less Spout	3.1 (1.4)
159503N [^]	with Two Notch Hold Open Clip	3.0 (1.4)
E159503	with Two Notch Hold Open Clip, Mate Guard and Polymer Handle Cover	3.0 (1.4)
E159507	without Hold Open Clip, with Mate Guard and Polymer Handle Cover	3.0 (1.4)
E159561	with Two Notch Hold Open Clip, 1808 Waffle Splash Guard, Mate Guard and Polymer Handle Cover	3.1 (1.4)
E1595133N [^]	with Two Notch Hold Open Clip, Mate Guard, Polymer Handle Cover, and Gradual Pressure Relief	3.0 (1.4)
E159508	without Hold Open Clip with Mate Guard	3.0 (1.4)
E159567	without Hold Open Clip, Mate Guard with 1808 Waffle Splash Guard	3.2 (1.5)
E159596	with Two Notch Hold Open Clip, POPD [®] S, Mate Guard and 1808 Waffle Splash Guard	3.2 (1.5)
E498103	with Two Notch Hold Open Clip with Mate Guard and Cold Weather Seals	3.2 (1.5)
E1595211	with Hold Open Clip, Mate Guard, Polymer Handle Cover, 1808 Waffle Splash Guard, Drip Less Spout	3.1 (1.4)
E1595247	without Hold Open Clip, with Mate Guard, Polymer Handle Cover, 1808 Waffle Splash Guard and Drip Less Spout	3.1 (1.4)
E1595288	with Hold Open Clip, Mate Guard, Polymer Handle Cover, 1807 Waffle Splash Guard	3.1 (1.4)
1690803N [^]	with Two Notch Hold Open Clip, 1808 Waffle Splash Guard and Cold Weather Seals	3.0 (1.4)

[^] NOT LISTED

New Light Duty Diesel Nozzles with BSP Inlet

MODEL NO.	DESCRIPTION	SHIPPING WEIGHT LBS (KG)
E1595107	with Hold Open Clip, Mate Guard, Polymer Handle Cover, 1807 Waffle Splash Guard	3.1 (1.4)
E1595244	with Two Notch Hold Open Clip, Mate Guard, Polymer Handle Cover, 1808 Waffle Splash Guard and Drip Less Spout	3.1 (1.4)

[^] NOT LISTED

Pressure-activated, automatic shut-off nozzle for full-service and self-service stations.

Nozzle Options

Nozzle Guard Options



Full Grip Guard

POPD[®]S
Full Grip Guard

POPD[®]H
Full Grip Guard

Mate Guard

POPD[®]S
Mate Guard

POPD[®]H
Mate Guard

Waffle Guard Options



1807 Waffle Guard



1808 Waffle Guard

Handguard Options



Standard Polymer
Handguard

Gilbarco Polymer
Handguard
(with or without Magnet)

Tokheim Polymer
Handguard
(with or without Magnet)

Wayne Polymer
Handguard
(with or without Magnet)

Latch Plate Options

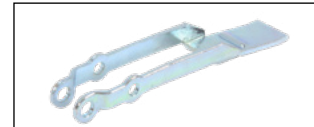

1 - Position Latch Plate



2 - Position Latch Plate

Lever Options



Lever without Hold
Open Clip



Lever with Hold
Open Clip

Flo-Equalizer[®] Option

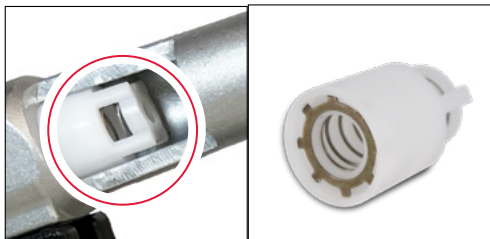

Sightglass Option



XS[®] Nozzles

Pressure-activated, automatic shut-off nozzle for full-service and self-service stations.

System Options

Safe-T-Breaks[®]

MODEL NO.	DESCRIPTION
002273	3/4" F x 3/4" F NPT Non-Reconnectable Safe-T-Break [®]
002774	3/4" F x 3/4" F BSPP Non-Reconnectable Safe-T-Break [®]
003360	3/4" F x 3/4" F NPT Reconnectable Safe-T-Break [®]
003385	3/4" F x 3/4" F BSPP Reconnectable Safe-T-Break [®]
005230	3/4" F x 3/4" F NPT Low Pull Reconnectable Safe-T-Break [®]
006130	3/4" F x 3/4" F NPT Non-Reconnectable PCC Safe-T-Break [®]
008330	3/4" F x 3/4" F NPT Reconnectable MAGBREAK [®]
009910	3/4" F x 3/4" F BSPP Reconnectable MAGBREAK [®]
010328	3/4" F x 3/4" F NPT Reconnectable High Pull MAGBREAK [®]
010330	3/4" F x 3/4" F BSPP Reconnectable High Pull MAGBREAK [®]
002774A	3/4" F x 3/4" F BSPP Non-Reconnectable Safe-T-Break [®] - Atex
003385A	3/4" F x 3/4" F BSPP Reconnectable Safe-T-Break [®] - Atex

Swivel/Safe-T-Break[®] Combos

MODEL NO.	DESCRIPTION
006310	3/4" M NPT Multi-Plane Swivel connected to 3/4" F NPT Reconnectable Safe-T-Break [®]
007085	3/4" M BSPP Multi-Plane Swivel connected to 3/4" F BSPP Reconnectable Safe-T-Break [®]
007085A	3/4" M BSPP Multi-Plane Swivel connected to 3/4" F BSPP Reconnectable Safe-T-Break [®] - Atex

Spouts

MODEL NO.	DESCRIPTION
001471	Light Duty Diesel Spout
001473	Unleaded Spout
010353	Light Duty Diesel Long Spout
010434	Unleaded Long Spout

Pressure/Vacuum Vents

MODEL NO.	DESCRIPTION
004620	2" Slip-On Pressure Vacuum Vent
004885	2" Thread-On Pressure Vacuum Vent - NPT
005885	2" Thread-On Pressure Vacuum Vent with Internal Screen - NPT

Accessories, Testing and Maintenance

MODEL NO.	DESCRIPTION
000397	Unleaded Spout Gauge
003593	Hold Open Clip Kit
004490	Conventional Flo-Equalizer [®] - 10 gpm / 37.9 Lpm
007089	Nozzle Service Kit
007490	Internal Flo-Equalizer [®] - 10 gpm / 37.9 Lpm

Swivels

MODEL NO.	DESCRIPTION
000350	3/4" M x 3/4" F NPT Multi-Plane Swivel
000355	3/4" M x 3/4" F NPT Multi-Plane Swivel Anodized Black
002272	3/4" M x 3/4" F NPT 90° Pump Swivel
002771	3/4" M x 3/4" F BSPP 90° Pump Swivel
002950	3/4" M x 3/4" F NPT Multi-Plane Restricted Swivel
003590	3/4" M x 3/4" F BSPP Multi-Plane Swivel
003895	3/4" M x 3/4" F NPT Inline Swivel
002771A	3/4" M x 3/4" F BSPP 90° Pump Swivel - Atex
003590A	3/4" M x 3/4" F BSPP Multi-Plane Swivel - Atex

Guards

MODEL NO.	DESCRIPTION
001506	Protection Package
001806	Full Grip Reguard
001807	Waffle Splash Guard with Small Hole
001808	Waffle Splash Guard
001809	Reguard Protection Package
003440	Mate Easy-On Package
003795	Mate Guard
004145	Full Grip Guard
006628	POPD [®] S Clear Cover
006665	POPD [®] S Full Grip Guard
007205	POPD [®] S Full Grip Reguard
007361	Black Handle Cover
007999	POPD [®] H Clear Cover
008165	POPD [®] S Mate Guard
008166	POPD [®] H Mate Guard
008175	POPD [®] EZS Nozzle Guard
008176	POPD [®] EZH Nozzle Guard
008185	POPD [®] H Full Grip Guard
008192	POPD [®] H Full Grip Reguard
014524	International Mate Package
014530	International Mate Guard
015247	International POPD [®] H Mate Guard
015253	International POPD [®] H Mate Package

Guard Color Chart

COLOR	SUFFIX	COLOR	SUFFIX	COLOR <i>CUSTOM</i>	SUFFIX
Blue	-01	Gold	-08	Amoco Blue	-07 <i>CUSTOM</i>
Red	-02	Silver	-09	Apple Green	-18 <i>CUSTOM</i>
Green	-03	BP Green	-16	Purple	-19 <i>CUSTOM</i>
Black	-04	M Blue	-21	Pink	-20 <i>CUSTOM</i>
Yellow	-05	Orange	-39	BPS Green	-22 <i>CUSTOM</i>
White	-06				

Scuff Guards are to be ordered with the corresponding guard color option added to the model number. Example: If BLUE guards are desired, add guard color option -01 to the model number (159504-01). For custom colors, a minimum order of 4,000 guards will be required.

XS[®] MFM Nozzles

Pressure-activated, automatic shut-off nozzle for full-service and self-service stations.

- XS[®] MFM nozzle shuts off when:
 - the pump shuts off
 - the gas tank is full
 - the lever is opened before the pump is turned on
 - the leak detector has not completed the test cycle
- Stainless steel reinforced spout bushing keeps spout tip round, and acts as a captive fastener to prevent tip-end sensor damage.
- Nozzle is equipped with a unique Flo-Stop[®] device that shuts off the nozzle if it falls from the fill neck or raises above the horizontal.
- *StreamShaper*[®] reduces turbulence for straighter fuel flow and less splash back spillage.
- Comes standard with smooth full grip guard
- Tilt poppet design provides precise “to-the-penny” dispensing.
- Optional sightglass provides a clear window for the customer to view the fuel as it passes through the main poppet valve.
- Optional cold weather seals are rated to -40° F/C.
- Optional Gilbarco, Tokheim, and Wayne handguards can be fitted with a magnet to trigger the dispenser’s proximity switch, or can be provided without the magnet for dispensers equipped with a standard “flapper” switch.
- Optional Flo-Equalizer[®] prohibits the nozzle from exceeding 10 gpm (37.9 Lpm).
- Optional Drip Less spout mitigates the amount of fuel released from the spout tip after refueling is completed.
- ADA-compliant EZ Lever reduces the force required to open the main poppet valve by 50%, resulting in a lever operating force ≤5 lbs.



MODEL NO.
159562

New Unleaded Nozzles with NPT Inlet

MODEL NO.	DESCRIPTION	SHIPPING WEIGHT LBS (KG)
159562	with Two Notch Hold Open Clip and 1808 Waffle Splash Guard	3.3 (1.5)
498162	with Two Notch Hold Open Clip, 1808 Waffle Splash Guard and Cold Weather Seals	3.3 (1.5)

^ NOT LISTED

New Light Duty Diesel Nozzles with NPT Inlet

MODEL NO.	DESCRIPTION	SHIPPING WEIGHT LBS (KG)
159560	with Two Notch Hold Open Clip and 1808 Waffle Splash Guard	3.3 (1.5)
1595267	with Two Notch Hold Open Clip, 1808 Waffle Splash Guard and Drip Less Spout	3.3(1.5)
E159560	with Two Notch Hold Open Clip, Mate Guard, Polymer Handle Cover and 1808 Waffle Splash Guard	3.3(1.5)

^ NOT LISTED

New Unleaded Nozzles with M34 Inlet

MODEL NO.	DESCRIPTION	SHIPPING WEIGHT LBS (KG)
E1595293N [^]	with Two Notch Hold Open Clip, Mate Guard, Polymer Handle Cover and 1808 Waffle Splash Guard	3.3(1.5)
E15230293N [^]	with Two Notch Hold Open Clip, Wayne Magnetic Handguard, Mate Guard, Polymer Handle Cover and 1808 Waffle Splash Guard	3.3(1.5)
E15230298N [^]	with Two Notch Hold Open Clip, Wayne Magnetic Handguard, Mate Guard and Polymer Handle Cover	3.3(1.5)

^ NOT LISTED

New Light Duty Diesel Nozzles with M34 Inlet

MODEL NO.	DESCRIPTION	SHIPPING WEIGHT LBS (KG)
E1525297N [^]	with Two Notch Hold Open Clip, Mate Guard, Polymer Handle Cover and 1808 Waffle Splash Guard	3.3(1.5)
E15230297 [^]	with Two Notch Hold Open Clip, Wayne Magnetic Handguard, Mate Guard and Polymer Handle Cover	3.3(1.5)

^ NOT LISTED



II 1 G
EN 13012
TYPE 1



P-TÜ7-8113626964

WARNING: Cancer and Reproductive Harm - www.P65Warnings.ca.gov

XS[®] MFM Nozzles

Pressure-activated, automatic shut-off nozzle for full-service and self-service stations.

Dimensions

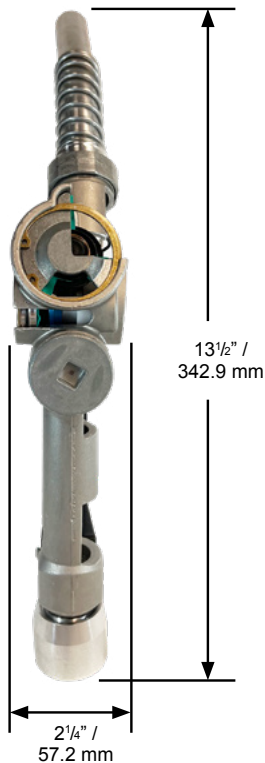

Construction

Body	Die cast aluminum body with high-impact polymer handguard and permanently-secured, machined aluminum inlet adapter
Seals	Fluorocarbon
Packing	Double o-ring seal protected by fiber-reinforced Teflon®
Lever	Two piece polymer EZ Lever
Inlet	1" (25.4 mm) NPT, 1" (25.4 mm) BSP or M34

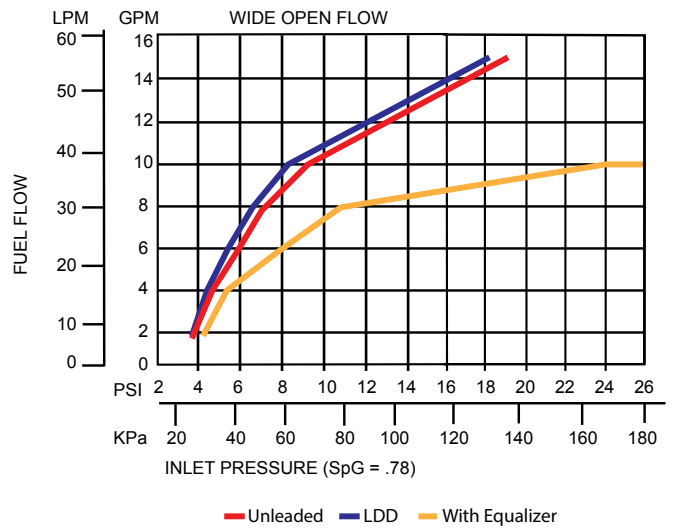

XS[®] MFM Nozzles

CONVENTIONAL FUELLING

Pressure-activated, automatic shut-off nozzle for full-service and self-service stations.

Nozzle Options

Nozzle Guard Options



Full Grip Guard

POPD[®]S Full Grip Guard

POPD[®]H Full Grip Guard

Mate Guard

POPD[®]S Mate Guard

POPD[®]H Mate Guard

Waffle Guard Options



1807 Waffle Guard



1808 Waffle Guard

Handguard Options



Standard Polymer Handguard

Gilbarco Polymer Handguard
(with or without Magnet)

Tokheim Polymer Handguard
(with or without Magnet)

Wayne Polymer Handguard
(with or without Magnet)

Latch Plate Options

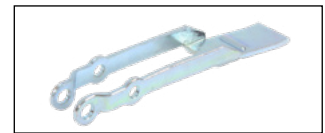

1 - Position Latch Plate

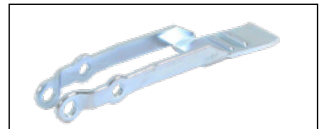

2 - Position Latch Plate

Lever Options



Lever without Hold Open Clip



Lever with Hold Open Clip

Flo-Equalizer[®] Option

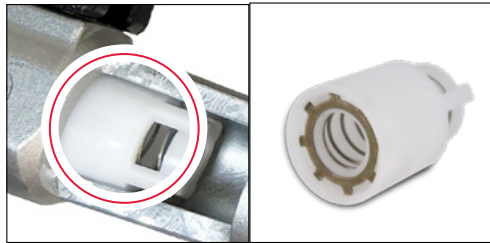

Sightglass Option



XS[®] MFM Nozzles

Pressure-activated, automatic shut-off nozzle for full-service and self-service stations.

System Options

Safe-T-Breaks[®]

MODEL NO.	DESCRIPTION
002276	1" F x 1" F NPT Reconnectable Safe-T-Break [®]
003076	1" F x 1" F BSPP Reconnectable Safe-T-Break [®]
003076A	1" F x 1" F BSPP Reconnectable Safe-T-Break [®] - Atex
005231	1" F x 1" F Low Pull NPT Reconnectable Safe-T-Break [®]
005812	1" F x 1" F NPT Non-Reconnectable Safe-T-Break [®]
006301	1" F x 1" F NPT Non-Reconnectable PCC Safe-T-Break [®]
006914	1" F x 1" F BSPP Non-Reconnectable Safe-T-Break [®]
008331	3/4" F x 3/4" F NPT CK Reconnectable MAGBREAK [®]
009911	3/4" F x 3/4" F BSPP Reconnectable G2 MAGBREAK [®]

Swivel/Safe-T-Break[®] Combos

MODEL NO.	DESCRIPTION
005969	1" M NPT Multi-Plane Swivel connected to 1" F NPT Reconnectable Safe-T-Break [®]
008015	1" M BSPP Multi-Plane Swivel connected to 1" F BSPP Reconnectable Safe-T-Break [®]
008015A	1" M BSPP Multi-Plane Swivel connected to 1" F BSPP Reconnectable Safe-T-Break [®] - Atex

Spouts

MODEL NO.	DESCRIPTION
001471	Light Duty Diesel Spout
001473	Unleaded Spout
010353	Light Duty Diesel Long Spout
010434	Unleaded Long Spout

Pressure/Vacuum Vents

MODEL NO.	DESCRIPTION
004620	2" Slip-On Pressure Vacuum Vent
004885	2" Thread-On Pressure Vacuum Vent - NPT
005885	2" Thread-On Pressure Vacuum Vent with Internal Screen - NPT

Accessories, Testing and Maintenance

MODEL NO.	DESCRIPTION
000397	Unleaded Spout Gauge
003593	Hold Open Clip Kit
004490	Conventional Flo-Equalizer [®] - 10 gpm / 37.9 Lpm
007089	Nozzle Service Kit
007490	Internal Flo-Equalizer [®] - 10 gpm / 37.9 Lpm

















Swivels

MODEL NO.	DESCRIPTION
000087	1" M x 1" F NPT Multi-Plane Swivel
000095	1" M x 1" F NPT 70° Multi-Plane Swivel
003306	1" M x 1" F BSPP Multi-Plane Swivel
003395	1" M x 1" F NPT Multi-Plane Restricted Swivel
004860	1" M x 1" F NPT Multi-Plane High Volume Swivel
006949	1" M x 1" F BSPP Multi-Plane High Volume Swivel

Guards

MODEL NO.	DESCRIPTION
001506	Protection Package
001806	Full Grip Reguard
001807	Waffle Splash Guard with Small Hole
001808	Waffle Splash Guard
001809	Reguard Protection Package
003440	Mate Easy-On Package
003795	Mate Guard
004145	Full Grip Guard
006628	POPD [®] S Clear Cover
006665	POPD [®] S Full Grip Guard
007205	POPD [®] S Full Grip Reguard
007361	Black Handle Cover
007999	POPD [®] H Clear Cover
008165	POPD [®] S Mate Guard
008166	POPD [®] H Mate Guard
008175	POPD [®] EZS Nozzle Guard
008176	POPD [®] EZH Nozzle Guard
008185	POPD [®] H Full Grip Guard
008192	POPD [®] H Full Grip Reguard
014524	International Mate Package
014530	International Mate Guard
015247	International POPD [®] H Mate Guard
015253	International POPD [®] H Mate Package

Guard Color Chart

COLOR	SUFFIX	COLOR	SUFFIX	COLOR <i>CUSTOM</i>	SUFFIX
	-01		-08		-07 <i>CUSTOM</i>
	-02		-09		-18 <i>CUSTOM</i>
	-03		-16		-19 <i>CUSTOM</i>
	-04		-21		-20 <i>CUSTOM</i>
	-05		-39		-22 <i>CUSTOM</i>
	-06				

Scuff Guards are to be ordered with the corresponding guard color option added to the model number. Example: If BLUE guards are desired, add guard color option -01 to the model number (159504-01). For custom colors, a minimum order of 4,000 guards will be required.

X Nozzles

CONVENTIONAL FUELLING

Automatic shut-off nozzle for full-service and self-service stations.

- X nozzle shuts off when the gas tank is full.
- Stainless steel reinforced spout bushing keeps spout tip round, and acts as a captive fastener to prevent tip-end sensor damage.
- Nozzle is equipped with a unique Flo-Stop® device that shuts off the nozzle if it falls from the fill neck or raises above the horizontal.
- StreamShaper® reduces turbulence for straighter fuel flow and less splash back spillage.
- Comes standard with smooth full grip guard
- Tilt poppet design provides precise “to-the-penny” dispensing.
- Optional cold weather seals are rated to -40° F/C.
- Optional sightglass provides a clear window for the customer to view the fuel as it passes through the main poppet valve.
- Optional Gilbarco, Tokheim, and Wayne handguards can be fitted with a magnet to trigger the dispenser’s proximity switch, or can be provided without the magnet for dispensers equipped with a standard “flapper” switch.
- Optional Flo-Equalizer® prohibits the nozzle from exceeding 10 gpm (37.9 Lpm).
- ADA-compliant EZ Lever reduces the force required to open the main poppet valve by 50%, resulting in a lever operating force ≤5 lbs.



MODEL NO.
159408

New Unleaded Nozzles with NPT Inlet

MODEL NO.	DESCRIPTION	SHIPPING WEIGHT LBS (KG)
159408	without Hold Open Clip	2.9 (1.3)
159468	without Hold Open Clip, with 1808 Waffle Splash Guard	3.0 (1.4)
498408	without Hold Open Clip, with Cold Weather Seals	2.9 (1.3)
498466	without Hold Open Clip, with 1808 Waffle Splash Guard and Cold Weather Seals	3.0 (1.4)
159404N^	with Two Notch Hold Open Clip	2.9 (1.3)
159404NR^	with Two Notch Hold Open Clip and Retail Packaging	2.9 (1.3)
159443N^	with Single Notch Hold Open Clip	2.9 (1.3)
159454N^	with Two Notch Hold Open Clip and Flo-Equalizer®	3.0 (1.4)
159459N^	with Two Notch Hold Open Clip and 1808 Waffle Splash Guard	3.0 (1.4)
159494N^	with Two Notch Hold Open Clip, POPD®S Full Grip Guard and 1808 Waffle Splash Guard	3.0 (1.4)
498404N^	with Two Notch Hold Open Clip and Cold Weather Seals	2.9 (1.3)
1400204N^	with Two Notch Hold Open Clip and Tokheim Magnetic Handguard	3.0 (1.4)
4984108	without Hold Open Clip, with POPD®S Full Grip Guard with 1808 Waffle Splash Guard, with Cold Weather Seals	3.0 (1.4)
E159404N^	with Two Notch Hold Open Clip, Mate Guard and Polymer Handle Cover	2.9 (1.3)
E1503004N^	with Two Notch Hold Open Clip, Wayne Magnetic Handguard, Mate Guard and Polymer Handle Cover	3.0 (1.4)
E159408	without Hold Open Clip with Mate Guard	2.9 (1.3)

^ NOT LISTED

New Unleaded Nozzles with BSP Inlet

MODEL NO.	DESCRIPTION	SHIPPING WEIGHT LBS (KG)
159416N^	with Two Notch Hold Open Clip	2.9 (1.3)
E159420N	without Hold Open Clip, with Mate Guard	2.9 (1.3)
1400216N^	with Two Notch Hold Open Clip and Tokheim Magnetic Handguard	3.0 (1.4)
E159416N^	with Two Notch Hold Open Clip, Mate Guard and Polymer Handle Cover	2.9 (1.3)
E1594165N	with Hold Open Clip, Mate Guard and 1808 Waffle Splash Guard	3.0 (1.4)

^ NOT LISTED



II 1 G
EN 13012
TYPE 1



P-TÜ7-8113626964

WARNING: Cancer and Reproductive Harm - www.P65Warnings.ca.gov

X Nozzles

Automatic shut-off nozzle for full-service and self-service stations.

Dimensions

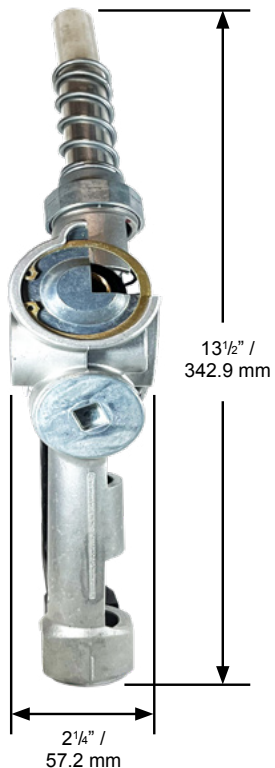
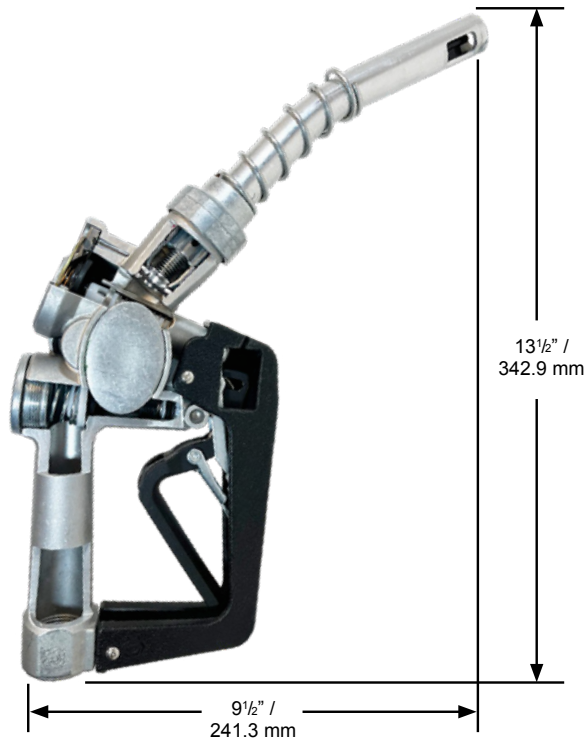

New Light Duty Diesel Nozzles with NPT Inlet

MODEL NO.	DESCRIPTION	SHIPPING WEIGHT LBS (KG)
159407	without Hold Open Clip	2.9 (1.3)
498407	without Hold Open Clip, with Cold Weather Seals	2.9 (1.3)
159403N^	with Two Notch Hold Open Clip	2.9 (1.3)
159463N^	with Two Notch Hold Open Clip and 1808 Waffle Splash Guard	3.0 (1.4)
498403N^	with Two Notch Hold Open Clip and Cold Weather Seals	2.9 (1.3)
4984109	without Hold Open Clip, with POPD®S Full Grip Guard with 1808 Waffle Splash Guard, with Cold Weather Seals	2.9 (1.3)
1400203N	with Two Notch Hold Open Clip and Tokheim Magnetic Handguard	3.0 (1.4)

^ NOT LISTED

New Light Duty Diesel Nozzles with BSP Inlet

MODEL NO.	DESCRIPTION	SHIPPING WEIGHT LBS (KG)
159415N^	with Two Notch Hold Open Clip	2.9 (1.3)
E159415N^	with Two Notch Hold Open Clip, Mate Guard and Polymer Handle Cover	2.9 (1.3)
E1400215N	with Two Notch Hold Open Clip, Tokheim Polymer Handguard, Mate Guard and Polymer Handle Cover	3.0 (1.4)

^ NOT LISTED

Construction

Body	One piece die cast aluminum with high-impact polymer handguard
Seals	Fluorocarbon
Packing	Double o-ring seal protected by fiber-reinforced Teflon®
Lever	Two piece polymer EZ lever
Inlet	3/4" (19 mm) NPT or 3/4" (19 mm) BSP

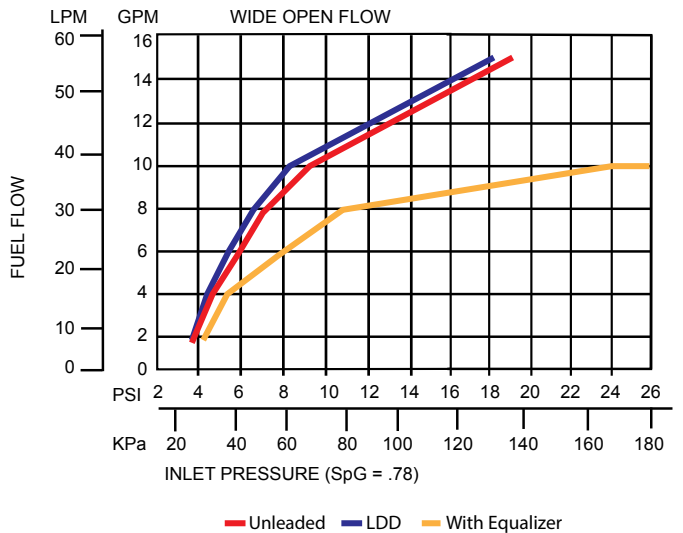

X Nozzles

CONVENTIONAL FUELLING

Automatic shut-off nozzle for full-service and self-service stations.

Nozzle Options

Nozzle Guard Options



Full Grip Guard

POPD®S Full Grip Guard

POPD®H Full Grip Guard

Mate Guard

POPD®S Mate Guard

POPD®H Mate Guard

Waffle Guard Options



1807 Waffle Guard



1808 Waffle Guard

Handguard Options



Standard Polymer Handguard

Gilbarco Polymer Handguard
(with or without Magnet)

Tokheim Polymer Handguard
(with or without Magnet)

Wayne Polymer Handguard
(with or without Magnet)

Latch Plate Options

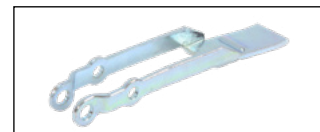

1 - Position Latch Plate

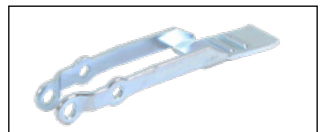

2 - Position Latch Plate

Lever Options



Lever without Hold Open Clip



Lever with Hold Open Clip

Flo-Equalizer® Option



Sightglass Option



X Nozzles

Automatic shut-off nozzle for full-service and self-service stations.

System Options

Safe-T-Breaks®

MODEL NO.	DESCRIPTION
002273	3/4" F x 3/4" F NPT Non-Reconnectable Safe-T-Break®
002774	3/4" F x 3/4" F BSPP Non-Reconnectable Safe-T-Break®
003360	3/4" F x 3/4" F NPT Reconnectable Safe-T-Break®
003385	3/4" F x 3/4" F BSPP Reconnectable Safe-T-Break®
005230	3/4" F x 3/4" F NPT Low Pull Reconnectable Safe-T-Break®
006130	3/4" F x 3/4" F NPT Non-Reconnectable PCC Safe-T-Break®
008330	3/4" F x 3/4" F NPT Reconnectable MAGBREAK®
009910	3/4" F x 3/4" F BSPP Reconnectable MAGBREAK®
010328	3/4" F x 3/4" F NPT Reconnectable High Pull MAGBREAK®
010330	3/4" F x 3/4" F BSPP Reconnectable High Pull MAGBREAK®
002774A	3/4" F x 3/4" F BSPP Non-Reconnectable Safe-T-Break® - Atex
003385A	3/4" F x 3/4" F BSPP Reconnectable Safe-T-Break® - Atex

Swivel/Safe-T-Break® Combos

MODEL NO.	DESCRIPTION
006310	3/4" M NPT Multi-Plane Swivel connected to 3/4" F NPT Reconnectable Safe-T-Break®
007085	3/4" M BSPP Multi-Plane Swivel connected to 3/4" F BSPP Reconnectable Safe-T-Break®
007085A	3/4" M BSPP Multi-Plane Swivel connected to 3/4" F BSPP Reconnectable Safe-T-Break® - Atex

Spouts

MODEL NO.	DESCRIPTION
001471	Light Duty Diesel Spout
001473	Unleaded Spout
010353	Light Duty Diesel Long Spout
010434	Unleaded Long Spout

Pressure/Vacuum Vents

MODEL NO.	DESCRIPTION
004620	2" Slip-On Pressure Vacuum Vent
004885	2" Thread-On Pressure Vacuum Vent - NPT
005885	2" Thread-On Pressure Vacuum Vent with Internal Screen - NPT

Accessories, Testing and Maintenance

MODEL NO.	DESCRIPTION
000397	Unleaded Spout Gauge
003593	Hold Open Clip Kit
004490	Conventional Flo-Equalizer® - 10 gpm / 37.9 Lpm
007089	Nozzle Service Kit
007490	Internal Flo-Equalizer® - 10 gpm / 37.9 Lpm

Swivels

MODEL NO.	DESCRIPTION
000350	3/4" M x 3/4" F NPT Multi-Plane Swivel
000355	3/4" M x 3/4" F NPT Multi-Plane Swivel Anodized Black
002272	3/4" M x 3/4" F NPT 90° Pump Swivel
002771	3/4" M x 3/4" F BSPP 90° Pump Swivel
002950	3/4" M x 3/4" F NPT Multi-Plane Restricted Swivel
003590	3/4" M x 3/4" F BSPP Multi-Plane Swivel
003895	3/4" M x 3/4" F NPT Inline Swivel
002771A	3/4" M x 3/4" F BSPP 90° Pump Swivel - Atex
003590A	3/4" M x 3/4" F BSPP Multi-Plane Swivel - Atex

Guards

MODEL NO.	DESCRIPTION
001506	Protection Package
001806	Full Grip Reguard
001807	Waffle Splash Guard with Small Hole
001808	Waffle Splash Guard
001809	Reguard Protection Package
003440	Mate Easy-On Package
003795	Mate Guard
004145	Full Grip Guard
006628	POPD® S Clear Cover
006665	POPD® S Full Grip Guard
007205	POPD® S Full Grip Reguard
007361	Black Handle Cover
007999	POPD® H Clear Cover
008165	POPD® S Mate Guard
008166	POPD® H Mate Guard
008175	POPD® EZS Nozzle Guard
008176	POPD® EZH Nozzle Guard
008185	POPD® H Full Grip Guard
008192	POPD® H Full Grip Reguard
014524	International Mate Package
014530	International Mate Guard
015247	International POPD® H Mate Guard
015253	International POPD® H Mate Package

Guard Color Chart

COLOR	SUFFIX	COLOR	SUFFIX	COLOR <small>CUSTOM</small>	SUFFIX
Blue	-01	Gold	-08	Amoco Blue	-07 <small>CUSTOM</small>
Red	-02	Silver	-09	Apple Green	-18 <small>CUSTOM</small>
Green	-03	BP Green	-16	Purple	-19 <small>CUSTOM</small>
Black	-04	M Blue	-21	Pink	-20 <small>CUSTOM</small>
Yellow	-05	Orange	-39	BPS Green	-22 <small>CUSTOM</small>
White	-06				

Scuff Guards are to be ordered with the corresponding guard color option added to the model number. Example: If BLUE guards are desired, add guard color option -01 to the model number (159504-01). For custom colors, a minimum order of 4,000 guards will be required.

1A Nozzles

Automatic shut-off nozzle for full-service and self-service stations.

- 1A nozzle shuts off when the gas tank is full.
- Stainless steel reinforced spout bushing keeps spout tip round, and acts as a captive fastener to prevent tip-end sensor damage.
- Nozzle is equipped with a unique Flo-Stop® device the shuts off the nozzle if it falls from the fill neck or raises above the horizontal.
- StreamShaper® reduces turbulence for straighter fuel flow and less splash back spillage.
- Comes standard with smooth full grip guard
- Optional tilt poppet design provides precise “to-the-penny” dispensing.
- Optional cold weather seals are rated to -40 °F/C.
- Optional Gilbarco, Tokheim, and Wayne handguards can be fitted with a magnet to trigger the dispenser’s proximity switch, or can be provided without the magnet for dispensers equipped with a standard “flapper” switch.
- ADA-compliant EZ Lever reduces the force required to open the main poppet valve by 50%, resulting in a lever operating force ≤5 lbs.



MODEL NO.
209808

New Unleaded PHG Nozzles with NPT Inlet

MODEL NO.	DESCRIPTION	SHIPPING WEIGHT LBS (KG)
209808	without Hold Open Clip, with Polymer Handguard	3.3 (1.4)
209866	without Hold Open Clip, with Polymer Handguard and 1808 Waffle Splash Guard	3.4 (1.5)
209804N^	with Two Notch Hold Open Clip and Polymer Handguard	3.3 (1.4)
209859N^	with Two Notch Hold Open Clip, Polymer Handguard and 1808 Waffle Splash Guard	3.4 (1.5)
209872N^	with Two Notch Hold Open Clip, Polymer Handguard, 1808 Waffle Splash Guard and 385 Reducer Bushing	3.5 (1.6)

^ NOT LISTED

New Unleaded PHG Nozzles with BSP Inlet

MODEL NO.	DESCRIPTION	SHIPPING WEIGHT LBS (KG)
209816N^	with Two Notch Hold Open Clip and Polymer Handguard	3.5 (1.6)

^ NOT LISTED

New Light Duty Diesel PHG Nozzles with NPT Inlet

MODEL NO.	DESCRIPTION	SHIPPING WEIGHT LBS (KG)
209807	without Hold Open Clip, with Polymer Handguard	3.3 (1.4)
209803N^	with Two Notch Hold Open Clip and Polymer Handguard	3.3 (1.4)
2098208N^	with Two Notch Hold Open Clip, Polymer Handguard and 385 Reducer Bushing	3.4 (1.5)
209861N^	with Two Notch Hold Open Clip, Polymer Handguard and 1808 Waffle Splash Guard	3.5 (1.6)

^ NOT LISTED

New Light Duty Diesel PHG Nozzles with BSP Inlet

MODEL NO.	DESCRIPTION	SHIPPING WEIGHT LBS (KG)
209815N^	with Two Notch Hold Open Clip and Polymer Handguard	3.3 (1.4)
E1064715N^	with Two Notch Hold Open Clip, Polymer Handguard, Mate Guard and Polymer Handle Cover, without UL Spout Groove	3.3 (1.4)

^ NOT LISTED



WARNING: Cancer and Reproductive Harm - www.P65Warnings.ca.gov

1A Nozzles

Automatic shut-off nozzle for full-service and self-service stations.

Dimensions

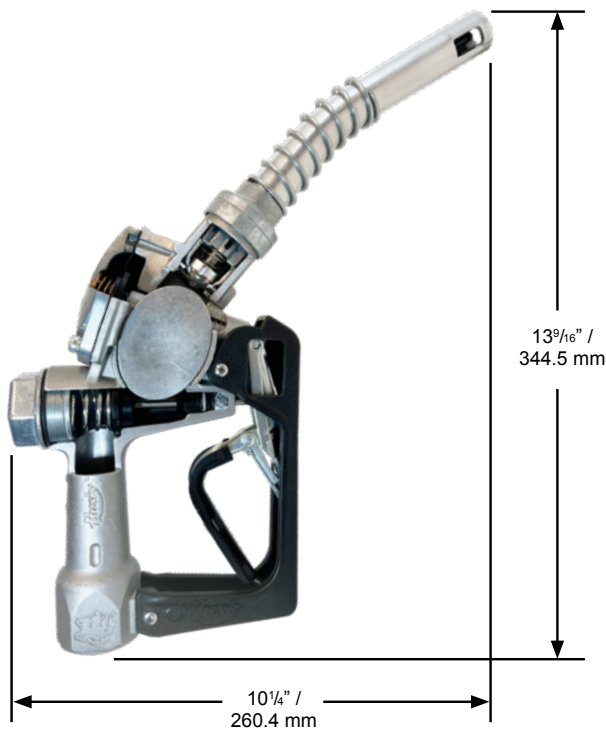

New Unleaded MHG Nozzles with NPT Inlet

696108	without Hold Open Clip, with Metal Handguard	3.5 (1.6)
696104N^	with Two Notch Hold Open Clip and Metal Handguard	3.5 (1.6)
696159N^	with Two Notch Hold Open Clip, Metal Handguard and 1808 Waffle Splash Guard	3.6 (1.6)
696172N^	with Two Notch Hold Open Clip, Metal Handguard, 1808 Waffle Splash Guard and 385 Reducer Bushing	3.7 (1.7)

New Light Duty Diesel MHG Nozzles with NPT Inlet

696103N^	with Two Notch Hold Open Clip and Metal Handguard	3.5 (1.6)
696161N^	with Two Notch Hold Open Clip, Metal Handguard and 1808 Waffle Splash Guard	3.6 (1.6)

^ NOT LISTED

Construction

Body	One piece die cast aluminum with high-impact polymer or metal handguard
Seals	Fluorocarbon
Packing	Double o-ring seal protected by fiber-reinforced Teflon®
Lever	Two-piece polymer EZ Lever
Inlet	1" (25.4 mm) NPT or 1" (25.4 mm) BSP

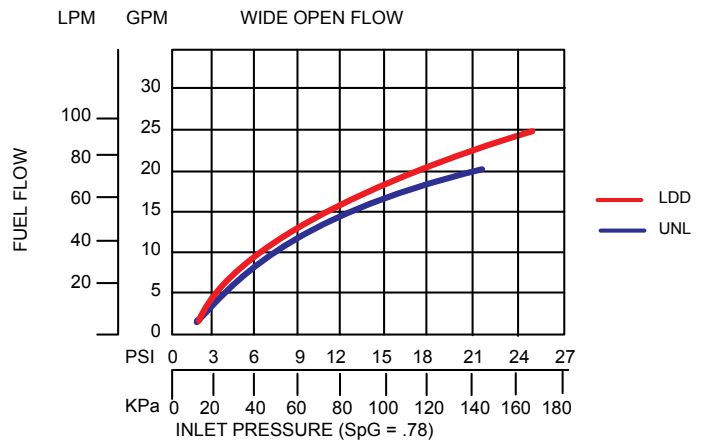

1A Nozzles

Automatic shut-off nozzle for full-service and self-service stations.

Nozzle Options

Nozzle Guard Options



Full Grip Guard

POPD[®]S
Full Grip Guard

POPD[®]H
Full Grip Guard

Mate Guard

POPD[®]S
Mate Guard

POPD[®]H
Mate Guard

Waffle Guard Options



1808 Waffle Guard

Reducer Bushing



000385

Handguard Options



Standard Polymer
Handguard

Standard Metal
Handguard

Gilbarco Polymer
Handguard
(with or without Magnet)

Tokheim Polymer
Handguard
(with or without Magnet)

Wayne Polymer
Handguard
(with or without Magnet)

Lever Options

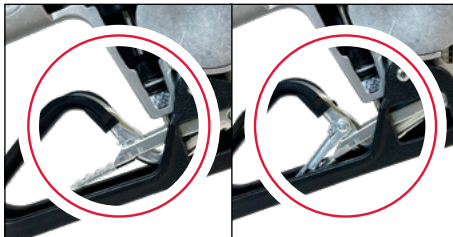

Lever without Hold
Open Clip

Lever with Hold
Open Clip

Latch Plate Options



1 - Position Latch Plate

2 - Position Latch Plate

1A Nozzles

Automatic shut-off nozzle for full-service and self-service stations.

System Options

Safe-T-Breaks®

MODEL NO.	DESCRIPTION
002276	1" F x 1" F NPT Reconnectable Safe-T-Break®
003076	1" F x 1" F BSPP Reconnectable Safe-T-Break®
003076A	1" F x 1" F BSPP Reconnectable Safe-T-Break® - Atex
005231	1" F x 1" F Low Pull NPT Reconnectable Safe-T-Break®
005812	1" F x 1" F NPT Non-Reconnectable Safe-T-Break®
006301	1" F x 1" F NPT Non-Reconnectable PCC Safe-T-Break®
006914	1" F x 1" F BSPP Non-Reconnectable Safe-T-Break®
008331	1" F x 1" F NPT CK Reconnectable MAGBREAK®
009911	1" F x 1" F BSPP Reconnectable G2 MAGBREAK®

Swivel/Safe-T-Break® Combos

MODEL NO.	DESCRIPTION
005969	1" M NPT Multi-Plane Swivel connected to 1" F NPT Reconnectable Safe-T-Break®
008015	1" M BSPP Multi-Plane Swivel connected to 1" F BSPP Reconnectable Safe-T-Break®
008015A	1" M BSPP Multi-Plane Swivel connected to 1" F BSPP Reconnectable Safe-T-Break® - Atex Spouts

Spouts

MODEL NO.	DESCRIPTION
001471	Light Duty Diesel Spout
001473	Unleaded Spout
010353	Light Duty Diesel Long Spout
010434	Unleaded Long Spout

Pressure/Vacuum Vents

MODEL NO.	DESCRIPTION
004620	2" Slip-On Pressure Vacuum Vent
004885	2" Thread-On Pressure Vacuum Vent - NPT
005885	2" Thread-On Pressure Vacuum Vent with Internal Screen - NPT

Accessories, Testing and Maintenance

MODEL NO.	DESCRIPTION
000385	1" M x 3/4" F Reducer Bushing
000397	Unleaded Spout Gauge
003593	Hold Open Clip Kit
007089	Nozzle Service Kit

Swivels

MODEL NO.	DESCRIPTION
000087	1" M x 1" F NPT Multi-Plane Swivel
000095	1" M x 1" F NPT 70° Multi-Plane Swivel
000352	1" M x 3/4" F NPT Multi-Plane Swivel
000356	1" M x 3/4" F NPT Multi-Plane Swivel Anodized Black
003306	1" M x 1" F BSPP Multi-Plane Swivel
003306A	1" M x 1" F BSPP Multi-Plane Swivel - Atex
003395	1" M x 1" F NPT Multi-Plane Restricted Swivel
004860	1" M x 1" F NPT Multi-Plane High Volume Swivel
006949	1" M x 1" F BSPP Multi-Plane High Volume Swivel

Guards

MODEL NO.	DESCRIPTION
000099	Protection Package
000226	Mate Nozzle Guard
000554	Full Grip Guard
001804	Full Grip Reguard
001808	Waffle Splash Guard
001811	Reguard Protection Package
005494	Lever Guard
006628	POPD® S Clear Cover
001808	Protection Package
006655	POPD® S Full Grip Guard
007210	POPD® S Full Grip Reguard
007999	POPD® H Clear Cover
008169	POPD® S Mate Nozzle Guard
008170	POPD® H Mate Nozzle Guard
008179	POPD® EZS Nozzle Guard
008180	POPD® EZH Nozzle Guard
008183	POPD® H Full Grip Guard
008190	POPD® H Full Grip Reguard

Guard Color Chart

COLOR	SUFFIX	COLOR	SUFFIX	COLOR <i>CUSTOM</i>	SUFFIX
Blue	-01	Gold	-08	Amoco Blue	-07 <i>CUSTOM</i>
Red	-02	Silver	-09	Apple Green	-18 <i>CUSTOM</i>
Green	-03	BP Green	-16	Purple	-19 <i>CUSTOM</i>
Black	-04	M Blue	-21	Pink	-20 <i>CUSTOM</i>
Yellow	-05	Orange	-39	BPS Green	-22 <i>CUSTOM</i>
White	-06				

Scuff Guards are to be ordered with the corresponding guard color option added to the model number. Example: If BLUE guards are desired, add guard color option -01 to the model number (159504-01). For custom colors, a minimum order of 4,000 guards will be required.

1AS Nozzles

Pressure-activated, automatic shut-off nozzle for full-service and self-service stations.

- 1AS nozzle shuts off when:
 - the pump shuts off
 - the gas tank is full
 - the lever is opened before the pump is turned on
 - the leak detector has not completed the test cycle
- Optional tilt poppet design provides precise “to-the-penny” dispensing.
- Optional cold weather seals are rated to -40° F/C.
- Optional Gilbarco, Tokheim, and Wayne handguards can be fitted with a magnet to trigger the dispenser’s proximity switch, or can be provided without the magnet for dispensers equipped with a standard “flapper” switch.
- ADA-compliant EZ Lever reduces the force required to open the main poppet valve by 50%, resulting in a lever operating force ≤5 lbs.
- Stainless steel reinforced spout bushing keeps spout tip round, and acts as a captive fastener to prevent tip-end sensor damage.
- Nozzle is equipped with a unique Flo-Stop® device that shuts off the nozzle if it falls from the fill neck or raises above the horizontal.
- StreamShaper® reduces turbulence for straighter fuel flow and less splash back spillage.
- Comes standard with smooth full grip guard

New Unleaded PHG Nozzles with NPT Inlet

MODEL NO.	DESCRIPTION	SHIPPING WEIGHT LBS (KG)
1215904	with Two Notch Hold Open Clip and Polymer Handguard	3.3 (1.4)
12159209	with Two Notch Hold Open Clip, Polymer Handguard and 385 Reducer Bushing	3.4 (1.5)

New Light Duty Diesel PHG Nozzles with NPT Inlet

MODEL NO.	DESCRIPTION	SHIPPING WEIGHT LBS (KG)
1215903	with Two Notch Hold Open Clip and Polymer Handguard	3.3 (1.4)
1215961	with Two Notch Hold Open Clip, Polymer Handguard and 1808 Waffle Splash Guard	3.4 (1.5)
1398903	with Two Notch Hold Open Clip, Polymer Handguard and Cold Weather Seals	3.3 (1.4)
12159208	with Two Notch Hold Open Clip, Polymer Handguard and 385 Reducer Bushing	3.4 (1.5)
E1215903	with Two Notch Hold Open Clip, Polymer Handguard, Mate Guard and Polymer Handle Cover	3.3 (1.4)
12159263A*	with Two Notch Hold Open Clip, Polymer Handguard, 1808 Waffle Splash Guard and Inlet Screen, Atex	3.4 (1.5)
1215903N^	with Two Notch Hold Open Clip and Polymer Handguard	3.3 (1.4)
1691103N^	with Two Notch Hold Open Clip, Polymer Handguard, 1808 Waffle Splash Guard and Cold Weather Seals	3.3 (1.4)

New Light Duty Diesel PHG Nozzles with M34 Inlet

MODEL NO.	DESCRIPTION	SHIPPING WEIGHT LBS (KG)
E12159294N^	with Two Notch Hold Open Clip and Polymer Handguard	3.3 (1.4)

^ NOT LISTED



MODEL NO.
1215904



WARNING: Cancer and Reproductive Harm - www.P65Warnings.ca.gov

1AS Nozzles

Pressure-activated, automatic shut-off nozzle for full-service and self-service stations.

Dimensions

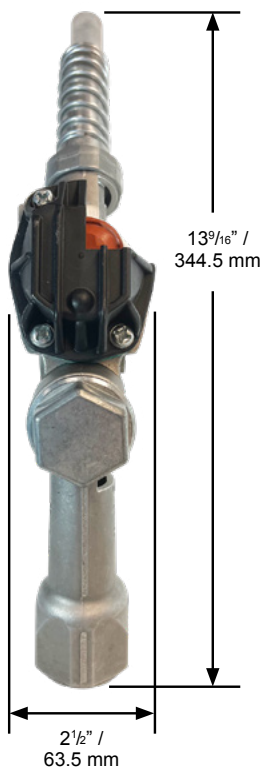
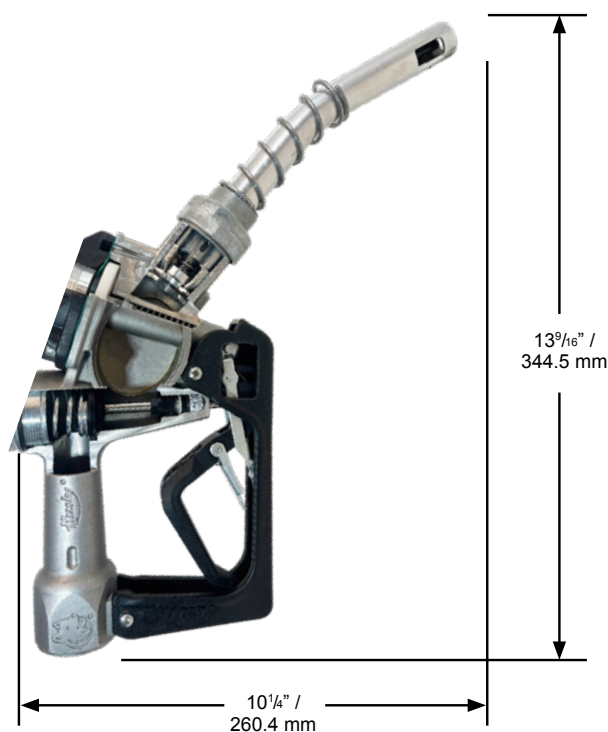

New Unleaded MHG Nozzles with NPT Inlet

MODEL NO.	DESCRIPTION	SHIPPING WEIGHT LBS (KG)
1216204	with Two Notch Hold Open Clip and Metal Handguard	3.5 (1.6)

New Light Duty Diesel MHG Nozzles with NPT Inlet

MODEL NO.	DESCRIPTION	SHIPPING WEIGHT LBS (KG)
1216203	with Two Notch Hold Open Clip and Metal Handguard	3.5 (1.6)
1399203	with Two Notch Hold Open Clip, Metal Handguard and Cold Weather Seals	3.5 (1.6)

New Light Duty Diesel MHG Nozzles with M34 Inlet

MODEL NO.	DESCRIPTION	SHIPPING WEIGHT LBS (KG)
E16576294N^	with Two Notch Hold Open Clip, Metal Handguard and Cold Weather Seals	3.5 (1.6)

Construction

Body	One piece die cast aluminum with high-impact polymer or metal handguard
Seals	Fluorocarbon
Packing	Double o-ring seal protected by fiber-reinforced Teflon®
Lever	Two piece polymer EZ Lever
Inlet	1" (25.4 mm) NPT, 1" (25.4 mm) BSP or M34 x 1.5 mm

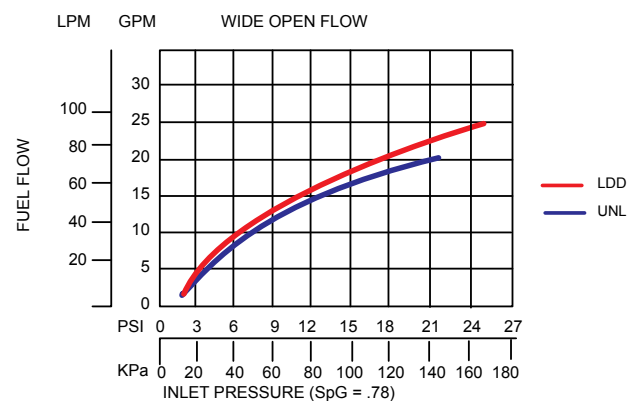

1AS Nozzles

Pressure-activated, automatic shut-off nozzle for full-service and self-service stations.

Nozzle Options

Nozzle Guard Options



Full Grip Guard

POPD®S Full Grip Guard

POPD®H Full Grip Guard

Mate Guard

POPD®S Mate Guard

POPD®H Mate Guard

Waffle Guard Options



1808 Waffle Guard

Reducer Bushing



000385

Handguard Options



Standard Polymer Handguard

Standard Metal Handguard

Gilbarco Polymer Handguard

(with or without Magnet)

Tokheim Polymer Handguard

(with or without Magnet)

Wayne Polymer Handguard

(with or without Magnet)

Lever Options

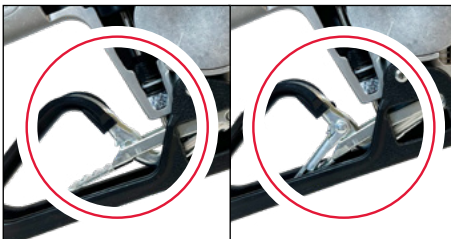

Lever without Hold Open Clip

Lever with Hold Open Clip

Latch Plate Options

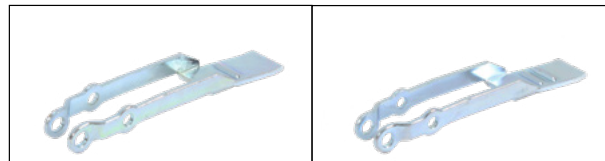

1 - Position Latch Plate

2 - Position Latch Plate

1AS Nozzles

Pressure-activated, automatic shut-off nozzle for full-service and self-service stations.

System Options

Safe-T-Breaks®

MODEL NO.	DESCRIPTION
002276	1" F x 1" F NPT Reconnectable Safe-T-Break®
003076	1" F x 1" F BSPP Reconnectable Safe-T-Break®
003076A	1" F x 1" F BSPP Reconnectable Safe-T-Break® - Atex
005231	1" F x 1" F Low Pull NPT Reconnectable Safe-T-Break®
005812	1" F x 1" F NPT Non-Reconnectable Safe-T-Break®
006301	1" F x 1" F NPT Non-Reconnectable PCC Safe-T-Break®
006914	1" F x 1" F BSPP Non-Reconnectable Safe-T-Break®
008331	1" F x 1" F NPT CK Reconnectable MAGBREAK®
009911	1" F x 1" F BSPP Reconnectable G2 MAGBREAK®

Swivel/Safe-T-Break® Combos

MODEL NO.	DESCRIPTION
005969	1" M NPT Multi-Plane Swivel connected to 1" F NPT Reconnectable Safe-T-Break®
008015	1" M BSPP Multi-Plane Swivel connected to 1" F BSPP Reconnectable Safe-T-Break®
008015A	1" M BSPP Multi-Plane Swivel connected to 1" F BSPP Reconnectable Safe-T-Break® - Atex Spouts

Spouts

MODEL NO.	DESCRIPTION
001471	Light Duty Diesel Spout
001473	Unleaded Spout
010353	Light Duty Diesel Long Spout
010434	Unleaded Long Spout

Pressure/Vacuum Vents

MODEL NO.	DESCRIPTION
004620	2" Slip-On Pressure Vacuum Vent
004885	2" Thread-On Pressure Vacuum Vent - NPT
005885	2" Thread-On Pressure Vacuum Vent with Internal Screen - NPT

Accessories, Testing and Maintenance

MODEL NO.	DESCRIPTION
000385	1" M x 3/4" F Reducer Bushing
000397	Unleaded Spout Gauge
003593	Hold Open Clip Kit
007089	Nozzle Service Kit

Swivels

MODEL NO.	DESCRIPTION
000087	1" M x 1" F NPT Multi-Plane Swivel
000095	1" M x 1" F NPT 70° Multi-Plane Swivel
000352	1" M x 3/4" F NPT Multi-Plane Swivel
000356	1" M x 3/4" F NPT Multi-Plane Swivel Anodized Black
003306	1" M x 1" F BSPP Multi-Plane Swivel
003306A	1" M x 1" F BSPP Multi-Plane Swivel - Atex
003395	1" M x 1" F NPT Multi-Plane Restricted Swivel
004860	1" M x 1" F NPT Multi-Plane High Volume Swivel
006949	1" M x 1" F BSPP Multi-Plane High Volume Swivel

Guards

MODEL NO.	DESCRIPTION
001807	Waffle Splash Guard with Smaller Hole
001808	Waffle Splash Guard
005494	Lever Guard
012164	Full Grip Guard

Guard Color Chart

COLOR	SUFFIX	COLOR	SUFFIX	COLOR <i>CUSTOM</i>	SUFFIX
Blue	-01	Gold	-08	Amoco Blue	-07 <i>CUSTOM</i>
Red	-02	Silver	-09	Apple Green	-18 <i>CUSTOM</i>
Green	-03	BP Green	-16	Purple	-19 <i>CUSTOM</i>
Black	-04	M Blue	-21	Pink	-20 <i>CUSTOM</i>
Yellow	-05	Orange	-39	BPS Green	-22 <i>CUSTOM</i>
White	-06				

Scuff Guards are to be ordered with the corresponding guard color option added to the model number. Example: If BLUE guards are desired, add guard color option -01 to the model number (159504-01). For custom colors, a minimum order of 4,000 guards will be required.

ECO Nozzles

Automatic shut-off conventional nozzle equipped with mechanical interlock.

- ECO nozzle shuts off when:
 - the gas tank is full
 - the mechanical interlock is disengaged, or the nozzle falls from the vehicle's fill pipe
- Nozzle is also equipped with a unique Flo-Stop® device that shuts off the nozzle if it falls from the fill neck or raises above the horizontal for added security.
- Stainless steel reinforced spout bushing keeps spout tip round, and acts as a captive fastener to prevent tip-end sensor damage.
- *StreamShaper*® reduces turbulence for straighter fuel flow and less splash back spillage.
- Drip Less spout reduces/eliminates drips from spout.
- Lightest insertion "force" of any safety interlock-operated nozzle
- Aluminum casting with high-impact polymer handguard provides a lightweight, easier to handle conventional nozzle.
- Unique tilt poppet design provides precise "to-the-penny" dispensing.
- Optional cold weather seals are rated to -40° F/C.
- CARB certified per CP-207 for drips, spills, spitting and liquid retention
- Comes standard with smooth full grip guard
- ADA-compliant EZ Lever reduces the force required to open the main poppet valve by 50%, resulting in a lever operating force ≤5 lbs.
- All seals are UL approved fluorocarbon compounds to prevent degradation from ethanol blends.
- Compatible with unleaded and all ethanol blends through E-25



MODEL NO.
1190404

New Unleaded PHG Nozzles with NPT Inlet

MODEL NO.	DESCRIPTION	SHIPPING WEIGHT LBS (KG)
1190404*	with Two Notch Hold Open Clip	2.8 (1.3)
1190408*	without Hold Open Clip	2.8 (1.3)
1474504	with Two Notch Hold Open Clip and Cold Weather Seals	2.8 (1.3)
11904180*	with Two Notch Hold Open Clip and Flo-Equalizer®	2.8 (1.3)
E1190404*	without Hold Open Clip, with Mate Guard and Polymer Handle Cover	2.8 (1.3)

New Unleaded Nozzles with BSP Inlet

MODEL NO.	DESCRIPTION	SHIPPING WEIGHT LBS (KG)
E1190416*	with Two Notch Hold Open Clip, with Mate Guard and Polymer Handle Cover	2.8 (1.3)
1190416*	with Two Notch Hold Open Clip	2.8 (1.3)

New E25 Nozzles with NPT Inlet

MODEL NO.	DESCRIPTION	SHIPPING WEIGHT LBS (KG)
1708404	with Two Notch Hold Open Clip	2.8 (1.3)
E1708404	with Two Notch Hold Open Clip, Mate Guard and Polymer Handle Cover	2.8 (1.3)



WARNING: Cancer and Reproductive Harm - www.P65Warnings.ca.gov

ECO Nozzles

Pressure-activated, automatic shut-off nozzle for full-service and self-service stations.

Dimensions

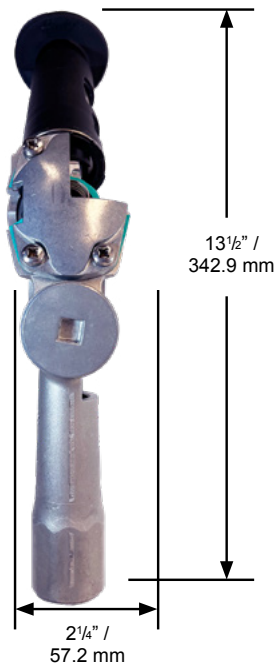
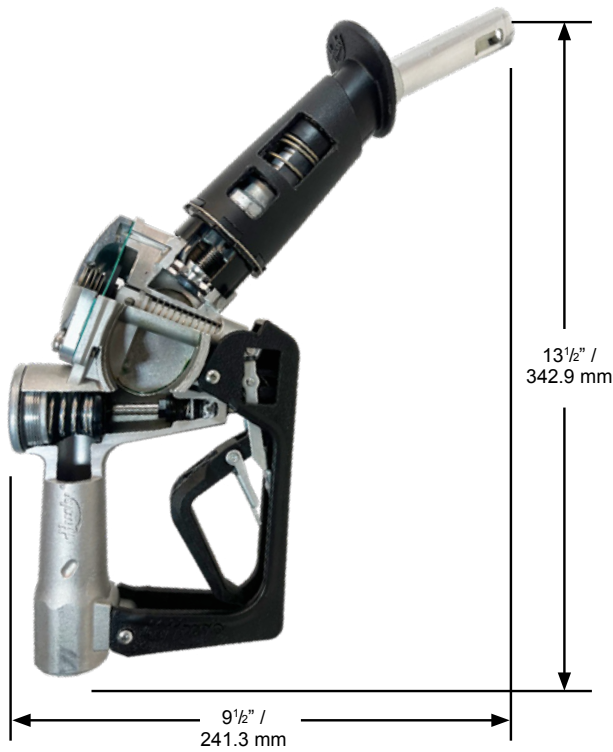

Construction

Body	One piece die cast aluminum with high-impact polymer handguard
Seals	Fluorocarbon
Packing	Double o-ring seal protected by fiber-reinforced Teflon®
Lever	Two piece polymer EZ Lever
Inlet	3/4" (19 mm) NPT or 3/4" (19 mm) BSP

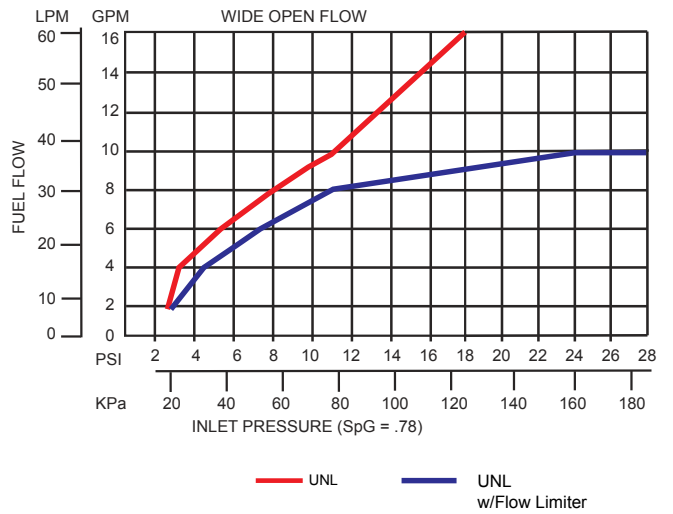

ECO Nozzles

CONVENTIONAL FUELLING

Pressure-activated, automatic shut-off nozzle for full-service and self-service stations.

Nozzle Options

Nozzle Guard Options



Full Grip Guard

POPD®S
Full Grip Guard

POPD®H
Full Grip Guard

Mate Guard

POPD®S
Mate Guard

POPD®H
Mate Guard

Lever Options

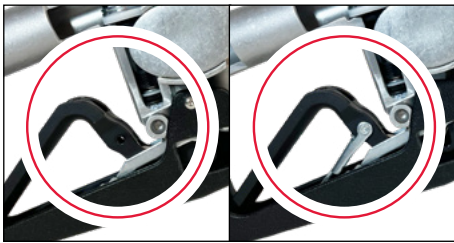

Lever without Hold
Open Clip

Lever with Hold
Open Clip

Flo-Equalizer® Option

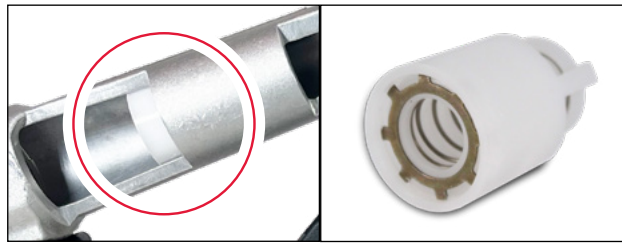

Latch Plate Options

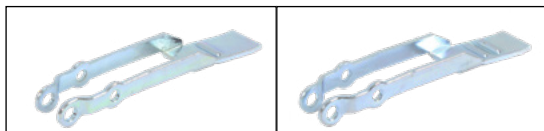

1 - Position Latch Plate

2 - Position Latch Plate

ECO Nozzles

Pressure-activated, automatic shut-off nozzle for full-service and self-service stations.

System Options

Safe-T-Breaks®

MODEL NO.	DESCRIPTION
002273	3/4" F x 3/4" F NPT Non-Reconnectable Safe-T-Break®
002774	3/4" F x 3/4" F BSPP Non-Reconnectable Safe-T-Break®
003360	3/4" F x 3/4" F NPT Reconnectable Safe-T-Break®
003385	3/4" F x 3/4" F BSPP Reconnectable Safe-T-Break®
005230	3/4" F x 3/4" F NPT Low Pull Reconnectable Safe-T-Break®
006130	3/4" F x 3/4" F NPT Non-Reconnectable PCC Safe-T-Break®
008330	3/4" F x 3/4" F NPT Reconnectable MAGBREAK®
009910	3/4" F x 3/4" F BSPP Reconnectable MAGBREAK®
010328	3/4" F x 3/4" F NPT Reconnectable High Pull MAGBREAK®
010330	3/4" F x 3/4" F BSPP Reconnectable High Pull MAGBREAK®
002774A	3/4" F x 3/4" F BSPP Non-Reconnectable Safe-T-Break® - Atex
003385A	3/4" F x 3/4" F BSPP Reconnectable Safe-T-Break® - Atex

Swivel/Safe-T-Break® Combos

MODEL NO.	DESCRIPTION
006310	3/4" M NPT Multi-Plane Swivel connected to 3/4" F NPT Reconnectable Safe-T-Break®
007085	3/4" M BSPP Multi-Plane Swivel connected to 3/4" F BSPP Reconnectable Safe-T-Break®
007085A	3/4" M BSPP Multi-Plane Swivel connected to 3/4" F BSPP Reconnectable Safe-T-Break® - Atex

Spouts

MODEL NO.	DESCRIPTION
013664	Unleaded ECO Spout Assembly Kit

Pressure/Vacuum Vents

MODEL NO.	DESCRIPTION
004620	2" Slip-On Pressure Vacuum Vent
004885	2" Thread-On Pressure Vacuum Vent - NPT
005885	2" Thread-On Pressure Vacuum Vent with Internal Screen - NPT

Accessories, Testing and Maintenance

MODEL NO.	DESCRIPTION
000397	Unleaded Spout Gauge
003593	Hold Open Clip Kit
004490	Conventional Flo-Equalizer® - 10 gpm / 37.9 Lpm
007089	Nozzle Service Kit
007490	Internal Flo-Equalizer® - 10 gpm / 37.9 Lpm

Swivels

MODEL NO.	DESCRIPTION
000350	3/4" M x 3/4" F NPT Multi-Plane Swivel
000355	3/4" M x 3/4" F NPT Multi-Plane Swivel Anodized Black
002272	3/4" M x 3/4" F NPT 90° Pump Swivel
002771	3/4" M x 3/4" F BSPP 90° Pump Swivel
002950	3/4" M x 3/4" F NPT Multi-Plane Restricted Swivel
003590	3/4" M x 3/4" F BSPP Multi-Plane Swivel
003895	3/4" M x 3/4" F NPT Inline Swivel
002771A	3/4" M x 3/4" F BSPP 90° Pump Swivel - Atex
003590A	3/4" M x 3/4" F BSPP Multi-Plane Swivel - Atex

Guards

MODEL NO.	DESCRIPTION
014034	Full Grip Nozzle Guard
016424	Mate Guard
016425	Handle Cover
016423	Mate Guard & Handle Cover Kit

Low Perm Hoses

MODEL NO.	DESCRIPTION
CP12LP8.5	3/4" Low Perm Hardwall 8.5' Assembly Hose
CP12LP8.5SV	3/4" Low Perm Hardwall 8.5' Assembly Hose Swivel
CP12LP9	3/4" Low Perm Hardwall 9' Assembly Hose
CP12LP9SV	3/4" Low Perm Hardwall 9' Assembly Hose Swivel
CP12LP.75	3/4" Low Perm Hardwall 9' Assembly Hose
CP12LP.75SV	3/4" Low Perm Hardwall 9' Assembly Hose Swivel

Guard Color Chart

COLOR	SUFFIX	COLOR	SUFFIX	COLOR <i>CUSTOM</i>	SUFFIX
Blue	-01	Gold	-08	Amoco Blue	-07 <i>CUSTOM</i>
Red	-02	Silver	-09	Apple Green	-18 <i>CUSTOM</i>
Green	-03	BP Green	-16	Purple	-19 <i>CUSTOM</i>
Black	-04	M Blue	-21	Pink	-20 <i>CUSTOM</i>
Yellow	-05	Orange	-39	BPS Green	-22 <i>CUSTOM</i>
White	-06				

Scuff Guards are to be ordered with the corresponding guard color option added to the model number. Example: If BLUE guards are desired, add guard color option -01 to the model number (159504-01). For custom colors, a minimum order of 4,000 guards will be required.



GENERAL FUELING PRODUCTS

Truck & High Volume Nozzles

VIIIS Nozzles

Pressure Activated, automatic shut-off nozzle for truck stop and other high volume full-service, self-service and unattended stations.

- VIIIS nozzle shuts off when:
 - the pump shuts off
 - the gas tank is full
 - the lever is opened before the pump is turned on
 - the leak detector has not completed the test cycle
- Optional aluminum bushing retains spout spring and keeps spout from rounding-in: the two leading causes of clicking off and splash-back spillage.
- Nozzle is equipped with a unique Flo-Stop® device that shuts off the nozzle if it falls from the fill neck or raises above the horizontal.
- StreamShaper® reduces turbulence for straighter fuel flow and less splash back spillage.
- Strong flow (up to 75 gpm / 283.9 Lpm)
- Dual poppet design equalizes pressure on both sides of the main poppet valve in order to aid in lifting the lever, and ultimately opening the main poppet valve for full flow.
- Optional cold weather seals are rated to -40 °F/C.
- Optional Gilbarco, Tokheim, and Wayne handguards can be fitted with a magnet to trigger the dispenser's proximity switch, or can be provided without the magnet for dispensers equipped with a standard "flapper" switch.
- Comes standard with smooth full grip guard and 1808 waffle splash guard



MODEL NO.
177610

New High-Flow Diesel PHG Nozzles with NPT Inlet

MODEL NO.	DESCRIPTION	SHIPPING WEIGHT LBS (KG)
177610	with Three Notch Hold Open Clip, Polymer Handguard, 1808 Waffle Splash Guard and Spout Bushing	4.3 (2.0)
177612	without Hold Open Clip, with Polymer Handguard, 1808 Waffle Splash Guard and Spout Bushing	4.2 (1.9)
177681	with Three Notch Hold Open Clip, Polymer Handguard and Spout Bushing, without Waffle Splash Guard	4.3 (2.0)
177690	with Three Notch Hold Open Clip, Polymer Handguard, POPD®S, 1808 Waffle Splash Guard and Spout Bushing	4.3 (2.0)
504010	with Three Notch Hold Open Clip, Polymer Handguard and 1808 Waffle Splash Guard, without Spout Bushing	4.2 (1.9)
504012	without Hold Open Clip and Spout Bushing, with Polymer Handguard and 1808 Waffle Splash Guard	4.2 (1.9)
651910	with Three Notch Hold Open Clip, Polymer Handguard, 1808 Waffle Splash Guard, Spout Bushing and Cold Weather Seals	4.3 (2.0)
651981	with Three Notch Hold Open Clip, Polymer Handguard, Spout Bushing and Cold Weather Seals, without Waffle Splash Guard	4.2 (1.9)
652110	with Three Notch Hold Open Clip, Polymer Handguard, 1808 Waffle Splash Guard and Cold Weather Seals, without Spout Bushing	4.3 (2.0)
1776240	with Single Notch Hold Open Clip, Polymer Handguard, 1808 Waffle Splash Guard and Spout Bushing	4.3 (2.0)
5040132	with Three Notch Hold Open Clip, and Polymer Handguard, without Waffle Splash Guard and Spout Bushing	4.2 (1.9)
6519159	without Hold Open Clip, with Polymer Handguard, 1808 Waffle Splash Guard, Spout Bushing and Cold Weather Seals	4.2 (1.9)
11043132	with Three Notch Hold Open Clip, Polymer Handguard and Short Spout Spring, without Waffle Splash Guard and Spout Bushing	4.2 (1.9)
17761001	with Three Notch Hold Open Clip, Polymer Handguard, 1808 Waffle Splash Guard, 3" Longer Spout and Spout Bushing, without StreamShaper®	4.4 (2.0)
1678110N^	with Three Notch Hold Open Clip, Polymer Handguard, 1808 Waffle Splash Guard, Cold Weather Seals and Spout Bushing	4.6 (2.0)

^ NOT LISTED

New High-Flow Diesel PHG Nozzles with BSP Inlet

MODEL NO.	DESCRIPTION	SHIPPING WEIGHT LBS (KG)
504038	with Three Notch Hold Open Clip, Polymer Handguard and 1808 Waffle Splash Guard, without Spout Bushing	0 4.2 (1.9)

^ NOT LISTED



WARNING: Cancer and Reproductive Harm - www.P65Warnings.ca.gov

VIIIS Nozzles

Pressure Activated, automatic shut-off nozzle for truck stop and other high volume full-service, self-service and unattended stations.

Dimensions

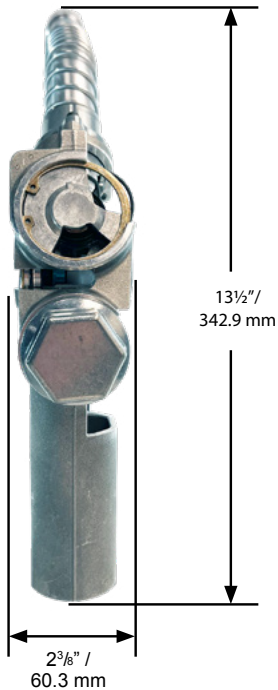
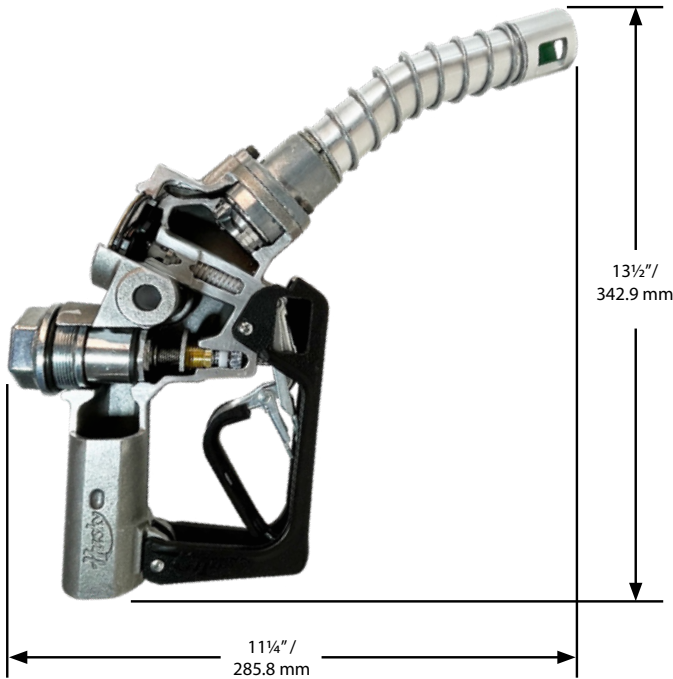

New High-Flow Diesel MHG Nozzles with NPT Inlet

MODEL NO.	DESCRIPTION	SHIPPING WEIGHT LBS (KG)
749610	with Three Notch Hold Open Clip, Metal Handguard, 1808 Waffle Splash Guard and Spout Bushing	4.5 (2.0)
749612	without Hold Open Clip, with Metal Handguard, 1808 Waffle Splash Guard and Spout Bushing	4.4 (2.0)
751010	with Three Notch Hold Open Clip, Metal Handguard and 1808 Waffle Splash Guard, without Spout Bushing	4.4 (2.0)

^ NOT LISTED

Construction

Body	One piece sand cast aluminum with high-impact polymer or metal handguard
Seals	Fluorocarbon
Packing	Double o-ring seal protected by fiber-reinforced Teflon®
Lever	One piece contoured steel with hard polymer lever cover
Inlet	1" (25.4 mm) NPT or 1" (25.4 mm) BSP

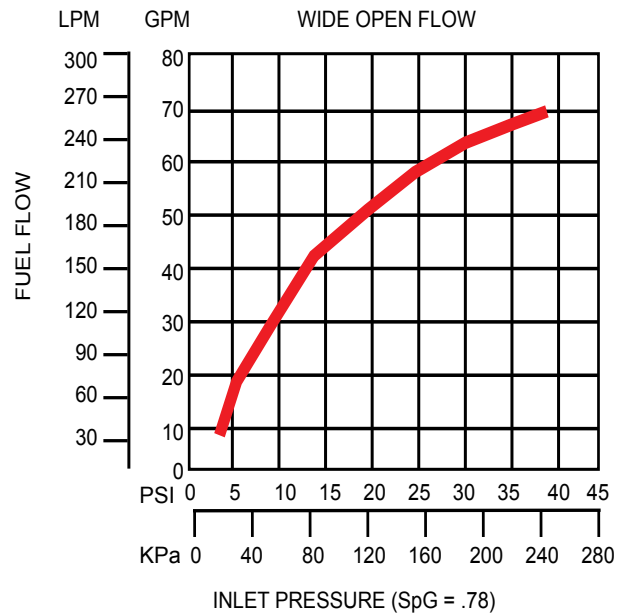

VIIIS Nozzles

Pressure Activated, automatic shut-off nozzle for truck stop and other high volume full-service, self-service and unattended stations.

Nozzle Options

Nozzle Guard Options



Full Grip Guard

POPD®S
Full Grip Guard

POPD®H
Full Grip Guard

Waffle Guard Options



1808 Waffle Guard

Handguard Options



Standard Polymer
Handguard

Standard Metal
Handguard

Gilbarco Polymer
Handguard
(with or without Magnet)

Tokheim Polymer
Handguard
(with or without Magnet)

Wayne Polymer
Handguard
(with or without Magnet)

Lever Options

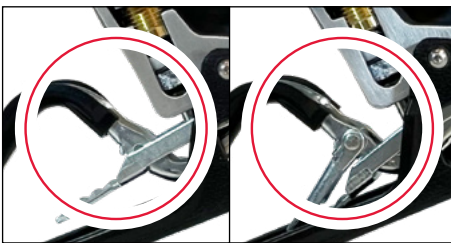

Lever without Hold
Open Clip

Lever with Hold
Open Clip

Latch Plate Options

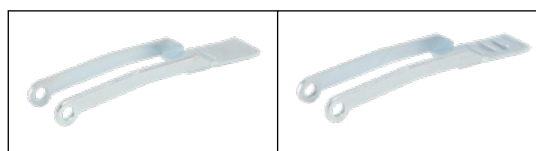

1 - Position Latch Plate

3 - Position Latch Plate

VIIIS Nozzles

Pressure Activated, automatic shut-off nozzle for truck stop and other high volume full-service, self-service and unattended stations.

System Options

Safe-T-Breaks®

MODEL NO.	DESCRIPTION
002276	1" F x 1" F NPT Reconnectable Safe-T-Break®
003076	1" F x 1" F BSPP Reconnectable Safe-T-Break®
003076A	1" F x 1" F BSPP Reconnectable Safe-T-Break® - Atex
005231	1" F x 1" F Low Pull NPT Reconnectable Safe-T-Break®
005812	1" F x 1" F NPT Non-Reconnectable Safe-T-Break®
006301	1" F x 1" F NPT Non-Reconnectable PCC Safe-T-Break®
006914	1" F x 1" F BSPP Non-Reconnectable Safe-T-Break®
008331	1" F x 1" F NPT CK Reconnectable MAGBREAK®
009911	1" F x 1" F BSPP Reconnectable G2 MAGBREAK®

Swivel/Safe-T-Break® Combos

MODEL NO.	DESCRIPTION
005969	1" M NPT Multi-Plane Swivel connected to 1" F NPT Reconnectable Safe-T-Break®
008015	1" M BSPP Multi-Plane Swivel connected to 1" F BSPP Reconnectable Safe-T-Break®
008015A	1" M BSPP Multi-Plane Swivel connected to 1" F BSPP Reconnectable Safe-T-Break® - Atex

Spouts

MODEL NO.	DESCRIPTION
002279	Complete Spout Assembly with Spout Bushing
003589	Complete Long Spout Assembly without Spout Bushing
005017	Complete Spout Assembly without Spout Bushing
007218	Complete Long Spout Assembly with Spout Bushing
011043	Complete Spout Assembly without Spout Bushing, with Small Spout Spring
011129	Complete Long Spout Assembly without Spout Bushing and UL Groove
010434	Unleaded Long Spout with StreamShaper®

Pressure/Vacuum Vents

MODEL NO.	DESCRIPTION
004620	2" Slip-On Pressure Vacuum Vent
004885	2" Thread-On Pressure Vacuum Vent - NPT
005885	2" Thread-On Pressure Vacuum Vent with Internal Screen - NPT

Accessories, Testing and Maintenance

MODEL NO.	DESCRIPTION
003593	Hold Open Clip Kit
006645	Plunger Assembly Lift Tool
007089	Nozzle Service Kit

Swivels

MODEL NO.	DESCRIPTION
000087	1" M x 1" F NPT Multi-Plane Swivel
000095	1" M x 1" F NPT 70° Multi-Plane Swivel
003306	1" M x 1" F BSPP Multi-Plane Swivel
003395	1" M x 1" F NPT Multi-Plane Restricted Swivel
004860	1" M x 1" F NPT Multi-Plane High Volume Swivel
006949	1" M x 1" F BSPP Multi-Plane High Volume Swivel

Guards

MODEL NO.	DESCRIPTION
001808	Waffle Splash Guard
004740	Full Grip Guard
005494	Lever Guard
005516	Full Grip Reguard
006628	POPD® S Clear Cover
007352	POPD® S Full Grip Guard
007999	POPD® H Clear Cover
008167	POPD® S Mate Guard
008168	POPD® H Mate Guard
008177	POPD® EZS Nozzle Guard
008178	POPD® EZH Nozzle Guard
008186	POPD® H Full Grip Guard
008193	POPD® H Full Grip Reguard
008194	POPD® S Full Grip Reguard

Guard Color Chart

COLOR	SUFFIX	COLOR	SUFFIX	COLOR <i>CUSTOM</i>	SUFFIX
Blue	-01	Gold	-08	Amoco Blue	-07 <i>CUSTOM</i>
Red	-02	Silver	-09	Apple Green	-18 <i>CUSTOM</i>
Green	-03	BP Green	-16	Purple	-19 <i>CUSTOM</i>
Black	-04	M Blue	-21	Pink	-20 <i>CUSTOM</i>
Yellow	-05	Orange	-39	BPS Green	-22 <i>CUSTOM</i>
White	-06				

Scuff Guards are to be ordered with the corresponding guard color option added to the model number. Example: If BLUE guards are desired, add guard color option -01 to the model number (159504-01). For custom colors, a minimum order of 4,000 guards will be required.

VIII Nozzles

Automatic shut-off nozzle for truck stop and other high volume full-service, self-service and unattended stations.

- VIII nozzle shuts off when the gas tank is full.
- Optional aluminum bushing retains spout spring and keeps spout from rounding-in: the two leading causes of clicking off and splash-back spillage.
- Nozzle is equipped with a unique Flo-Stop® device that shuts off the nozzle if it falls from the fill neck or raises above the horizontal.
- *StreamShaper*® reduces turbulence for straighter fuel flow and less splash back spillage.
- Strong flow (up to 75 gpm / 283.9 Lpm)
- Dual poppet design equalizes pressure on both sides of the main poppet valve in order to aid in lifting the lever, and ultimately opening the main poppet valve for full flow.
- Optional cold weather seals are rated to -40 °F/C.
- Optional Gilbarco, Tokheim, and Wayne handguards can be fitted with a magnet to trigger the dispenser's proximity switch, or can be provided without the magnet for dispensers equipped with a standard "flapper" switch.
- Comes standard with smooth full grip guard and 1808 waffle splash guard



MODEL NO.
173312

New High-Flow Diesel PHG Nozzles with NPT Inlet

MODEL NO.	DESCRIPTION	SHIPPING WEIGHT LBS (KG)
173312	without Hold Open Clip, with Polymer Handguard, 1808 Waffle Splash Guard and Spout Bushing	4.3 (2.0)
503012	without Hold Open Clip and Spout Bushing, with Polymer Handguard and 1808 Waffle Splash Guard	4.2 (1.9)
651512	without Hold Open Clip, with Polymer Handguard, 1808 Waffle Splash Guard, Spout Bushing and Cold Weather Seals	4.3 (2.0)
173310N [^]	with Three Notch Hold Open Clip, Polymer Handguard, 1808 Waffle Splash Guard and Spout Bushing	4.3 (2.0)
173310NR [^]	with Three Notch Hold Open Clip, Polymer Handguard, 1808 Waffle Splash Guard and Spout Bushing - in Retail Packaging	4.2 (1.9)
173381N [^]	with Three Notch Hold Open Clip, Polymer Handguard and Spout Bushing, without Waffle Splash Guard	4.2 (1.9)
503010N [^]	with Three Notch Hold Open Clip, Polymer Handguard and 1808 Waffle Splash Guard, without Spout Bushing	4.2 (1.9)
503081N [^]	with Three Notch Hold Open Clip and Polymer Handguard, without Waffle Splash Guard and Spout Bushing	4.1 (1.9)
651510N [^]	with Three Notch Hold Open Clip, Polymer Handguard, 1808 Waffle Splash Guard and Cold Weather Seals, without Spout Bushing	4.3 (2.0)
17331001N [^]	with Three Notch Hold Open Clip, Polymer Handguard, 1808 Waffle Splash Guard and 3" Longer Spout, without StreamShaper®	4.4 (2.0)
1679710N [^]	with Three Notch Hold Open Clip, Polymer Handguard, 1808 Waffle Splash Guard and Cold Weather Seals and Spout Bushing	4.4 (2.0)

[^] NOT LISTED

New High-Flow Diesel PHG Nozzles with BSP Inlet

MODEL NO.	DESCRIPTION	SHIPPING WEIGHT LBS (KG)
173338N [^]	with Three Notch Hold Open Clip, Polymer Handguard, 1808 Waffle Splash Guard and Spout Bushing	4.3 (2.0)
503038N [^]	with Three Notch Hold Open Clip, Polymer Handguard and 1808 Waffle Splash Guard, without Spout Bushing	4.2 (1.9)
1058538N [^]	with Three Notch Hold Open Clip, Polymer Handguard and 1808 Waffle Splash Guard, without Spout Bushing and UL Spout Groove	4.2 (1.9)
13705213N [^]	with Three Notch Hold Open Clip and Tokheim Magnetic Handguard, without Waffle Splash Guard and Spout Bushing	4.1 (1.9)
105853801N [^]	with Three Notch Hold Open Clip, Polymer Handguard, 1808 Waffle Splash Guard and 3" Longer Spout, without StreamShaper®, Spout Bushing and UL Spout Groove	4.4 (2.0)

[^] NOT LISTED



WARNING: Cancer and Reproductive Harm - www.P65Warnings.ca.gov

VIII Nozzles

Automatic shut-off nozzle for truck stop and other high volume full-service, self-service and unattended stations.

Dimensions

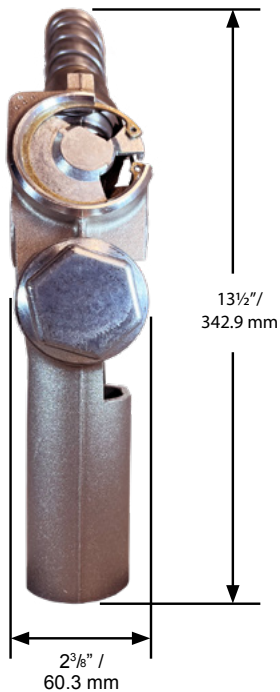
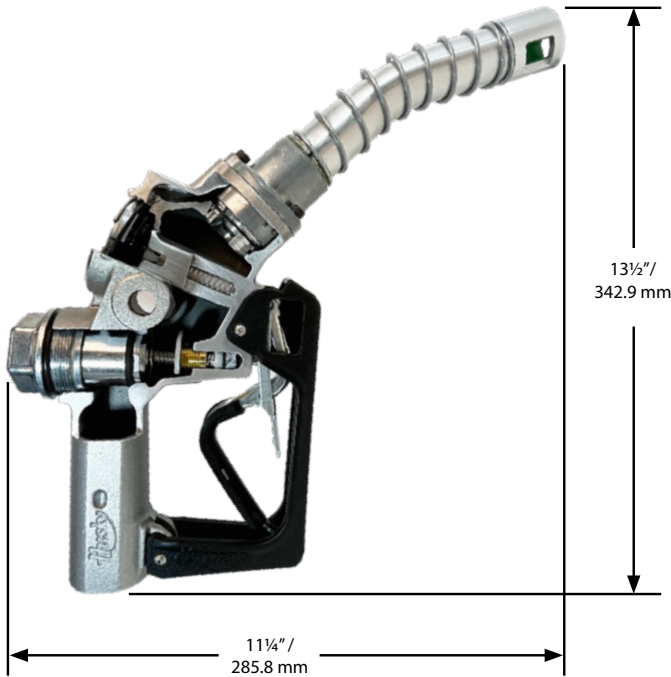

New High-Flow Diesel MHG Nozzles with NPT Inlet

MODEL NO.	DESCRIPTION	SHIPPING WEIGHT LBS (KG)
749312	without Hold Open Clip, with Polymer Handguard, 1808 Waffle Splash Guard and Spout Bushing	4.5 (2.0)
750612	without Hold Open Clip and Spout Bushing, with Metal Handguard and 1808 Waffle Splash Guard	4.4 (2.0)
749310N [^]	with Three Notch Hold Open Clip, Metal Handguard, 1808 Waffle Splash Guard and Spout Bushing	4.5 (2.0)
750610N [^]	with Three Notch Hold Open Clip, Metal Handguard and 1808 Waffle Splash Guard, without Spout Bushing	4.4 (2.0)
751510N [^]	with Three Notch Hold Open Clip, Metal Handguard, 1808 Waffle Splash Guard, Spout Bushing and Cold Weather Seals	4.5 (2.0)
7506230N [^]	with Three Notch Hold Open Clip, Metal Handguard, 1808 Waffle Splash Guard and Short Spout Spring, without Spout Bushing	4.4 (2.0)
750623001N [^]	with Three Notch Hold Open Clip, Metal Handguard, 1808 Waffle Splash Guard, 3" Longer Spout and Short Spout Spring, without StreamShaper [®] and Spout Bushing	4.5 (2.0)

[^] NOT LISTED

New High-Flow Diesel MHG Nozzles with BSP Inlet

MODEL NO.	DESCRIPTION	SHIPPING WEIGHT LBS (KG)
749338N [^]	with Three Notch Hold Open Clip, Metal Handguard, 1808 Waffle Splash Guard and Spout Bushing	4.5 (2.0)

[^] NOT LISTED

Construction

Body	One piece sand cast aluminum with high-impact polymer or metal handguard
Seals	Fluorocarbon
Packing	Double o-ring seal protected by fiber-reinforced Teflon [®]
Lever	One piece contoured steel with hard polymer lever cover
Inlet	1" (25.4 mm) NPT or 1" (25.4 mm) BSP

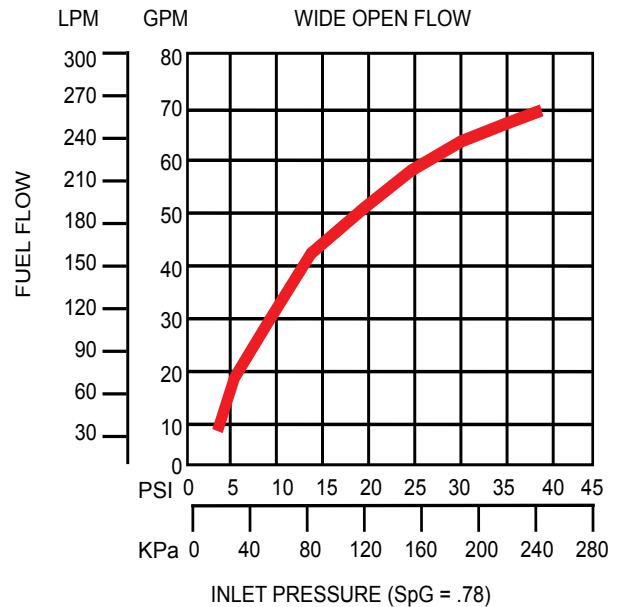

VIII Nozzles



TRUCK AND HIGH VOLUME

Automatic shut-off nozzle for truck stop and other high volume full-service, self-service and unattended stations.

Nozzle Options

Nozzle Guard Options



Full Grip Guard

POPD®S
Full Grip Guard

POPD®H
Full Grip Guard

Waffle Guard Options

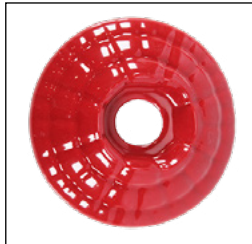

1808 Waffle Guard

Handguard Options



Standard Polymer
Handguard

Standard Metal
Handguard

Gilbarco Polymer
Handguard
(with or without Magnet)

Tokheim Polymer
Handguard
(with or without Magnet)

Wayne Polymer
Handguard
(with or without Magnet)

Lever Options

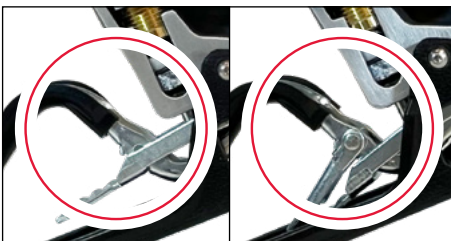

Lever without Hold
Open Clip

Lever with Hold
Open Clip

Latch Plate Options

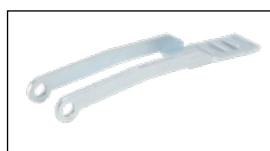

3 - Position Latch Plate

VIII Nozzles

Automatic shut-off nozzle for truck stop and other high volume full-service, self-service and unattended stations.

System Options

Safe-T-Breaks®

MODEL NO.	DESCRIPTION
002276	1" F x 1" F NPT Reconnectable Safe-T-Break®
003076	1" F x 1" F BSPP Reconnectable Safe-T-Break®
003076A	1" F x 1" F BSPP Reconnectable Safe-T-Break® - Atex
005231	1" F x 1" F Low Pull NPT Reconnectable Safe-T-Break®
005812	1" F x 1" F NPT Non-Reconnectable Safe-T-Break®
006301	1" F x 1" F NPT Non-Reconnectable PCC Safe-T-Break®
006914	1" F x 1" F BSPP Non-Reconnectable Safe-T-Break®
008331	1" F x 1" F NPT CK Reconnectable MAGBREAK®
009911	1" F x 1" F BSPP Reconnectable G2 MAGBREAK®

Swivel/Safe-T-Break® Combos

MODEL NO.	DESCRIPTION
005969	1" M NPT Multi-Plane Swivel connected to 1" F NPT Reconnectable Safe-T-Break®
008015	1" M BSPP Multi-Plane Swivel connected to 1" F BSPP Reconnectable Safe-T-Break®
008015A	1" M BSPP Multi-Plane Swivel connected to 1" F BSPP Reconnectable Safe-T-Break® - Atex

Spouts

MODEL NO.	DESCRIPTION
002279	Complete Spout Assembly with Spout Bushing
003589	Complete Long Spout Assembly without Spout Bushing
005017	Complete Spout Assembly without Spout Bushing
007218	Complete Long Spout Assembly with Spout Bushing
011043	Complete Spout Assembly without Spout Bushing, with Small Spout Spring
011129	Complete Long Spout Assembly without Spout Bushing and UL Groove
010434	Unleaded Long Spout with StreamShaper®

Pressure/Vacuum Vents

MODEL NO.	DESCRIPTION
004620	2" Slip-On Pressure Vacuum Vent
004885	2" Thread-On Pressure Vacuum Vent - NPT
005885	2" Thread-On Pressure Vacuum Vent with Internal Screen - NPT

Accessories, Testing and Maintenance

MODEL NO.	DESCRIPTION
003593	Hold Open Clip Kit
006645	Plunger Assembly Lift Tool
007089	Nozzle Service Kit

Swivels

MODEL NO.	DESCRIPTION
000087	1" M x 1" F NPT Multi-Plane Swivel
000095	1" M x 1" F NPT 70° Multi-Plane Swivel
003306	1" M x 1" F BSPP Multi-Plane Swivel
003395	1" M x 1" F NPT Multi-Plane Restricted Swivel
004860	1" M x 1" F NPT Multi-Plane High Volume Swivel
006949	1" M x 1" F BSPP Multi-Plane High Volume Swivel

Guards

MODEL NO.	DESCRIPTION
001808	Waffle Splash Guard
004740	Full Grip Guard
005494	Lever Guard
005516	Full Grip Reguard
006628	POPD® S Clear Cover
007352	POPD® S Full Grip Guard
007999	POPD® H Clear Cover
008167	POPD® S Mate Guard
008168	POPD® H Mate Guard
008177	POPD® EZS Nozzle Guard
008178	POPD® EZH Nozzle Guard
008186	POPD® H Full Grip Guard
008193	POPD® H Full Grip Reguard
008194	POPD® S Full Grip Reguard

Guard Color Chart

COLOR	SUFFIX	COLOR	SUFFIX	COLOR <i>CUSTOM</i>	SUFFIX
Blue	-01	Gold	-08	Amoco Blue	-07 <i>CUSTOM</i>
Red	-02	Silver	-09	Apple Green	-18 <i>CUSTOM</i>
Green	-03	BP Green	-16	Purple	-19 <i>CUSTOM</i>
Black	-04	M Blue	-21	Pink	-20 <i>CUSTOM</i>
Yellow	-05	Orange	-39	BPS Green	-22 <i>CUSTOM</i>
White	-06				

Scuff Guards are to be ordered with the corresponding guard color option added to the model number. Example: If BLUE guards are desired, add guard color option -01 to the model number (159504-01). For custom colors, a minimum order of 4,000 guards will be required.

1HS Nozzles

Automatic shut-off nozzle with polymer handguard for dispensing up to 25 gpm / 94.6 Lpm.

- 1HS nozzle shuts off when the gas tank is full.
- Nozzle is equipped with a unique Flo-Stop® device that shuts off the nozzle if it falls from the fill neck or raises above the horizontal.
- Optional cold weather seals are rated to -40 °F/C.
- Optional Gilbarco, Tokheim, and Wayne handguards can be fitted with a magnet to trigger the dispenser's proximity switch, or can be provided without the magnet for dispensers equipped with a standard "flapper" switch.
- Comes standard with smooth full grip guard
- ADA-compliant EZ Lever reduces the force required to open the main poppet valve by 50%, resulting in a lever operating force ≤5 lbs.



MODEL NO.
026812

New Heavy Duty Diesel PHG Nozzles with NPT Inlet

MODEL NO.	DESCRIPTION	SHIPPING WEIGHT LBS (KG)
026812	without Hold Open Clip, with Polymer Handguard	3.4 (1.5)
026810N^	with Two Notch Hold Open Clip and Polymer Handguard	3.4 (1.5)
026865N^	with Two Notch Hold Open Clip, Polymer Handguard and 1808 Waffle Splash Guard	3.5 (1.6)
E1522610N^	with Two Notch Hold Open Clip, Mate Guard and Wayne Magnetic Handguard	3.5 (1.6)

^ NOT LISTED

New Heavy Duty Diesel PHG Nozzles with BSP Inlet

MODEL NO.	DESCRIPTION	SHIPPING WEIGHT LBS (KG)
-026838A	with Two Notch Hold Open Clip and Polymer Handguard	3.4 (1.5)
026838N^	with Two Notch Hold Open Clip and Polymer Handguard	3.4 (1.5)
-E1522638A	with Two Notch Hold Open Clip, Tilt Poppet, Wayne Magnetic Handguard, Mate Guard and Polymer Handle	3.5 (1.6)

^ NOT LISTED



II 1 G
EN 13012
TYPE 2

WARNING: Cancer and Reproductive Harm - www.P65Warnings.ca.gov

1HS Nozzles

Automatic shut-off nozzle with polymer handguard for dispensing up to 25 gpm / 94.6 Lpm.

Dimensions

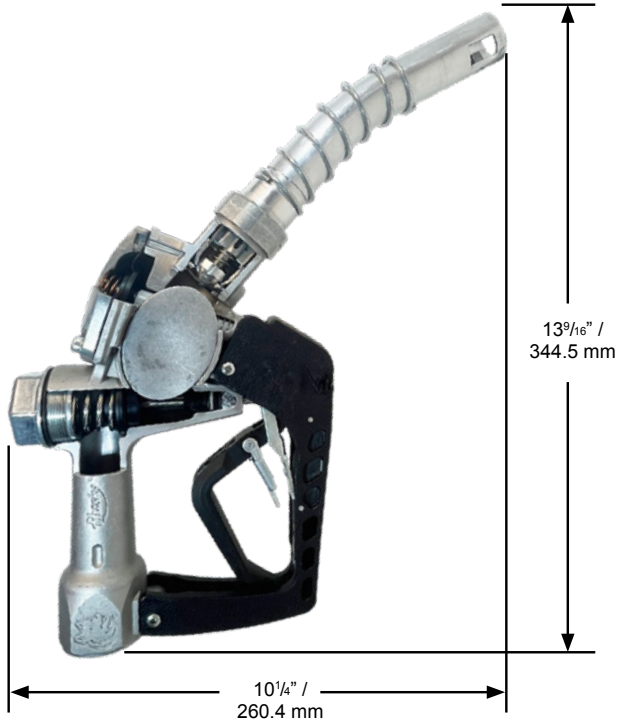

New Heavy Duty Diesel MHG Nozzles with NPT Inlet

MODEL NO.	DESCRIPTION	SHIPPING WEIGHT LBS (KG)
696310N [^]	with Two Notch Hold Open Clip and Metal Handguard	3.6 (1.6)
696365N [^]	with Two Notch Hold Open Clip, Metal Handguard and 1808 Waffle Splash Guard	3.7 (1.7)

[^] NOT LISTED

New Heavy Duty Diesel MHG Nozzles with BSP Inlet

MODEL NO.	DESCRIPTION	SHIPPING WEIGHT LBS (KG)
696338N [^]	with Two Notch Hold Open Clip and Metal Handguard	3.6 (1.6)

[^] NOT LISTED

Construction

Body	One piece die cast aluminum with high-impact polymer or metal handguard
Seals	Fluorocarbon
Packing	Double o-ring seal protected by fiber-reinforced Teflon [®]
Lever	Two-piece polymer EZ Lever
Inlet	1" (25.4 mm) NPT or 1" (25.4 mm) BSP

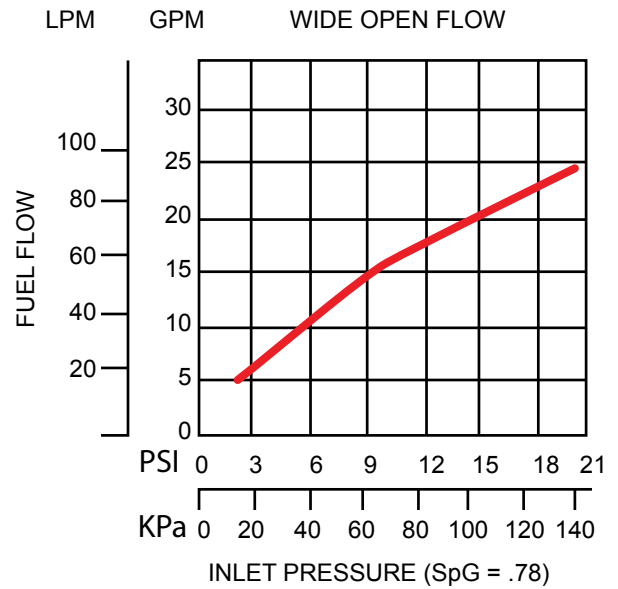

1HS Nozzles

TRUCK AND HIGH VOLUME

Automatic shut-off nozzle with polymer handguard for dispensing up to 25 gpm / 94.6 Lpm.

Nozzle Options

Nozzle Guard Options



Waffle Guard Options



Handguard Options

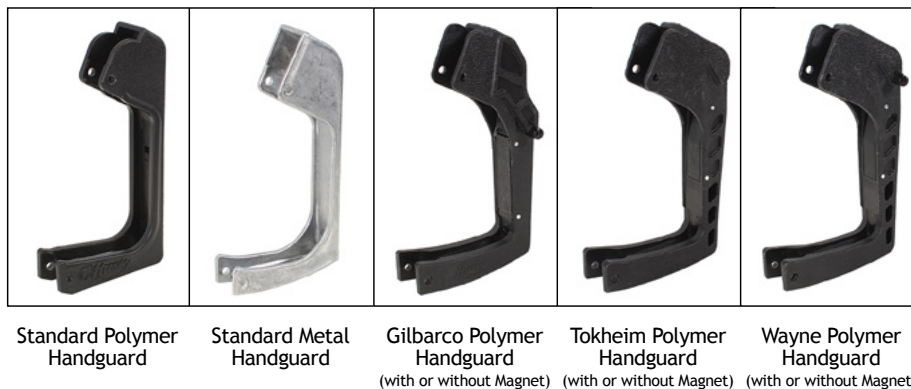

Lever Options

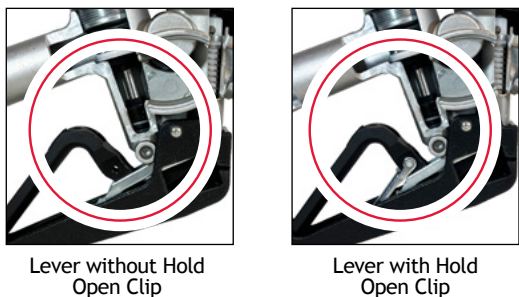

Latch Plate Options

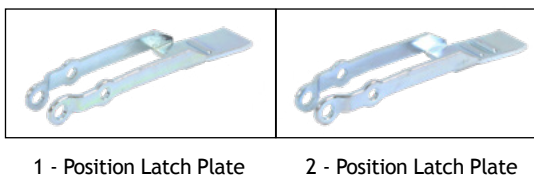

1HS Nozzles

Automatic shut-off nozzle with polymer handguard for dispensing up to 25 gpm / 94.6 Lpm.

System Options

Safe-T-Breaks®

MODEL NO.	DESCRIPTION
002276	1" F x 1" F NPT Reconnectable Safe-T-Break®
003076	1" F x 1" F BSPP Reconnectable Safe-T-Break®
003076A	1" F x 1" F BSPP Reconnectable Safe-T-Break® - Atex
005231	1" F x 1" F Low Pull NPT Reconnectable Safe-T-Break®
005812	1" F x 1" F NPT Non-Reconnectable Safe-T-Break®
006301	1" F x 1" F NPT Non-Reconnectable PCC Safe-T-Break®
006914	1" F x 1" F BSPP Non-Reconnectable Safe-T-Break®
008331	1" F x 1" F NPT CK Reconnectable MAGBREAK®
009911	1" F x 1" F BSPP Reconnectable G2 MAGBREAK®

Swivel/Safe-T-Break® Combos

MODEL NO.	DESCRIPTION
005969	1" M NPT Multi-Plane Swivel connected to 1" F NPT Reconnectable Safe-T-Break®
008015	1" M BSPP Multi-Plane Swivel connected to 1" F BSPP Reconnectable Safe-T-Break®
008015A	1" M BSPP Multi-Plane Swivel connected to 1" F BSPP Reconnectable Safe-T-Break® - Atex Spouts

Spouts

MODEL NO.	DESCRIPTION
005215	Heavy Duty Diesel Spout

Pressure/Vacuum Vents

MODEL NO.	DESCRIPTION
004620	2" Slip-On Pressure Vacuum Vent
004885	2" Thread-On Pressure Vacuum Vent - NPT
005885	2" Thread-On Pressure Vacuum Vent with Internal Screen - NPT

Accessories, Testing and Maintenance

MODEL NO.	DESCRIPTION
000385	1" M x 3/4" F Reducer Bushing
000397	Unleaded Spout Gauge
003593	Hold Open Clip Kit
007089	Nozzle Service Kit

Swivels

MODEL NO.	DESCRIPTION
000087	1" M x 1" F NPT Multi-Plane Swivel
000095	1" M x 1" F NPT 70° Multi-Plane Swivel
000352	1" M x 3/4" F NPT Multi-Plane Swivel
000356	1" M x 3/4" F NPT Multi-Plane Swivel Anodized Black
003306	1" M x 1" F BSPP Multi-Plane Swivel
003306A	1" M x 1" F BSPP Multi-Plane Swivel - Atex
003395	1" M x 1" F NPT Multi-Plane Restricted Swivel
004860	1" M x 1" F NPT Multi-Plane High Volume Swivel
006949	1" M x 1" F BSPP Multi-Plane High Volume Swivel

Guards

MODEL NO.	DESCRIPTION
000099	Protection Package
000226	Mate Nozzle Guard
000554	Full Grip Guard
001804	Full Grip Reguard
001808	Waffle Splash Guard
001811	Reguard Protection Package
005494	Lever Guard
006628	POPD® S Clear Cover
006655	POPD® S Full Grip Guard
007210	POPD® S Full Grip Reguard
007295	Mate Handle Guard
007999	POPD® H Clear Cover
008169	POPD® S Mate Nozzle Guard
008170	POPD® H Mate Nozzle Guard
008179	POPD® EZS Nozzle Guard
008180	POPD® EZH Nozzle Guard
008183	POPD® H Full Grip Guard
008190	POPD® H Full Grip Reguard

Guard Color Chart

COLOR	SUFFIX	COLOR	SUFFIX	COLOR <i>CUSTOM</i>	SUFFIX
Blue	-01	Gold	-08	Amoco Blue	-07 <i>CUSTOM</i>
Red	-02	Silver	-09	Apple Green	-18 <i>CUSTOM</i>
Green	-03	BP Green	-16	Purple	-19 <i>CUSTOM</i>
Black	-04	M Blue	-21	Pink	-20 <i>CUSTOM</i>
Yellow	-05	Orange	-39	BPS Green	-22 <i>CUSTOM</i>
White	-06				

Scuff Guards are to be ordered with the corresponding guard color option added to the model number. Example: If BLUE guards are desired, add guard color option -01 to the model number (159504-01). For custom colors, a minimum order of 4,000 guards will be required.

1HSS Nozzles

Automatic shut-off nozzle with polymer handguard for dispensing up to 25 gpm / 94.6 Lpm.

- 1HSS nozzle shuts off when:
 - the pump shuts off
 - the gas tank is full
 - the lever is opened before the pump is turned on
 - the leak detector has not completed the test cycle
- Comes standard with smooth full grip guard
- ADA-compliant EZ Lever reduces the force required to open the main poppet valve by 50%, resulting in a lever operating force ≤5 lbs.
- Nozzle is equipped with a unique Flo-Stop® device that shuts off the nozzle if it falls from the fill neck or raises above the horizontal.
- Optional cold weather seals are rated to -40 °F/C.
- Optional Gilbarco, Tokheim, and Wayne handguards can be fitted with a magnet to trigger the dispenser's proximity switch, or can be provided without the magnet for dispensers equipped with a standard "flapper" switch.



MODEL NO.
1217110

New Heavy Duty Diesel PHG Nozzles with NPT Inlet

MODEL NO.	DESCRIPTION	SHIPPING WEIGHT LBS (KG)
1217110	with Two Notch Hold Open Clip and Polymer Handguard	3.4 (1.5)
1217110N^	with Two Notch Hold Open Clip and Polymer Handguard	3.4 (1.5)
12171266	with Two Notch Hold Open Clip, Waffle Guard, Inlet Screen (Strainer) and Polymer Handguard	3.4 (1.5)

New Heavy Duty Diesel PHG Nozzles with BSP Inlet

MODEL NO.	DESCRIPTION	SHIPPING WEIGHT LBS (KG)
1217138N^	with Two Notch Hold Open Clip and Polymer Handguard	3.4 (1.5)
1217138	with Two Notch Hold Open Clip and Polymer Handguard	3.4 (1.5)

New Heavy Duty Diesel PHG Nozzles with BSP Inlet

MODEL NO.	DESCRIPTION	SHIPPING WEIGHT LBS (KG)
1217410	with Two Notch Hold Open Clip and Metal Handguard	3.5 (1.6)

^ NOT LISTED



II 1 G
EN 13012
TYPE 2



WARNING: Cancer and Reproductive Harm - www.P65Warnings.ca.gov

1HSS Nozzles

Automatic shut-off nozzle with polymer handguard for dispensing up to 25 gpm / 94.6 Lpm.

Dimensions

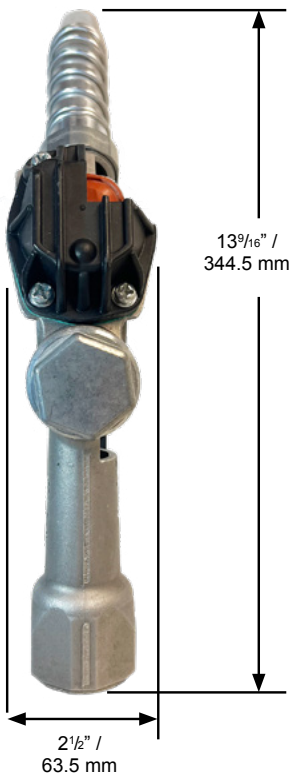
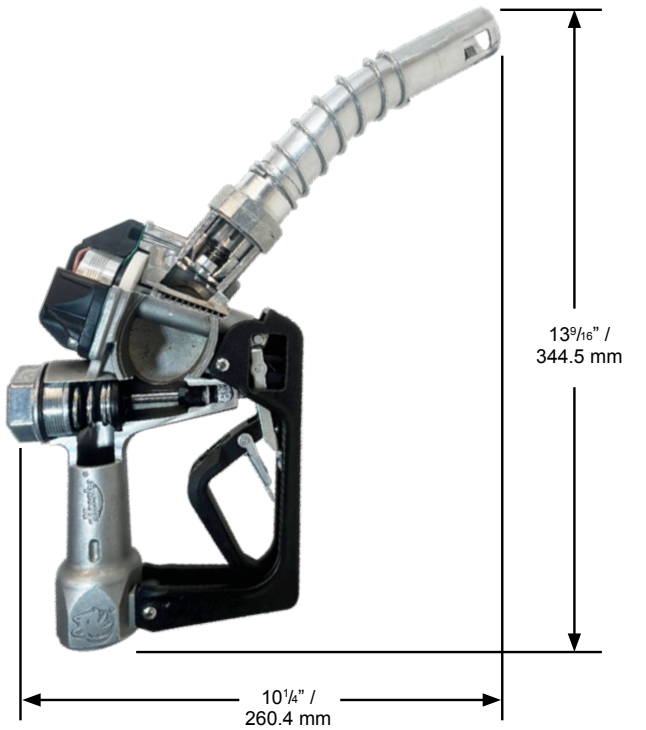

Construction

Body	One piece die cast aluminum with high-impact polymer or metal handguard
Seals	Fluorocarbon
Packing	Double o-ring seal protected by fiber-reinforced Teflon®
Lever	Two-piece polymer EZ Lever
Inlet	1" (25.4 mm) NPT or 1" (25.4 mm) BSP

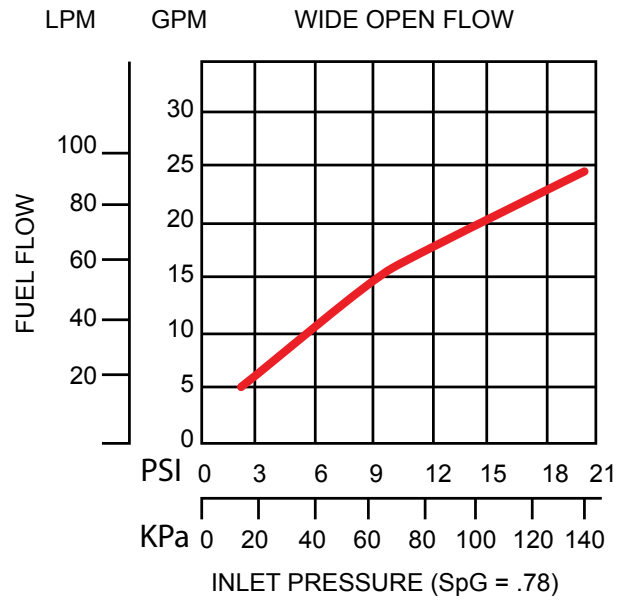

1HSS Nozzles

TRUCK AND HIGH VOLUME

Automatic shut-off nozzle with polymer handguard for dispensing up to 25 gpm / 94.6 Lpm.

Nozzle Options

Nozzle Guard Options



Full Grip Guard

POPD®S Full Grip Guard

POPD®H Full Grip Guard

Mate Guard

POPD®S Mate Guard

POPD®H Mate Guard

Waffle Guard Options

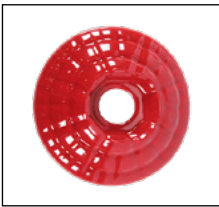

1808 Waffle Guard

Handguard Options



Standard Polymer Handguard

Standard Metal Handguard

Gilbarco Polymer Handguard
(with or without Magnet)

Tokheim Polymer Handguard
(with or without Magnet)

Wayne Polymer Handguard
(with or without Magnet)

Lever Options



Lever without Hold Open Clip



Lever with Hold Open Clip

Latch Plate Options

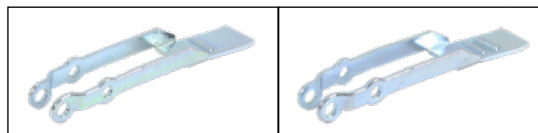

1 - Position Latch Plate

2 - Position Latch Plate

1HSS Nozzles

Automatic shut-off nozzle with polymer handguard for dispensing up to 25 gpm / 94.6 Lpm.

System Options

Safe-T-Breaks®

MODEL NO.	DESCRIPTION
002276	1" F x 1" F NPT Reconnectable Safe-T-Break®
003076	1" F x 1" F BSPP Reconnectable Safe-T-Break®
003076A	1" F x 1" F BSPP Reconnectable Safe-T-Break® - Atex
005231	1" F x 1" F Low Pull NPT Reconnectable Safe-T-Break®
005812	1" F x 1" F NPT Non-Reconnectable Safe-T-Break®
006301	1" F x 1" F NPT Non-Reconnectable PCC Safe-T-Break®
006914	1" F x 1" F BSPP Non-Reconnectable Safe-T-Break®
008331	1" F x 1" F NPT CK Reconnectable MAGBREAK®
009911	1" F x 1" F BSPP Reconnectable G2 MAGBREAK®

Swivel/Safe-T-Break® Combos

MODEL NO.	DESCRIPTION
005969	1" M NPT Multi-Plane Swivel connected to 1" F NPT Reconnectable Safe-T-Break®
008015	1" M BSPP Multi-Plane Swivel connected to 1" F BSPP Reconnectable Safe-T-Break®
008015A	1" M BSPP Multi-Plane Swivel connected to 1" F BSPP Reconnectable Safe-T-Break® - Atex Spouts

Spouts

MODEL NO.	DESCRIPTION
005215	Heavy Duty Diesel Spout

Pressure/Vacuum Vents

MODEL NO.	DESCRIPTION
004620	2" Slip-On Pressure Vacuum Vent
004885	2" Thread-On Pressure Vacuum Vent - NPT
005885	2" Thread-On Pressure Vacuum Vent with Internal Screen - NPT

Accessories, Testing and Maintenance

MODEL NO.	DESCRIPTION
000385	1" M x 3/4" F Reducer Bushing
003593	Hold Open Clip Kit
007089	Nozzle Service Kit

Swivels

MODEL NO.	DESCRIPTION
000087	1" M x 1" F NPT Multi-Plane Swivel
000095	1" M x 1" F NPT 70° Multi-Plane Swivel
000352	1" M x 3/4" F NPT Multi-Plane Swivel
000356	1" M x 3/4" F NPT Multi-Plane Swivel Anodized Black
003306	1" M x 1" F BSPP Multi-Plane Swivel
003306A	1" M x 1" F BSPP Multi-Plane Swivel - Atex
003395	1" M x 1" F NPT Multi-Plane Restricted Swivel
004860	1" M x 1" F NPT Multi-Plane High Volume Swivel
006949	1" M x 1" F BSPP Multi-Plane High Volume Swivel

Guards

MODEL NO.	DESCRIPTION
001807	Waffle Splash Guard with Smaller Hole
001808	Waffle Splash Guard
005494	Lever Guard
007295	Mate Handle Guard
012164	Full Grip Guard

Guard Color Chart

COLOR	SUFFIX	COLOR	SUFFIX	COLOR <i>CUSTOM</i>	SUFFIX
Blue	-01	Gold	-08	Amoco Blue	-07 <i>CUSTOM</i>
Red	-02	Silver	-09	Apple Green	-18 <i>CUSTOM</i>
Green	-03	BP Green	-16	Purple	-19 <i>CUSTOM</i>
Black	-04	M Blue	-21	Pink	-20 <i>CUSTOM</i>
Yellow	-05	Orange	-39	BPS Green	-22 <i>CUSTOM</i>
White	-06				

Scuff Guards are to be ordered with the corresponding guard color option added to the model number. Example: If BLUE guards are desired, add guard color option -01 to the model number (159504-01). For custom colors, a minimum order of 4,000 guards will be required.

1690/1691 Nozzles

Automatic shut-off bulk fueling nozzle.

- Designed with extra large hand opening to accommodate gloves or mittens
- Equipped with dual poppets for easy opening
- Design includes a self-adjusting stem packing.
- Check valve is in the nozzle body, not the spout, which makes for an inexpensive and fast spout replacement.
- 1690 nozzle is equipped with two-position hold open latch.
- 1691 nozzle is not equipped with a hold open latch.
- Right angle design allows nozzle to “fit” close to walls and corners.
- Cast-in protective standoffs provide durability with rough usage.
- Nozzle is 30% lighter than similar nozzles in the market.

New High Volume Nozzles with NPT Inlet

MODEL NO.	DESCRIPTION	SHIPPING WEIGHT LBS (KG)
169112	without Hold Open Pins, with Shear Groove in Spout	4.6 (2.0)
169010N [^]	with Two-Position Hold Open Pins	4.6 (2.0)
652310N [^]	with Two-Position Hold Open Pins and Cold Weather Seals	4.6 (2.0)

[^] NOT LISTED

New High Volume Nozzles with BSP Inlet

MODEL NO.	DESCRIPTION	SHIPPING WEIGHT LBS (KG)
169038N [^]	with Two-Position Hold Open Pins	4.6 (2.0)

[^] NOT LISTED



MODEL NO.
169010N



WARNING: Cancer and Reproductive Harm - www.P65Warnings.ca.gov

1690/1691 Nozzles

Automatic shut-off bulk fueling nozzle.

Dimensions



Construction

Body	One piece sand cast aluminum
Seals	Fluorocarbon
Packing	Double o-ring seal protected by fiber-reinforced Teflon®
Lever	One piece contoured steel
Inlet	1-1/2" (38.1 mm) NPT or 1-1/2" (38.1 mm) BSP

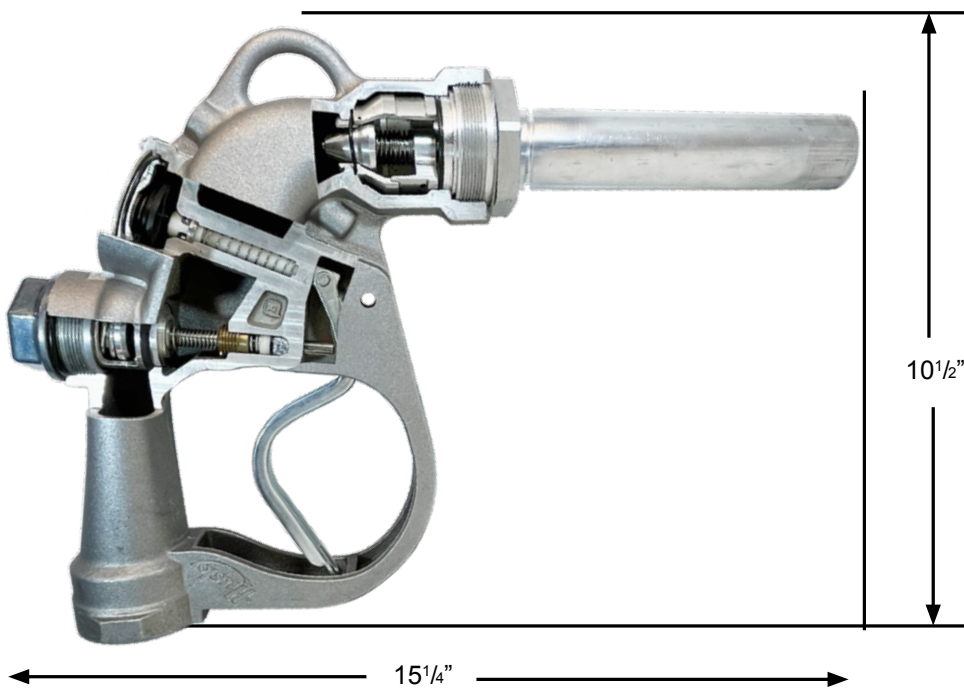
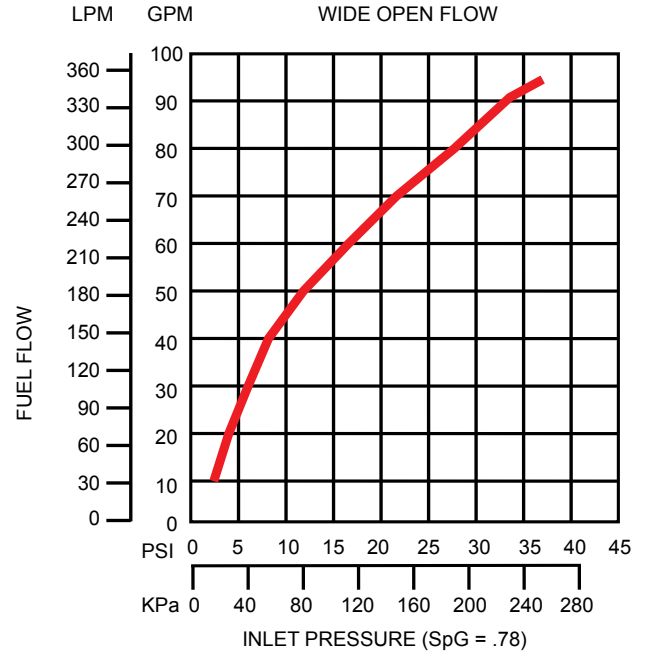

1690/1691 **Nozzles**

Automatic shut-off bulk fueling nozzle.

Nozzle Options

Hold Open Latch Pin Options

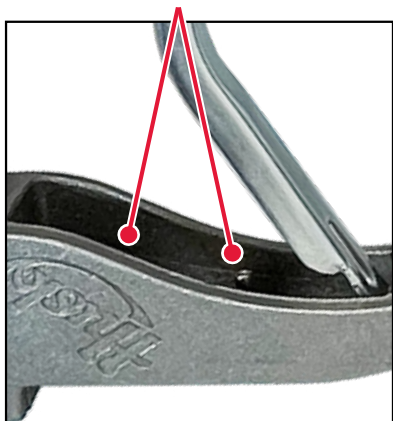

With Hold Open Latch Pins



Without Hold Open Latch Pins

UL Shear Groove Option

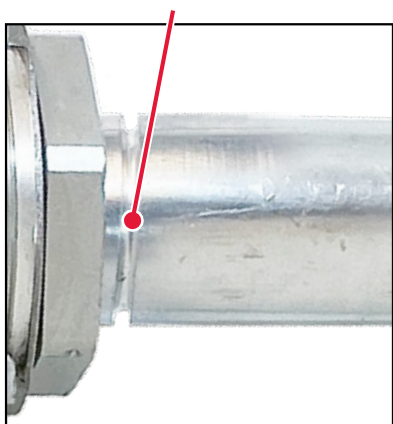

With UL Spout Shear Groove

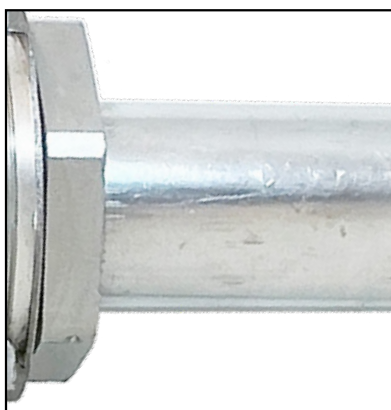

Without UL Spout Shear Groove

1690/1691 Nozzles

Automatic shut-off bulk fueling nozzle.

System Options

Spouts

MODEL NO.	DESCRIPTION
004889	Spout Assembly without Shear Groove
005042	Spout Assembly with shear groove (1691 CUL model)

Pressure/Vacuum Vents

MODEL NO.	DESCRIPTION
004620	2" Slip-On Pressure Vacuum Vent
004885	2" Thread-On Pressure Vacuum Vent - NPT
005885	2" Thread-On Pressure Vacuum Vent with Internal Screen - NPT

Accessories, Testing and Maintenance

MODEL NO.	DESCRIPTION
007089	Nozzle Service Kit

Swivels

MODEL NO.	DESCRIPTION
005240	1-1/4" F x 1-1/2" M NPT Single Plane Swivel
005266	1-1/2" F x 1-1/2" M NPT Single Plane Swivel
005754	1-1/4" F x 1-1/2" M BSPP Single Plane Swivel
005755	1-1/2" F x 1-1/2" M BSPP Single Plane Swivel



Farm & Commercial Nozzles

XFS® Nozzles

Automatic shut-off nozzle for farm, 12V skid tanks and consumer pump applications.

- XFS® nozzle shuts off when the gas tank is full.
- Stainless steel reinforced unleaded spout bushing keeps spout tip round, and acts as a captive fastener to prevent tip-end sensor damage.
- Nozzle is equipped with a unique Flo-Stop® device that shuts off the nozzle if it falls from the fill neck or raises above the horizontal.
- Unleaded *StreamShaper*® reduces turbulence for straighter fuel flow and less splash back spillage.
- Strong flow (up to 18 gpm / 68.1 Lpm)
- Dispenses 10 gpm / 37.8 Lpm at only 5.6 psi / 0.38 bar (unleaded nozzle)
- Has built-in hook and fits “holster lock” of skid tank pumps
- Optional cold weather seals are rated to -40° F/C.
- Comes standard with smooth full grip guard
- Not for use with gravity tanks
- Not legal for retail dispensing applications



MODEL NO.
337008

New Unleaded Nozzles with NPT Inlet

MODEL NO.	DESCRIPTION	SHIPPING WEIGHT LBS (KG)
337008	without Hold Open Clip	3.0 (1.4)
337004N^	with Single Notch Hold Open Clip	3.0 (1.4)
337004NR^	with Single Notch Hold Open Clip - in Retail Packaging	3.0 (1.4)
503404N^	with Single Notch Hold Open Clip, without Hanging Hook	2.9 (1.3)

^ NOT LISTED

New Unleaded Nozzles with BSP Inlet

MODEL NO.	DESCRIPTION	SHIPPING WEIGHT LBS (KG)
337016N^	with Single Notch Hold Open Clip	2.9 (1.3)

^ NOT LISTED

New Light Duty Diesel Nozzles with NPT Inlet

MODEL NO.	DESCRIPTION	SHIPPING WEIGHT LBS (KG)
337007	without Hold Open Clip	3.0 (1.4)
503407	without Hold Open Clip and Hanging Hook	2.9 (1.3)
337003N^	with Single Notch Hold Open Clip	3.0 (1.4)
337003NR^	with Single Notch Hold Open Clip - in Retail Packaging	3.0 (1.4)
503403N^	with Single Notch Hold Open Clip, without Hanging Hook	2.9 (1.3)
1700203N^	with Single Notch Hold Open Clip, without Hanging Hook	2.9 (1.3)

^ NOT LISTED

New Light Duty Diesel Nozzles with BSP Inlet

MODEL NO.	DESCRIPTION	SHIPPING WEIGHT LBS (KG)
337015N^	with Single Notch Hold Open Clip	3.0 (1.4)

^ NOT LISTED



⚠ WARNING: Cancer and Reproductive Harm - www.P65Warnings.ca.gov

XFS® Nozzles

Automatic shut-off nozzle for farm, 12V skid tanks and consumer pump applications.

Dimensions

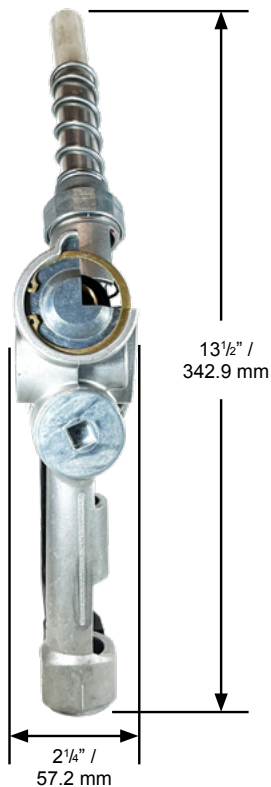
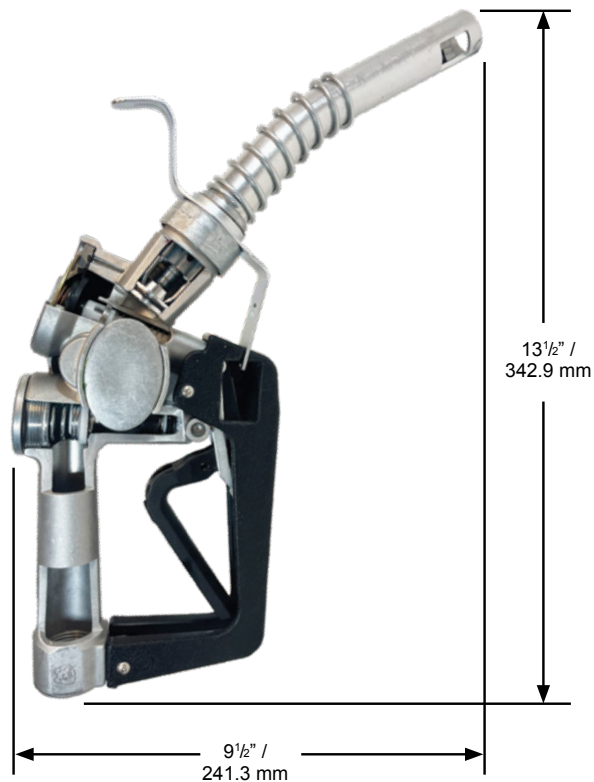

Construction

Body	One piece die cast aluminum with high-impact polymer handguard
Seals	Fluorocarbon
Packing	Double o-ring seal protected by fiber-reinforced Teflon®
Lever	One piece polymer
Inlet	3/4" (19 mm) NPT or 3/4" (19 mm) BSP

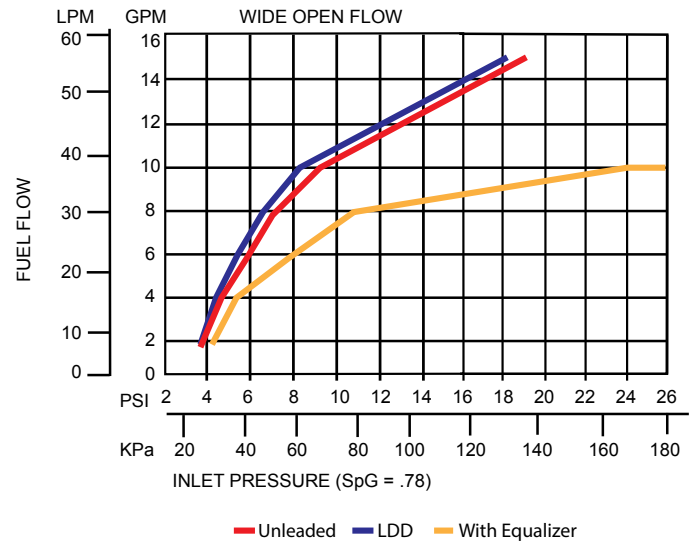

Automatic shut-off nozzle for farm, 12V skid tanks and consumer pump applications.

Nozzle Options

Nozzle Guard Options



Waffle Guard Options



1807 Waffle Guard



1808 Waffle Guard

Handguard Options



Standard Polymer Handguard

Gilbarco Polymer Handguard
(with or without Magnet)

Tokheim Polymer Handguard
(with or without Magnet)

Wayne Polymer Handguard
(with or without Magnet)

Lever Options



Lever without Hold Open Clip



Lever with Hold Open Clip

Latch Plate Options

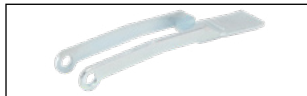

1 - Position Latch Plate

XFS® Nozzles

Automatic shut-off nozzle for farm, 12V skid tanks and consumer pump applications.

System Options

Safe-T-Breaks®

MODEL NO.	DESCRIPTION
002273	3/4" F x 3/4" F NPT Non-Reconnectable Safe-T-Break®
002774	3/4" F x 3/4" F BSPP Non-Reconnectable Safe-T-Break®
003360	3/4" F x 3/4" F NPT Reconnectable Safe-T-Break®
003385	3/4" F x 3/4" F BSPP Reconnectable Safe-T-Break®
005230	3/4" F x 3/4" F NPT Low Pull Reconnectable Safe-T-Break®
006130	3/4" F x 3/4" F NPT Non-Reconnectable PCC Safe-T-Break®
008330	3/4" F x 3/4" F NPT Reconnectable MAGBREAK®
009910	3/4" F x 3/4" F BSPP Reconnectable MAGBREAK®
010328	3/4" F x 3/4" F NPT Reconnectable High Pull MAGBREAK®
010330	3/4" F x 3/4" F BSPP Reconnectable High Pull MAGBREAK®
002774A	3/4" F x 3/4" F BSPP Non-Reconnectable Safe-T-Break® - Atex
003385A	3/4" F x 3/4" F BSPP Reconnectable Safe-T-Break® - Atex

Swivel/Safe-T-Break® Combos

MODEL NO.	DESCRIPTION
006310	3/4" M NPT Multi-Plane Swivel connected to 3/4" F NPT Reconnectable Safe-T-Break®
007085	3/4" M BSPP Multi-Plane Swivel connected to 3/4" F BSPP Reconnectable Safe-T-Break®
007085A	3/4" M BSPP Multi-Plane Swivel connected to 3/4" F BSPP Reconnectable Safe-T-Break® - Atex

Spouts

MODEL NO.	DESCRIPTION
001471	Light Duty Diesel Spout
001473	Unleaded Spout
010353	Light Duty Diesel Long Spout
010434	Unleaded Long Spout

Pressure/Vacuum Vents

MODEL NO.	DESCRIPTION
004620	2" Slip-On Pressure Vacuum Vent
004885	2" Thread-On Pressure Vacuum Vent - NPT
005885	2" Thread-On Pressure Vacuum Vent with Internal Screen - NPT

Accessories, Testing and Maintenance

MODEL NO.	DESCRIPTION
000397	Unleaded Spout Gauge
003593	Hold Open Clip Kit
004490	Conventional Flo-Equalizer® - 10 gpm / 37.9 Lpm
007089	Nozzle Service Kit
007490	Internal Flo-Equalizer® - 10 gpm / 37.9 Lpm

Swivels

MODEL NO.	DESCRIPTION
000350	3/4" M x 3/4" F NPT Multi-Plane Swivel
000355	3/4" M x 3/4" F NPT Multi-Plane Swivel Anodized Black
002272	3/4" M x 3/4" F NPT 90° Pump Swivel
002771	3/4" M x 3/4" F BSPP 90° Pump Swivel
002950	3/4" M x 3/4" F NPT Multi-Plane Restricted Swivel
003590	3/4" M x 3/4" F BSPP Multi-Plane Swivel
003895	3/4" M x 3/4" F NPT Inline Swivel
002771A	3/4" M x 3/4" F BSPP 90° Pump Swivel - Atex
003590A	3/4" M x 3/4" F BSPP Multi-Plane Swivel - Atex

Guards

MODEL NO.	DESCRIPTION
001506	Protection Package
001806	Full Grip Reguard
001807	Waffle Splash Guard with Small Hole
001808	Waffle Splash Guard
001809	Reguard Protection Package
003440	Mate Easy-On Package
003795	Mate Guard
004145	Full Grip Guard
006628	POPD® S Clear Cover
006665	POPD® S Full Grip Guard
007205	POPD® S Full Grip Reguard
007361	Black Handle Cover
007999	POPD® H Clear Cover
008165	POPD® S Mate Guard
008166	POPD® H Mate Guard
008175	POPD® EZS Nozzle Guard
008176	POPD® EZH Nozzle Guard
008185	POPD® H Full Grip Guard
008192	POPD® H Full Grip Reguard
014524	International Mate Package
014530	International Mate Guard
015247	International POPD® H Mate Guard
015253	International POPD® H Mate Package

Guard Color Chart

COLOR	SUFFIX	COLOR	SUFFIX	COLOR CUSTOM	SUFFIX
Blue	-01	Gold	-08	Amoco Blue	-07 CUSTOM
Red	-02	Silver	-09	Apple Green	-18 CUSTOM
Green	-03	BP Green	-16	Purple	-19 CUSTOM
Black	-04	M Blue	-21	Pink	-20 CUSTOM
Yellow	-05	Orange	-39	BPS Green	-22 CUSTOM
White	-06				

Scuff Guards are to be ordered with the corresponding guard color option added to the model number. Example: If BLUE guards are desired, add guard color option -01 to the model number (159504-01). For custom colors, a minimum order of 4,000 guards will be required.

1GS Nozzles

Automatic shut-off nozzle with polymer handguard for farm, 12V skid tanks, large pumps with or without air eliminators and commercial applications.

- 1GS nozzle shuts off when the gas tank is full.
- Stainless steel reinforced spout bushing keeps unleaded and light duty diesel spout tip round, and acts as a captive fastener to prevent tip-end sensor damage.
- Nozzle is equipped with a unique Flo-Stop® device that shuts off the nozzle if it falls from the fill neck or raises above the horizontal.
- Unleaded and light duty diesel *StreamShaper*® reduces turbulence for straighter fuel flow and less splash back spillage.
- Comes standard with smooth full grip guard and hanging hook
- Not for use with gravity tanks
- Not legal for retail dispensing applications
- ADA-compliant EZ Lever reduces the force required to open the main poppet valve by 50%, resulting in a lever operating force ≤5 lbs.



MODEL NO.
045707

New Unleaded PHG Nozzles with NPT Inlet

MODEL NO.	DESCRIPTION	SHIPPING WEIGHT LBS (KG)
045708	without Hold Open Clip, with Polymer Handguard	3.3 (1.4)
045704N^	with Two Notch Open Clip and Polymer Handguard	3.3 (1.4)
045704NR^	with Two Notch Open Clip and Polymer Handguard - in Retail Packaging	3.3 (1.4)
0457209N^	with Two Notch Hold Open Clip, Polymer Handguard and 385 Reducer Bushing	3.4 (1.5)

^ NOT LISTED

New Light Duty Diesel PHG Nozzles with NPT Inlet

MODEL NO.	DESCRIPTION	SHIPPING WEIGHT LBS (KG)
045707	without Hold Open Clip, with Polymer Handguard	3.3 (1.4)
045703N^	with Two Notch Open Clip and Polymer Handguard	3.3 (1.4)
045703NR^	with Two Notch Open Clip and Polymer Handguard - in Retail Packaging	3.3 (1.4)
0457208N^	with Two Notch Hold Open Clip, Polymer Handguard and 385 Reducer Bushing	3.4 (1.5)

^ NOT LISTED

New Light Duty Diesel PHG Nozzles with BSP Inlet

MODEL NO.	DESCRIPTION	SHIPPING WEIGHT LBS (KG)
045715N^	with Two Notch Open Clip and Polymer Handguard	3.3 (1.4)

^ NOT LISTED

New Heavy Duty Diesel PHG Nozzles with NPT Inlet

MODEL NO.	DESCRIPTION	SHIPPING WEIGHT LBS (KG)
045712	without Hold Open Clip, with Polymer Handguard	3.3 (1.4)
1096212	without Hold Open Clip, with Polymer Handguard and Cold Weather Seals	3.3 (1.4)
045709N^	with Two Notch Hold Open Clip, Polymer Handguard and 385 Reducer Bushing, without Flo-Stop®	3.4 (1.5)
045710N^	with Two Notch Open Clip and Polymer Handguard	3.3 (1.4)
045710NR^	with Two Notch Open Clip and Polymer Handguard - in Retail Packaging	3.3 (1.4)
1096210N^	with Two Notch Hold Open Clip, Polymer Handguard and Cold Weather Seals	3.3 (1.4)

^ NOT LISTED

New Heavy Duty Diesel PHG Nozzles with BSP Inlet

MODEL NO.	DESCRIPTION	SHIPPING WEIGHT LBS (KG)
045738N^	with Two Notch Open Clip and Polymer Handguard	3.3 (1.4)

^ NOT LISTED



WARNING: Cancer and Reproductive Harm - www.P65Warnings.ca.gov

1GS Nozzles

Automatic shut-off nozzle with polymer handguard for farm, 12V skid tanks, large pumps with or without air eliminators and commercial applications.

Dimensions

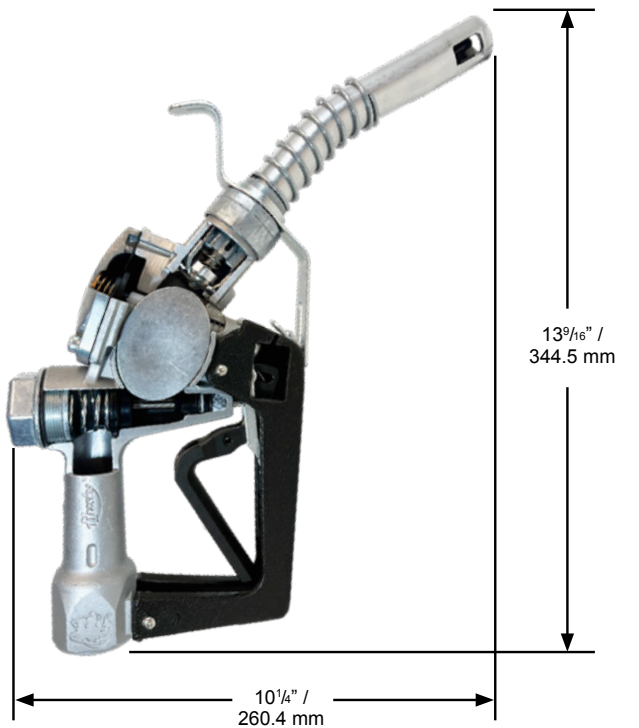

New Unleaded MHG Nozzles with NPT Inlet

MODEL NO.	DESCRIPTION	SHIPPING WEIGHT LBS (KG)
696204N [^]	with Two Notch Open Clip and Metal Handguard	3.4 (1.5)
6962209N [^]	with Two Notch Hold Open Clip, Metal Handguard and 385 Reducer Bushing	3.5 (1.6)

[^] NOT LISTED

New Light Duty Diesel MHG Nozzles with NPT Inlet

MODEL NO.	DESCRIPTION	SHIPPING WEIGHT LBS (KG)
696203N [^]	with Two Notch Open Clip and Metal Handguard	3.4 (1.5)
6962208N [^]	with Two Notch Hold Open Clip, Metal Handguard and 385 Reducer Bushing	3.5 (1.6)

[^] NOT LISTED

New Heavy Duty Diesel MHG Nozzles with NPT Inlet

MODEL NO.	DESCRIPTION	SHIPPING WEIGHT LBS (KG)
696210N [^]	with Two Notch Open Clip and Metal Handguard	3.4 (1.5)

[^] NOT LISTED

New Heavy Duty Diesel MHG Nozzles with BSP Inlet

MODEL NO.	DESCRIPTION	SHIPPING WEIGHT LBS (KG)
696238N [^]	with Two Notch Open Clip and Metal Handguard	3.4 (1.5)

[^] NOT LISTED

Construction

Body	One piece die cast aluminum with high-impact polymer or metal handguard
Seals	Fluorocarbon
Packing	Double o-ring seal protected by fiber-reinforced Teflon [®]
Lever	Two-piece polymer EZ Lever
Inlet	1" (25.4 mm) NPT or 1" (25.4 mm) BSP

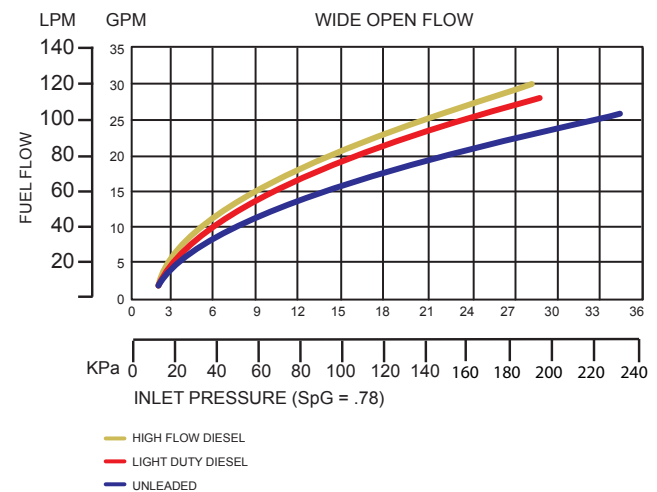

1GS Nozzles

Automatic shut-off nozzle with polymer handguard for farm, 12V skid tanks, large pumps with or without air eliminators and commercial applications.

Nozzle Options

Nozzle Guard Options



Full Grip Guard

POPD®S Full Grip Guard

POPD®H Full Grip Guard

Mate Guard

POPD®S Mate Guard

POPD®H Mate Guard

Waffle Guard Options

Reducer Bushing

Handguard Options



1808 Waffle Guard



000385



Standard Polymer Handguard

Standard Metal Handguard

Gilbarco Polymer Handguard
(with or without Magnet)

Tokheim Polymer Handguard
(with or without Magnet)

Wayne Polymer Handguard
(with or without Magnet)

Latch Plate Options

Lever Options

Hook Options

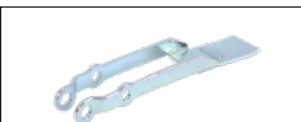

1 - Position Latch Plate

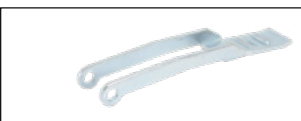

2 - Position Latch Plate



Lever without Hold Open Clip



Lever with Hold Open Clip



Nozzle with Hanging Hook



Nozzle without Hanging Hook

1GS Nozzles

Automatic shut-off nozzle with polymer handguard for farm, 12V skid tanks, large pumps with or without air eliminators and commercial applications.

System Options

Safe-T-Breaks®

MODEL NO.	DESCRIPTION
002276	1" F x 1" F NPT Reconnectable Safe-T-Break®
003076	1" F x 1" F BSPP Reconnectable Safe-T-Break®
003076A	1" F x 1" F BSPP Reconnectable Safe-T-Break® - Atex
005231	1" F x 1" F Low Pull NPT Reconnectable Safe-T-Break®
005812	1" F x 1" F NPT Non-Reconnectable Safe-T-Break®
006301	1" F x 1" F NPT Non-Reconnectable PCC Safe-T-Break®
006914	1" F x 1" F BSPP Non-Reconnectable Safe-T-Break®
008331	1" F x 1" F NPT CK Reconnectable MAGBREAK®
009911	1" F x 1" F BSPP Reconnectable G2 MAGBREAK®

Swivel/Safe-T-Break® Combos

MODEL NO.	DESCRIPTION
005969	1" M NPT Multi-Plane Swivel connected to 1" F NPT Reconnectable Safe-T-Break®
008015	1" M BSPP Multi-Plane Swivel connected to 1" F BSPP Reconnectable Safe-T-Break®
008015A	1" M BSPP Multi-Plane Swivel connected to 1" F BSPP Reconnectable Safe-T-Break® - Atex Spouts

Spouts

MODEL NO.	DESCRIPTION
001471	Light Duty Diesel Spout
001473	Unleaded Spout
005215	Heavy Duty Diesel Spout
010432	Unleaded Long Spout
012263	Light Duty Diesel Long Spout

Pressure/Vacuum Vents

MODEL NO.	DESCRIPTION
004620	2" Slip-On Pressure Vacuum Vent
004885	2" Thread-On Pressure Vacuum Vent - NPT
005885	2" Thread-On Pressure Vacuum Vent with Internal Screen - NPT

Accessories, Testing and Maintenance

MODEL NO.	DESCRIPTION
000385	1" M x 3/4" F Reducer Bushing
000397	Unleaded Spout Gauge
000548	Hanging Hook for Unleaded and Light Duty Diesel Nozzles
003593	Hold Open Clip Kit
007089	Nozzle Service Kit

Swivels

MODEL NO.	DESCRIPTION
000087	1" M x 1" F NPT Multi-Plane Swivel
000095	1" M x 1" F NPT 70° Multi-Plane Swivel
000352	1" M x 3/4" F NPT Multi-Plane Swivel
000356	1" M x 3/4" F NPT Multi-Plane Swivel Anodized Black
003306	1" M x 1" F BSPP Multi-Plane Swivel
003306A	1" M x 1" F BSPP Multi-Plane Swivel - Atex
003395	1" M x 1" F NPT Multi-Plane Restricted Swivel
004860	1" M x 1" F NPT Multi-Plane High Volume Swivel
006949	1" M x 1" F BSPP Multi-Plane High Volume Swivel

Guards

MODEL NO.	DESCRIPTION
000099	Protection Package
000226	Mate Nozzle Guard
000554	Full Grip Guard
001804	Full Grip Reguard
001808	Waffle Splash Guard
001811	Reguard Protection Package
005494	Lever Guard
006628	POPD® S Clear Cover
006655	POPD® S Full Grip Guard
007210	POPD® S Full Grip Reguard
007295	Mate Handle Guard
007999	POPD® H Clear Cover
008169	POPD® S Mate Nozzle Guard
008170	POPD® H Mate Nozzle Guard
008179	POPD® EZS Nozzle Guard
008180	POPD® EZH Nozzle Guard
008183	POPD® H Full Grip Guard
008190	POPD® H Full Grip Reguard

Guard Color Chart

COLOR	SUFFIX	COLOR	SUFFIX	COLOR <i>CUSTOM</i>	SUFFIX
Blue	-01	Gold	-08	Amoco Blue	-07 <i>CUSTOM</i>
Red	-02	Silver	-09	Apple Green	-18 <i>CUSTOM</i>
Green	-03	BP Green	-16	Purple	-19 <i>CUSTOM</i>
Black	-04	M Blue	-21	Pink	-20 <i>CUSTOM</i>
Yellow	-05	Orange	-39	BPS Green	-22 <i>CUSTOM</i>
White	-06				

Scuff Guards are to be ordered with the corresponding guard color option added to the model number. Example: If BLUE guards are desired, add guard color option -01 to the model number (159504-01). For custom colors, a minimum order of 4,000 guards will be required.

1GSS Nozzles

Pressure-activated, automatic shut-off nozzle with polymer handguard for farm, 12V skid tanks, large pumps with or without air eliminators and commercial applications.

- 1GSS nozzle shuts off when:
 - the pump shuts off
 - the gas tank is full
 - the lever is opened before the pump is turned on
 - the leak detector has not completed the test cycle
- Comes standard with smooth full grip guard and hanging hook
- Not for use with gravity tanks
- Not legal for retail dispensing applications
- ADA-compliant EZ Lever reduces the force required to open the main poppet valve by 50%, resulting in a lever operating force ≤5 lbs.
- Stainless steel reinforced spout bushing keeps unleaded and light duty diesel spout tip round, and acts as a captive fastener to prevent tip-end sensor damage.
- Nozzle is equipped with a unique Flo-Stop® device that shuts off the nozzle if it falls from the fill neck or raises above the horizontal.
- Unleaded and light duty diesel *StreamShaper*® reduces turbulence for straighter fuel flow and less splash back spillage.



MODEL NO.
1216503

New Unleaded PHG Nozzles with NPT Inlet

MODEL NO.	DESCRIPTION	SHIPPING WEIGHT LBS (KG)
1216504	with Two Notch Hold Open Clip and Polymer Handguard	3.3 (1.4)

New Light Duty Diesel PHG Nozzles with NPT Inlet

MODEL NO.	DESCRIPTION	SHIPPING WEIGHT LBS (KG)
1216503	with Two Notch Hold Open Clip and Polymer Handguard	3.3 (1.4)

New Heavy Duty Diesel PHG Nozzles with NPT Inlet

MODEL NO.	DESCRIPTION	SHIPPING WEIGHT LBS (KG)
1216510	with Two Notch Hold Open Clip and Polymer Handguard	3.3 (1.4)



WARNING: Cancer and Reproductive Harm - www.P65Warnings.ca.gov

1GSS Nozzles

Pressure-activated, automatic shut-off nozzle with polymer handguard for farm, 12V skid tanks, large pumps with or without air eliminators and commercial applications.

Dimensions

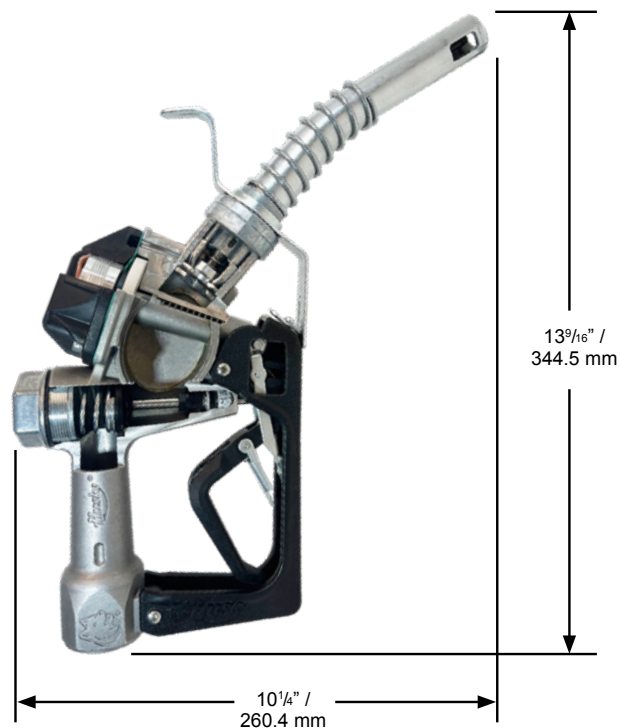

New Unleaded MHG Nozzles with NPT Inlet

MODEL NO.	DESCRIPTION	SHIPPING WEIGHT LBS (KG)
1216804	with Two Notch Hold Open Clip and Metal Handguard	3.5 (1.6)

New Light Duty Diesel MHG Nozzles with NPT Inlet

MODEL NO.	DESCRIPTION	SHIPPING WEIGHT LBS (KG)
1216803	with Two Notch Hold Open Clip and Metal Handguard	3.5 (1.6)

New Heavy Duty Diesel MHG Nozzles with NPT Inlet

MODEL NO.	DESCRIPTION	SHIPPING WEIGHT LBS (KG)
1216810	with Two Notch Hold Open Clip and Metal Handguard	3.3 (1.4)

Construction

Body	One piece die cast aluminum with high-impact polymer or metal handguard
Seals	Fluorocarbon
Packing	Double o-ring seal protected by fiber-reinforced Teflon®
Lever	Two-piece polymer EZ Lever
Inlet	1" (25.4 mm) NPT or 1" (25.4 mm) BSP

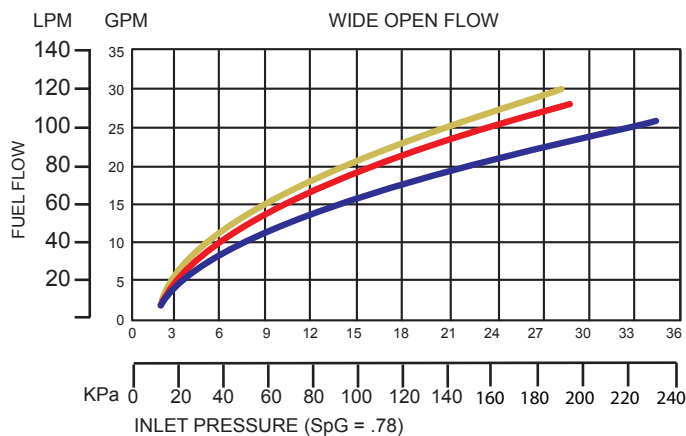

1GSS Nozzles

Pressure-activated, automatic shut-off nozzle with polymer handguard for farm, 12V skid tanks, large pumps with or without air eliminators and commercial applications.

Nozzle Options

Nozzle Guard Options



Full Grip Guard

POPD®S Full Grip Guard

POPD®H Full Grip Guard

Mate Guard

POPD®S Mate Guard

POPD®H Mate Guard

Waffle Guard Options



1808 Waffle Guard

Handguard Options



Standard Polymer Handguard

Standard Metal Handguard

Gilbarco Polymer Handguard

(with or without Magnet)

Tokheim Polymer Handguard

(with or without Magnet)

Wayne Polymer Handguard

(with or without Magnet)

Latch Plate Options

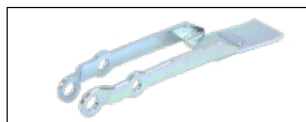

1 - Position Latch Plate

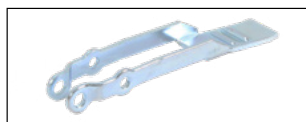

2 - Position Latch Plate

Lever Options



Lever without Hold Open Clip

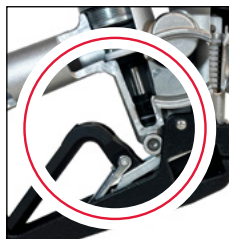

Lever with Hold Open Clip

Hook Options



Nozzle with Hanging Hook



Nozzle without Hanging Hook

1GSS Nozzles

Pressure-activated, automatic shut-off nozzle with polymer handguard for farm, 12V skid tanks, large pumps with or without air eliminators and commercial applications.

System Options

Safe-T-Breaks®

MODEL NO.	DESCRIPTION
002276	1" F x 1" F NPT Reconnectable Safe-T-Break®
003076	1" F x 1" F BSPP Reconnectable Safe-T-Break®
003076A	1" F x 1" F BSPP Reconnectable Safe-T-Break® - Atex
005231	1" F x 1" F Low Pull NPT Reconnectable Safe-T-Break®
005812	1" F x 1" F NPT Non-Reconnectable Safe-T-Break®
006301	1" F x 1" F NPT Non-Reconnectable PCC Safe-T-Break®
006914	1" F x 1" F BSPP Non-Reconnectable Safe-T-Break®
008331	1" F x 1" F NPT CK Reconnectable MAGBREAK®
009911	1" F x 1" F BSPP Reconnectable G2 MAGBREAK®

Swivel/Safe-T-Break® Combos

MODEL NO.	DESCRIPTION
005969	1" M NPT Multi-Plane Swivel connected to 1" F NPT Reconnectable Safe-T-Break®
008015	1" M BSPP Multi-Plane Swivel connected to 1" F BSPP Reconnectable Safe-T-Break®
008015A	1" M BSPP Multi-Plane Swivel connected to 1" F BSPP Reconnectable Safe-T-Break® - Atex Spouts

Spouts

MODEL NO.	DESCRIPTION
001471	Light Duty Diesel Spout
001473	Unleaded Spout
005215	Heavy Duty Diesel Spout
010432	Unleaded Long Spout
012263	Light Duty Diesel Long Spout

Pressure/Vacuum Vents

MODEL NO.	DESCRIPTION
004620	2" Slip-On Pressure Vacuum Vent
004885	2" Thread-On Pressure Vacuum Vent - NPT
005885	2" Thread-On Pressure Vacuum Vent with Internal Screen - NPT

Accessories, Testing and Maintenance

MODEL NO.	DESCRIPTION
000385	1" M x 3/4" F Reducer Bushing
000397	Unleaded Spout Gauge
000548	Hanging Hook for Unleaded and Light Duty Diesel Nozzles
003593	Hold Open Clip Kit
007089	Nozzle Service Kit

















Swivels

MODEL NO.	DESCRIPTION
000087	1" M x 1" F NPT Multi-Plane Swivel
000095	1" M x 1" F NPT 70° Multi-Plane Swivel
000352	1" M x 3/4" F NPT Multi-Plane Swivel
000356	1" M x 3/4" F NPT Multi-Plane Swivel Anodized Black
003306	1" M x 1" F BSPP Multi-Plane Swivel
003306A	1" M x 1" F BSPP Multi-Plane Swivel - Atex
003395	1" M x 1" F NPT Multi-Plane Restricted Swivel
004860	1" M x 1" F NPT Multi-Plane High Volume Swivel
006949	1" M x 1" F BSPP Multi-Plane High Volume Swivel

Guards

MODEL NO.	DESCRIPTION
001807	Waffle Splash Guard with Smaller Hole
001808	Waffle Splash Guard
005494	Lever Guard
007295	Mate Handle Guard
012164	Full Grip Guard

Guard Color Chart

COLOR	SUFFIX	COLOR	SUFFIX	COLOR <i>CUSTOM</i>	SUFFIX
	-01		-08		-07 <i>CUSTOM</i>
	-02		-09		-18 <i>CUSTOM</i>
	-03		-16		-19 <i>CUSTOM</i>
	-04		-21		-20 <i>CUSTOM</i>
	-05		-39		-22 <i>CUSTOM</i>
	-06				

Scuff Guards are to be ordered with the corresponding guard color option added to the model number. Example: If BLUE guards are desired, add guard color option -01 to the model number (159504-01). For custom colors, a minimum order of 4,000 guards will be required.



Diesel Exhaust Fluid Nozzles



SST DEF Nozzles

Automatic shut-off Diesel Exhaust Fluid (DEF) nozzle for full-service and self-service stations.

- SST DEF nozzle shuts off when tank is full.
- Comes standard with mate nozzle guard and handle cover
- Modular design for easy cleaning
- Stainless Steel construction
- Constructed from materials 100% compatible with Diesel Exhaust Fluid (DEF)
- Available with magnetic Accufuel® safety feature
- Equipped with a unique Flo-Stop® device that shuts off the nozzle if it falls from the fill tank or raises above the horizontal.

DEF Nozzles with 1" BSPP

MODEL NO.	DESCRIPTION	SHIPPING WEIGHT LBS (KG)
731004N [^]	with Two Notch Hold Open Clip;	4.6 (2.1)
731091N [^]	with Two Notch Hold Open Clip, Spout Ring and magnetic Accufuel® Spout	4.6 (2.1)

[^] NOT LISTED

DEF Nozzles with M34

MODEL NO.	DESCRIPTION	SHIPPING WEIGHT LBS (KG)
1043691N [^]	with Two Notch Hold Open Clip, Spout Ring, magnetic Accufuel® Spout, and Waffle Guard	4.6 (2.1)

[^] NOT LISTED



MODEL NO.
731004N



WARNING: Cancer and Reproductive Harm - www.P65Warnings.ca.gov

SST DEF Nozzles

Automatic shut-off Diesel Exhaust Fluid (DEF) nozzle for full-service and self-service stations.

Dimensions

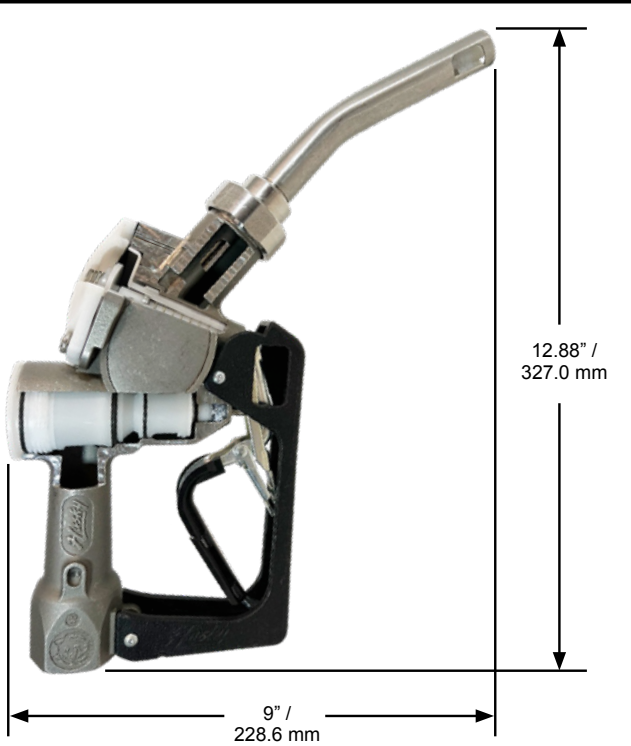

Construction

Body	Investment Cast Stainless Steel
Seals	Fluorocarbon
Packing	Double o-ring seal protected by fiber reinforced Teflon®
Lever	One piece contoured steel with hard plastic cover
Inlet	1" / 25.4 mm BSPP or M34 x 1.5

SST DEF NOZZLE AVERAGE BACK PRESSURE PERFORMANCE VERIFICATION

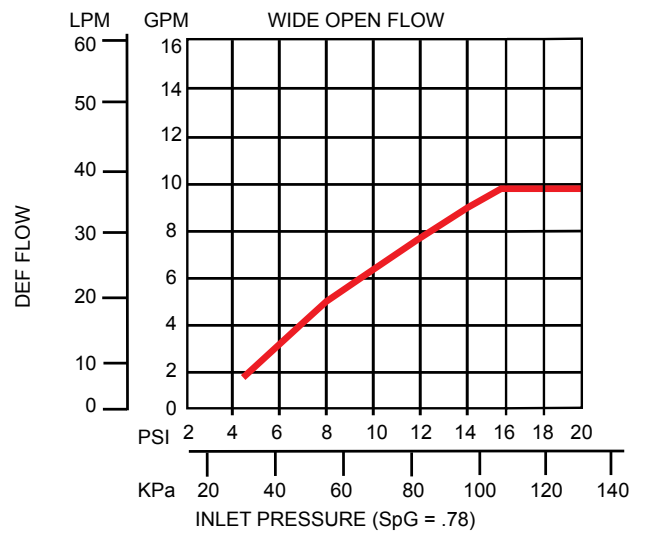

SST DEF Nozzles

Automatic shut-off Diesel Exhaust Fluid (DEF) nozzle for full-service and self-service stations.

Nozzle Options

Nozzle Guard Options



Full Grip Guard

Mate Guard

Handguard Options



Standard Polymer Handguard

Gilbarco Polymer Handguard
(with or without Magnet)

Tokheim Polymer Handguard
(with or without Magnet)

Wayne Polymer Handguard
(with or without Magnet)

Lever Options

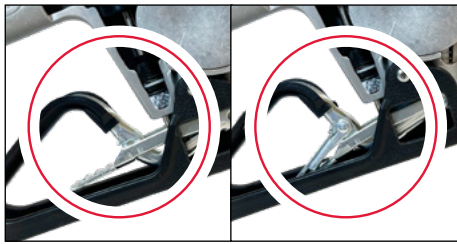

Lever without Hold Open Clip

Lever with Hold Open Clip

Waffle Guard Options



1808 Waffle Guard

Latch Plate Options

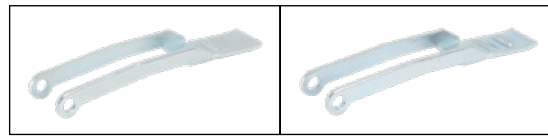

1 - Position Latch Plate

2 - Position Latch Plate

SST DEF Nozzles

Automatic shut-off Diesel Exhaust Fluid (DEF) nozzle for full-service and self-service stations.

System Options

Safe-T-Breaks®

MODEL NO.	DESCRIPTION
007219	1" M x 1" M BSPP Non-Reconnectable Stainless Steel Safe-T-Break®
008216	1" M x 1" M BSPP Reconnectable Stainless Steel Safe-T-Break®

Swivels

MODEL NO.	DESCRIPTION
007269	1" M x 1" M BSPP Inline Swivel
007275	1" M BSPP x M34 M Inline Swivel
007282	3/4" M BSPP x 3/4" Hose Barb Roller Bearing Inline Swivel
007467	1" F x 1" M BSPP Inline Swivel
008510	1" M BSPP 1" F NPT Inline Swivel
010936	3/4" M BSPP X 3/4" Hose Barb Inline Swivel

Spouts

MODEL NO.	DESCRIPTION
007360	with Spout Ring and Flo-Stop®
007362	with Flo-Stop®
007364	with Spout Ring and Magnetic Accufuel® Safety Feature

Guards

MODEL NO.	DESCRIPTION
000226	Mate Nozzle Guard
000554	Full Grip Guard
001808	Waffle Splash Guard
007376	Handle Cover (Black)
008429	DEF Handguard Repair Kit

Adaptors

MODEL NO.	DESCRIPTION
007285	1" M x 1" M BSPP Straight Adaptor
007356	1" M BSPP x M M34 Straight Adaptor
008413	1" M BSPP x 3/4" Hose Barb Adaptor with Seal Kit

















Accessories, Testing and Maintenance

MODEL NO.	DESCRIPTION
007150	Poppet Valve / Venturi Cartridge Assembly
007160	Plunger Cartridge Assembly
007163	Loss Motion Diaphragm Cartridge Assembly
007523	1" BSPP Seal Kit Assembly

Swivel/Safe-T-Break® Combos

MODEL NO.	DESCRIPTION
013185	M34 M NPT Multi-Plane Swivel connected to 1" BSP M Reconnectable Safe-T-Break®
014438	1" BSP M Multi-Plane Swivel connected to 1" BSP M Reconnectable Safe-T-Break®

Guard Color Chart

COLOR	SUFFIX	COLOR	SUFFIX	COLOR <i>CUSTOM</i>	SUFFIX
 Blue	-01	 Gold	-08	 Amoco Blue	-07 <i>CUSTOM</i>
 Red	-02	 Silver	-09	 Apple Green	-18 <i>CUSTOM</i>
 Green	-03	 BP Green	-16	 Purple	-19 <i>CUSTOM</i>
 Black	-04	 M Blue	-21	 Pink	-20 <i>CUSTOM</i>
 Yellow	-05	 Orange	-39	 BPS Green	-22 <i>CUSTOM</i>
 White	-06				

Scuff Guards are to be ordered with the corresponding guard color option added to the model number. Example: If BLUE guards are desired, add guard color option -01 to the model number (159504-01). For custom colors, a minimum order of 4,000 guards will be required.

POLY DEF **Nozzles**

Polymer shut-off Diesel Exhaust Fluid (DEF) nozzle for full-service stations.

- POLY DEF nozzle shuts off when tank is full.
- Lighter than stainless steel nozzles
- *StreamShaper*[®] reduces turbulence for straighter fuel flow and less splash back spillage.
- Less expensive than comparable nozzles
- Stainless steel spout for durability
- Replaceable stainless steel spout
- Available with magnetic Accufuel[®] safety feature
- ADA-compliant EZ Lever reduces the force required to open the main poppet valve by 50%, resulting in a lever operating force ≤5 lbs.
- Flow characteristics of nozzle reduces crystallization of DEF.
- Complies with ISO Standard 22241-2:2006

New Polymer DEF Nozzle with 1" BSPP

MODEL NO.	DESCRIPTION	SHIPPING WEIGHT LBS (KG)
873504N [^]	with Two Notch Hold Open Clip	1.53 (0.7)
873508	without Two Notch Hold Open Clip, Spout Ring and magnetic Accufuel [®] Spout	1.53 (0.7)
873504NR [^]	with Two Notch Hold Open Clip and Retail Packaging	1.53 (0.7)
873588N [^]	with Two Notch Hold Open Clip and Spout Ring	1.53 (0.7)
873591N [^]	with Two Notch Hold Open Clip, Spout Ring and magnetic Accufuel [®] Spout	1.53 (0.7)
1202991N [^]	with Two Notch Hold Open Clip, Spout Ring, magnetic Accufuel [®] Spout, and Gilbarco Magnetic Hand Guard	1.53 (0.7)



MODEL NO.
873504N



 WARNING: Cancer and Reproductive Harm - www.P65Warnings.ca.gov

POLY DEF Nozzles

Polymer shut-off Diesel Exhaust Fluid (DEF) nozzle for full-service stations.

Dimensions

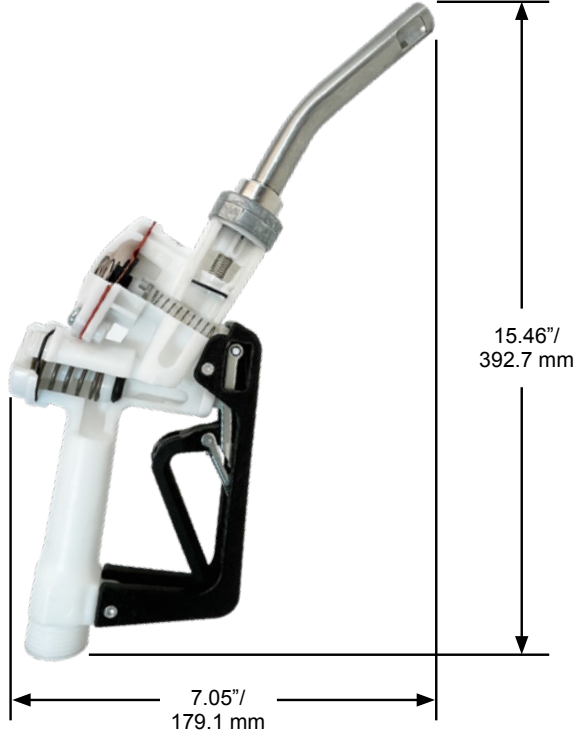

Construction

Body	Investment Cast Stainless Steel
Seals	Fluorocarbon
Spout	19 mm diameter
Packing	Double o-ring seal protected by fiber reinforced Teflon®
Lever	Two piece polymer EZ Lever
Inlet	1" (25.4 mm) BSPP Male Threads or M34 1.5 Male Threads with Face Seal

POLY DEF NOZZLE AVERAGE BACK PRESSURE PERFORMANCE VERIFICATION

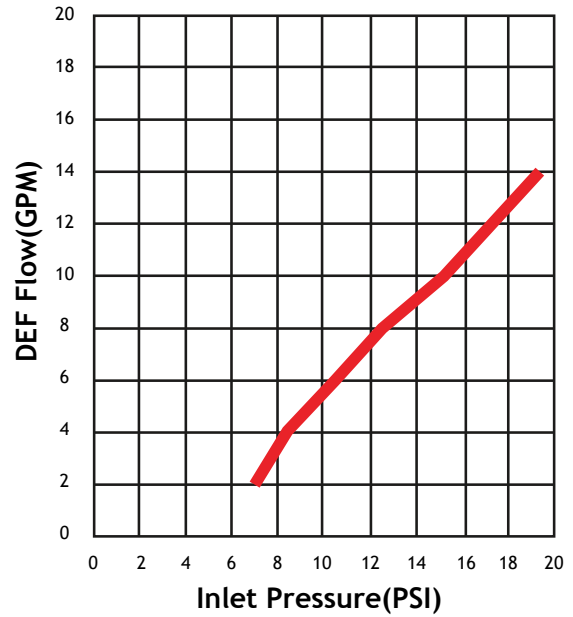

POLY DEF **Nozzles**

Polymer shut-off Diesel Exhaust Fluid (DEF) nozzle for full-service stations.

Nozzle Options

Nozzle Guard Options



Full Grip Guard

Mate Guard

Handguard Options



Standard Polymer Handguard

Gilbarco Polymer Handguard
(with or without Magnet)

Tokheim Polymer Handguard
(with or without Magnet)

Wayne Polymer Handguard
(with or without Magnet)

Lever Options

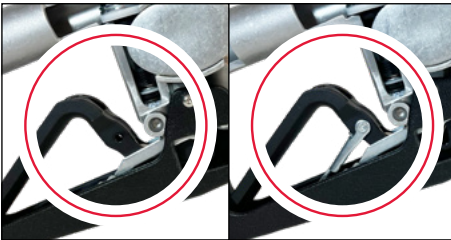

Lever without Hold Open Clip

Lever with Hold Open Clip

Waffle Guard Options



1808 Waffle Guard

Latch Plate Options

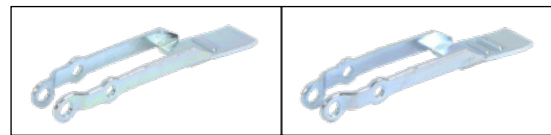

1 - Position Latch Plate

2 - Position Latch Plate

POLY DEF Nozzles

Polymer shut-off Diesel Exhaust Fluid (DEF) nozzle for full-service stations.

System Options

Safe-T-Breaks®

MODEL NO.	DESCRIPTION
007219	1" M x 1" M BSPP Non-Reconnectable Stainless Steel Safe-T-Break®

Swivels

MODEL NO.	DESCRIPTION
007269	1" M x 1" M BSPP Inline Swivel
007275	1" M BSPP x M34 M Inline Swivel
007282	3/4" M BSPP x 3/4" Hose Barb Roller Bearing Inline Swivel
007467	1" F x 1" M BSPP Inline Swivel
008510	1" M BSPP 1" F NPT Inline Swivel
010936	3/4" M BSPP X 3/4" Hose Barb Inline Swivel

Spouts

MODEL NO.	DESCRIPTION
013591	with StreamShaper®
013592	with Spout Ring and StreamShaper®
013593	with Spout Ring and Magnetic Accufuel® Safety Feature

Guards

MODEL NO.	DESCRIPTION
000226	Mate Nozzle Guard
000554	Full Grip Guard
001808	Waffle Splash Guard
007376	Handle Cover (Black)
008429	DEF Handguard Repair Kit

Adaptors

MODEL NO.	DESCRIPTION
007285	1" M x 1" M BSPP Straight Adaptor
007356	1" M BSPP x M M34 Straight Adaptor
008413	1" M BSPP x 3/4" Hose Barb Adaptor with Seal Kit

Accessories, Testing and Maintenance

MODEL NO.	DESCRIPTION
007523	1" BSPP Seal Kit Assembly

Swivel/Safe-T-Break® Combos

MODEL NO.	DESCRIPTION
013185	M34 M NPT Multi-Plane Swivel connected to 1" BSP M Reconnectable Safe-T-Break®
014438	1" BSP M Multi-Plane Swivel connected to 1" BSP M Reconnectable Safe-T-Break®

Guard Color Chart

COLOR	SUFFIX	COLOR	SUFFIX	COLOR <i>CUSTOM</i>	SUFFIX
Blue	-01	Gold	-08	Amoco Blue	-07 <i>CUSTOM</i>
Red	-02	Silver	-09	Apple Green	-18 <i>CUSTOM</i>
Green	-03	BP Green	-16	Purple	-19 <i>CUSTOM</i>
Black	-04	M Blue	-21	Pink	-20 <i>CUSTOM</i>
Yellow	-05	Orange	-39	BPS Green	-22 <i>CUSTOM</i>
White	-06				

Scuff Guards are to be ordered with the corresponding guard color option added to the model number. Example: If BLUE guards are desired, add guard color option -01 to the model number (159504-01). For custom colors, a minimum order of 4,000 guards will be required.

X DEF Nozzles

Automatic shut-off Diesel Exhaust Fluid (DEF) nozzle for full-service and self-service stations.

- X DEF nozzle shuts off when tank is full.
- Lighter than stainless steel nozzles
- *StreamShaper*[®] reduces turbulence for straighter fuel flow and less splash back spillage.
- Less expensive than comparable nozzles
- Tilt poppet design provides precise “to-the-penny” dispensing.
- Stainless steel spout for durability
- Flow characteristics of nozzle reduces crystallization of DEF.
- Complies with ISO Standard 22241-2:2006



MODEL NO.
11676155N

New X DEF Nozzle with 3/4" NPT

MODEL NO.	DESCRIPTION	SHIPPING WEIGHT LBS (KG)
11676155N [^]	with Two Notch Hold Open Clip	3.0 (1.3)
11676188N [^]	with Two Notch Hold Open Clip, Spout Ring and Magnetic Accufuel [®] Spout	3.0 (1.3)
11676189N [^]	with Two Notch Hold Open Clip and Long Spout	3.0 (1.3)
12150155N [^]	with Two Notch Hold Open Clip and Gilbarco Magnetic Handguard	3.0 (1.3)
12970155N [^]	with Two Notch Hold Open Clip and Wayne Magnetic Handguard	3.0 (1.3)

[^] NOT LISTED

New X DEF Nozzle with 3/4" BSP

MODEL NO.	DESCRIPTION	SHIPPING WEIGHT LBS (KG)
1167691N [^]	with Two Notch Hold Open Clip, Spout Ring and Magnetic Accufuel [®] Spout	3.0 (1.3)
11676154N [^]	with Two Notch Hold Open Clip	3.0 (1.3)
11676180N [^]	with Two Notch Hold Open Clip without Waffle Guard	3.0 (1.3)
11676190N [^]	with Two Notch Hold Open Clip and Long Spout	3.0 (1.3)
11676290N [^]	with Two Notch Hold Open Clip, Spout Ring and Magnetic Accufuel [®] Long Spout	3.0 (1.3)
12150154N [^]	with Two Notch Hold Open Clip and Gilbarco Magnetic Handguard	3.0 (1.3)
1215091N [^]	with Two Notch Hold Open Clip, Spout Ring, Magnetic Accufuel [®] Spout and Gilbarco Magnetic Handguard	3.0 (1.3)
12964154N [^]	with Two Notch Hold Open Clip, and Wayne Magnetic Handguard without Spout Groove	3.0 (1.3)
12970154N [^]	with Two Notch Hold Open Clip and Wayne Magnetic Handguard	3.0 (1.3)
13410204N [^]	with Two Notch Hold Open Clip, without Spout Groove	3.0 (1.3)
11676302N [^]	with Two Notch Hold Open Clip, without Spout Groove and Flo-Equalizer [®] (3 gpm)	3.0 (1.3)

[^] NOT LISTED



WARNING: Cancer and Reproductive Harm - www.P65Warnings.ca.gov

X DEF Nozzles

Automatic shut-off Diesel Exhaust Fluid (DEF) nozzle for full-service and self-service stations.

Dimensions

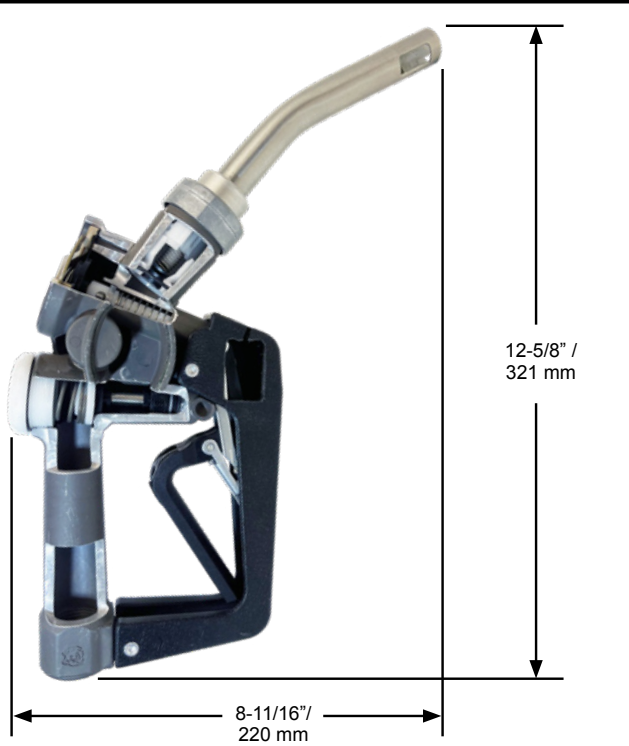

Construction

Body	Anodized Aluminum
Seals	Fluorocarbon
Spout	19 mm diameter
Packing	Double o-ring seal protected by fiber-reinforced Teflon®
Lever	One-piece polymer
Inlet	3/4" / 19 mm NPT or 3/4" / 19 mm BSPP

X DEF NOZZLE AVERAGE BACK PRESSURE PERFORMANCE VERIFICATION

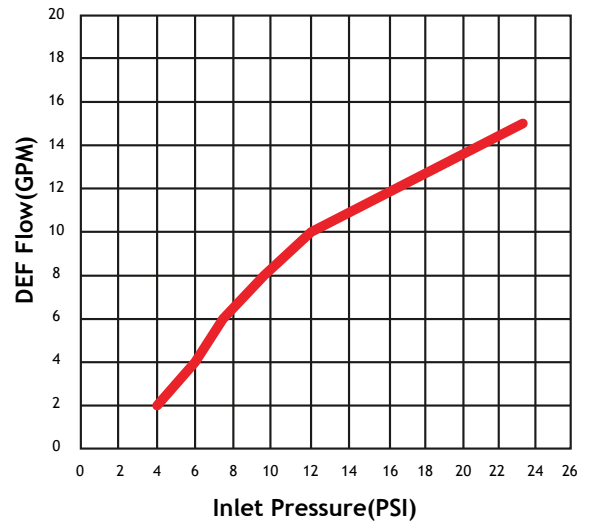

X DEF Nozzles

Automatic shut-off Diesel Exhaust Fluid (DEF) nozzle for full-service and self-service stations.

Nozzle Options

Nozzle Guard Options



Full Grip Guard

Mate Guard

Handguard Options



Standard Polymer Handguard

Gilbarco Polymer Handguard
(with or without Magnet)

Tokheim Polymer Handguard
(with or without Magnet)

Wayne Polymer Handguard
(with or without Magnet)

Lever Options

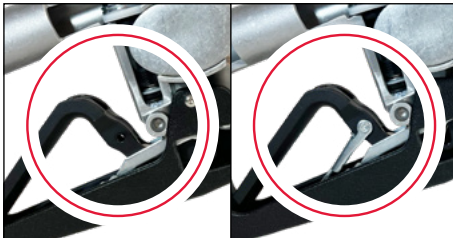

Lever without Hold Open Clip

Lever with Hold Open Clip

Waffle Guard Options



1808 Waffle Guard

Latch Plate Options

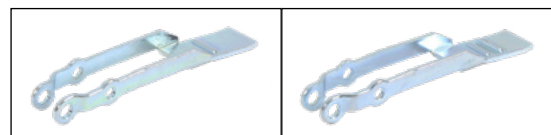

1 - Position Latch Plate

2 - Position Latch Plate

X DEF Nozzles

Automatic shut-off Diesel Exhaust Fluid (DEF) nozzle for full-service and self-service stations.

System Options

Safe-T-Breaks®

MODEL NO.	DESCRIPTION
012070	3/4" F x 3/4" F NPT Reconnectable Safe-T-Break®
012659	3/4" F x 3/4" F BSPP Reconnectable Safe-T-Break®

Swivels

MODEL NO.	DESCRIPTION
007282	3/4" M BSPP x 3/4" Hose Barb Roller Bearing Inline Swivel
010936	3/4" M BSPP x 3/4" Hose Barb Inline Swivel
012604	3/4" M x 3/4" F NPT Roller Bearing Inline Swivel
012656	3/4" M x 3/4" F BSPP Roller Bearing Inline Swivel

Spouts

MODEL NO.	DESCRIPTION
007360	with Spout Ring and Flo-Stop®
007362	with Flo-Stop®
007364	with Spout Ring and Magnetic Accufuel® Safety Feature

Guards

MODEL NO.	DESCRIPTION
001808	Waffle Splash Guard
003795	Mate Nozzle Guard
004145	Full Nozzle Guard
007361	Handle Cover (Black)
014114	International Mate Nozzle Guard

















Accessories, Testing and Maintenance

MODEL NO.	DESCRIPTION
007522	3/4" BSPP Seal Kit Assembly
013285	with StreamShaper®
013286	with Spout Ring and Magnetic Accufuel® Safety Feature
015319	with Long Spout and StreamShaper®

Swivel/Safe-T-Break® Combos

MODEL NO.	DESCRIPTION
012828	3/4" BSP M Multi-Plane Swivel connected to 3/4" BSP F Reconnectable Safe-T-Break®
012831	3/4" NPT M Multi-Plane Swivel connected to 3/4" NPT F Reconnectable Safe-T-Break®
012887	3/4" BSP M Multi-Plane Swivel connected to 1" BSP F Reconnectable Safe-T-Break®
012890	3/4" BSP M Multi-Plane Swivel connected to 1" BSP M Reconnectable Safe-T-Break®

Guard Color Chart

COLOR	SUFFIX	COLOR	SUFFIX	COLOR <i>CUSTOM</i>	SUFFIX
 Blue	-01	 Gold	-08	 Amoco Blue	-07 <i>CUSTOM</i>
 Red	-02	 Silver	-09	 Apple Green	-18 <i>CUSTOM</i>
 Green	-03	 BP Green	-16	 Purple	-19 <i>CUSTOM</i>
 Black	-04	 M Blue	-21	 Pink	-20 <i>CUSTOM</i>
 Yellow	-05	 Orange	-39	 BPS Green	-22 <i>CUSTOM</i>
 White	-06				

Scuff Guards are to be ordered with the corresponding guard color option added to the model number. Example: If BLUE guards are desired, add guard color option -01 to the model number (159504-01). For custom colors, a minimum order of 4,000 guards will be required.



Conventional Ethanol Fueling Nozzles

XS[®] E25 Nozzles

CONVENTIONAL ETHANOL FUELING

Pressure-activated, automatic shut-off nozzle for full-service and self-service stations.

- XS E25 nozzle shuts off when:
 - the pump shuts off
 - the gas tank is full
 - the lever is opened before the pump is turned on
 - the leak detector has not completed the test cycle
- Stainless steel reinforced spout bushing keeps spout tip round, and acts as a captive fastener to prevent tip-end sensor damage.
- Nozzle is equipped with a unique Flo-Stop[®] device that shuts off the nozzle if it falls from the fill neck or raises above the horizontal.
- *StreamShaper*[®] reduces turbulence for straighter fuel flow and less splash back spillage.
- New poppet seal design in conjunction with new tilt poppet design improves flow control (“to-the-penny” dispensing) and provides enhanced endurance over time.
- Optional cold weather seals are rated to -40° F/C.
- Optional Gilbarco, Tokheim, and Wayne handguards can be fitted with a magnet to trigger the dispenser’s proximity switch, or can be provided without the magnet for dispensers equipped with a standard “flapper” switch.
- All seals are UL approved fluorocarbon compounds to prevent degradation from Ethanol blends.
- Compatible with unleaded and all Ethanol blends through E-25
- Comes standard with smooth full grip guard
- ADA-compliant EZ Lever reduces the force required to open the main poppet valve by 50%, resulting in a lever operating force ≤5 lbs.



MODEL NO.
1108459

New Unleaded Nozzles with NPT Inlet

MODEL NO.	DESCRIPTION	SHIPPING WEIGHT LBS (KG)
1108459	with Two Notch Hold Open Clip, 1808 Waffle Splash Guard and Cold Weather Seals	3.1 (1.4)
1108689	with Single Notch Hold Open Clip, POPD's and 1808 Waffle Splash Guard	3.2 (1.5)
11086179	with Single Notch Hold Open Clip and 1808 Waffle Splash Guard	3.1 (1.4)
1108659	with Two notch hold open clip and 1808 Waffle Splash Guard	3.1 (1.4)
E1108604	with Two Notch Hold Open Clip, Mate Guard and Polymer Handle Cover	3.0 (1.4)
E1108659	with Two Notch Hold Open Clip, Mate Guard, Polymer Handle Cover and 1808 Waffle Splash Guard	3.1 (1.4)



WARNING: Cancer and Reproductive Harm - www.P65Warnings.ca.gov

XS[®] E25 Nozzles

Pressure-activated, automatic shut-off nozzle for full-service and self-service stations.

Dimensions

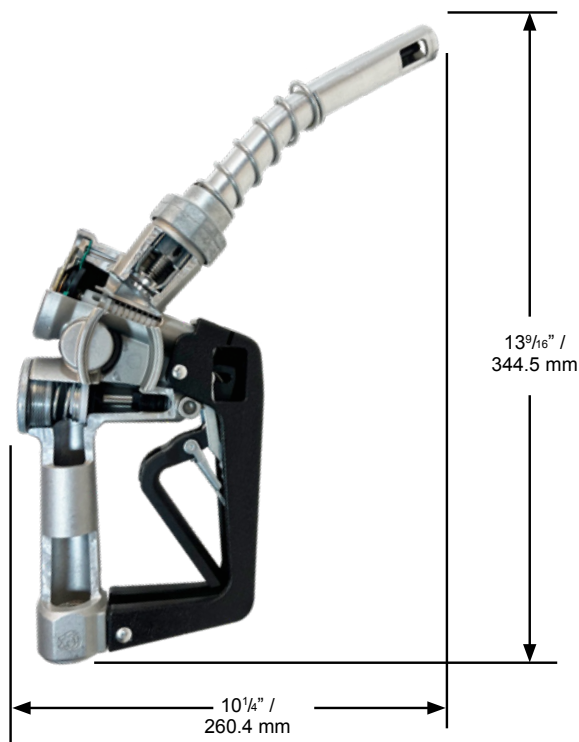

Construction

Body	Die cast aluminum with high-impact polymer handguard
Seals	Fluorocarbon
Packing	Double o-ring seal protected by fiber-reinforced Teflon [®]
Lever	One piece polymer
Inlet	3/4" (19 mm) NPT or 3/4" (19 mm) BSP

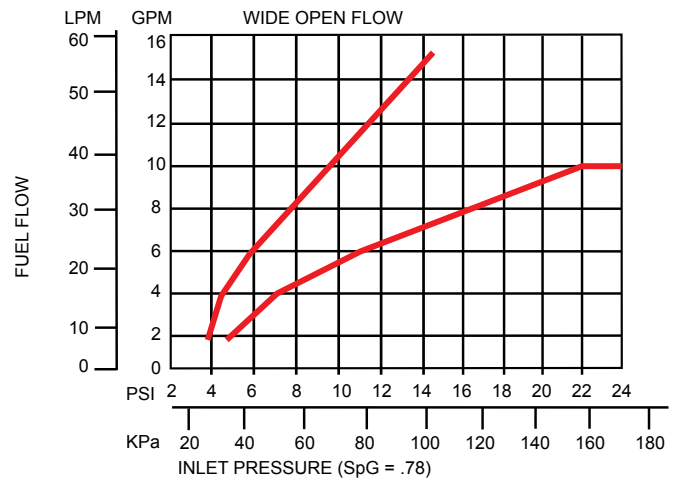

XS[®] E25 Nozzles

Pressure-activated, automatic shut-off nozzle for full-service and self-service stations.

Nozzle Options

Nozzle Guard Options



Waffle Guard Options



Handguard Options



Latch Plate Options

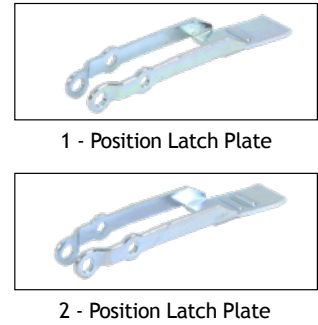

Lever Options

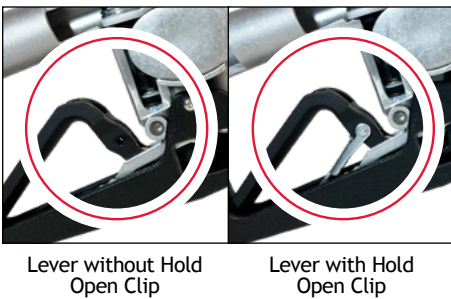

XS[®] E25 Nozzles

Pressure-activated, automatic shut-off nozzle for full-service and self-service stations.

System Options

Safe-T-Breaks[®]

MODEL NO.	DESCRIPTION
006273	3/4" F x 3/4" F Non-Reconnectable E85 Safe-T-Break [®]
006360 [^]	3/4" F x 3/4" F Reconnectable E25/E85 Safe-T-Break [®]

Spouts

MODEL NO.	DESCRIPTION
006207	Unleaded E85 Spout Assembly

Pressure/Vacuum Vents

MODEL NO.	DESCRIPTION
004620	2" Slip-On Pressure Vacuum Vent
004885	2" Thread-On Pressure Vacuum Vent - NPT
005885	2" Thread-On Pressure Vacuum Vent with Internal Screen - NPT

Accessories, Testing and Maintenance

MODEL NO.	DESCRIPTION
000397	Unleaded Spout Gauge
003593	Hold Open Clip Kit
007089	Nozzle Service Kit
007490	Internal Flo-Equalizer [®] - 10 gpm / 37.9 Lpm

















Swivels

MODEL NO.	DESCRIPTION
006350 [^]	3/4" M x 3/4" F NPT Multi-Plane E85 Swivel

Guards

MODEL NO.	DESCRIPTION
001506	Protection Package
001806	Full Grip Reguard
001807	Waffle Splash Guard with Small Hole
001808	Waffle Splash Guard
001809	Reguard Protection Package
003440	Mate Easy-On Package
003795	Mate Guard
004145	Full Grip Guard
006628	POPD [®] S Clear Cover
006665	POPD [®] S Full Grip Guard
007205	POPD [®] S Full Grip Reguard
007361	Black Handle Cover
007999	POPD [®] H Clear Cover
008165	POPD [®] S Mate Guard
008166	POPD [®] H Mate Guard
008175	POPD [®] EZS Nozzle Guard
008176	POPD [®] EZH Nozzle Guard
008185	POPD [®] H Full Grip Guard
008192	POPD [®] H Full Grip Reguard
014524	International Mate Package
014530	International Mate Guard
015247	International POPD [®] H Mate Guard
015253	International POPD [®] H Mate Package

Guard Color Chart

COLOR	SUFFIX	COLOR	SUFFIX	COLOR <i>CUSTOM</i>	SUFFIX
 Blue	-01	 Gold	-08	 Amoco Blue	-07 <i>CUSTOM</i>
 Red	-02	 Silver	-09	 Apple Green	-18 <i>CUSTOM</i>
 Green	-03	 BP Green	-16	 Purple	-19 <i>CUSTOM</i>
 Black	-04	 M Blue	-21	 Pink	-20 <i>CUSTOM</i>
 Yellow	-05	 Orange	-39	 BPS Green	-22 <i>CUSTOM</i>
 White	-06				

Scuff Guards are to be ordered with the corresponding guard color option added to the model number. Example: If BLUE guards are desired, add guard color option -01 to the model number (159504-01). For custom colors, a minimum order of 4,000 guards will be required.

X E85 Nozzles

Automatic shut-off nozzle for full-service and self-service stations.

- X E85 nozzle shuts off when the gas tank is full.
- Stainless steel reinforced spout bushing keeps spout tip round, and acts as a captive fastener to prevent tip-end sensor damage.
- Nozzle is equipped with a unique Flo-Stop® device that shuts off the nozzle if it falls from the fill neck or raises above the horizontal.
- StreamShaper® reduces turbulence for straighter fuel flow and less splash back spillage.
- Aluminum body, spout, and internal parts are nickel plated to prevent contamination and corrosion from Ethanol blends.
- New poppet seal design in conjunction with new tilt poppet design improves flow control (“to-the-penny” dispensing) and provides enhanced endurance over time.
- Optional cold weather seals are rated to -40° F/C.
- Optional Gilbarco, Tokheim, and Wayne handguards can be fitted with a magnet to trigger the dispenser’s proximity switch, or can be provided without the magnet for dispensers equipped with a standard “flapper” switch.
- All seals are UL approved fluorocarbon compounds to prevent degradation from Ethanol blends.
- Compatible with unleaded and all Ethanol blends through E-85
- Comes standard with smooth full grip guard
- ADA-compliant EZ Lever reduces the force required to open the main poppet valve by 50%, resulting in a lever operating force ≤5 lbs.



MODEL NO.
659404N

New Unleaded Nozzles with NPT Inlet

MODEL NO.	DESCRIPTION	SHIPPING WEIGHT LBS (KG)
659404N [^]	with Two Notch Hold Open Clip	2.9 (1.3)
659459N [^]	with Two Notch Hold Open Clip and 1808 Waffle Splash Guard	3.0 (1.4)
659495N [^]	with Two Notch Hold Open Clip, POPD® S and 1808 Waffle Splash Guard	3.0 (1.4)

[^] NOT LISTED



 WARNING: Cancer and Reproductive Harm - www.P65Warnings.ca.gov

X E85 Nozzles

Automatic shut-off nozzle for full-service and self-service stations.

Dimensions

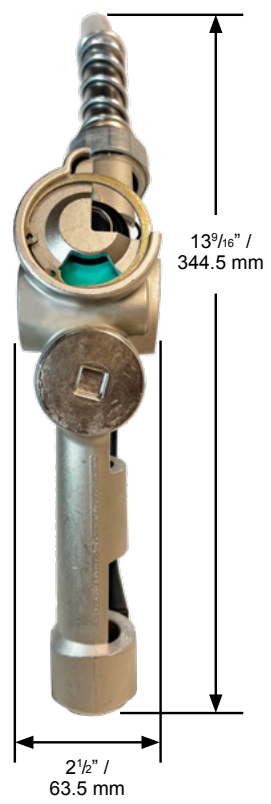
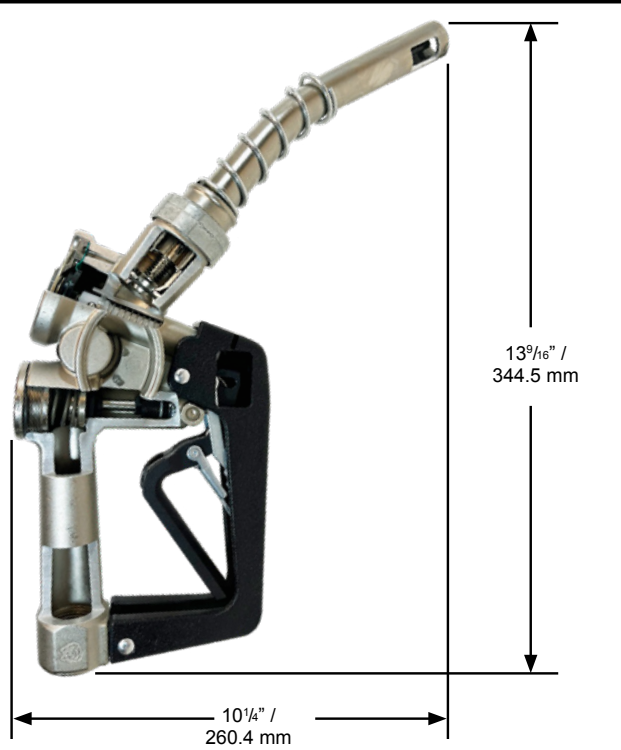

Construction

Body	Nickel-plated die cast aluminum with high-impact polymer handguard
Seals	Fluorocarbon
Packing	Double o-ring seal protected by fiber-reinforced Teflon®
Lever	Two piece polymer EZ Lever
Inlet	3/4" (19 mm) NPT or 3/4" (19 mm) BSP

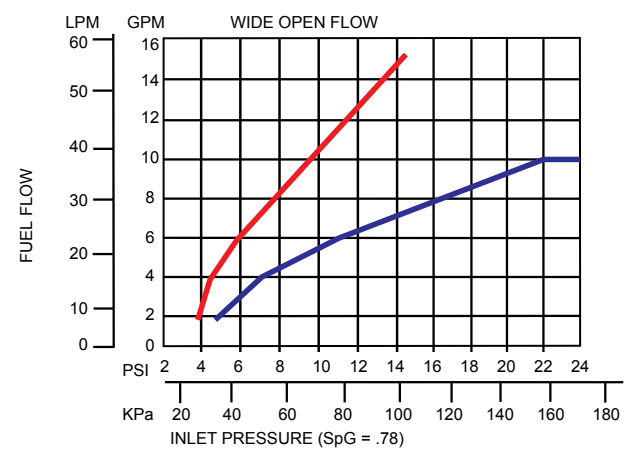

X E85 Nozzles

Automatic shut-off nozzle for full-service and self-service stations.

Nozzle Options

Nozzle Guard Options



Waffle Guard Options



Handguard Options

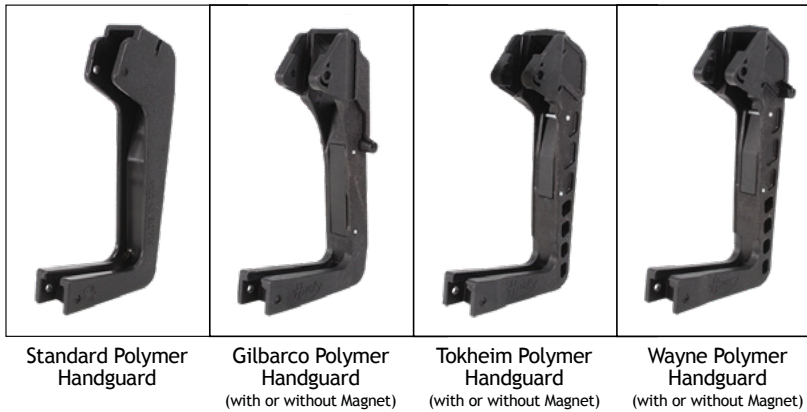

Latch Plate Options

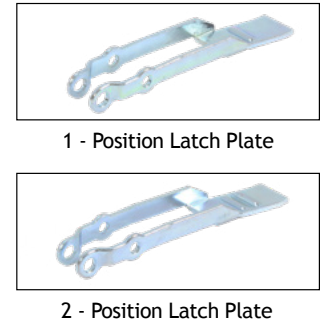

Lever Options

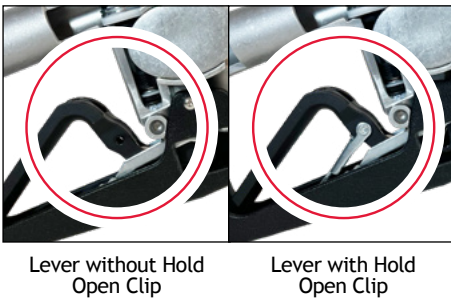

X E85 Nozzles

Automatic shut-off nozzle for full-service and self-service stations.

System Options

Safe-T-Breaks®

MODEL NO.	DESCRIPTION
006273	3/4" F x 3/4" F Non-Reconnectable E85 Safe-T-Break®
006360^	3/4" F x 3/4" F Reconnectable E25/E85 Safe-T-Break®

Spouts

MODEL NO.	DESCRIPTION
006207	Unleaded E85 Spout Assembly

Pressure/Vacuum Vents

MODEL NO.	DESCRIPTION
004620	2" Slip-On Pressure Vacuum Vent
004885	2" Thread-On Pressure Vacuum Vent - NPT
005885	2" Thread-On Pressure Vacuum Vent with Internal Screen - NPT

Accessories, Testing and Maintenance

MODEL NO.	DESCRIPTION
000397	Unleaded Spout Gauge
003593	Hold Open Clip Kit
007089	Nozzle Service Kit
007490	Internal Flo-Equalizer® - 10 gpm / 37.9 Lpm

Swivels

MODEL NO.	DESCRIPTION
006350^	3/4" M x 3/4" F NPT Multi-Plane E85 Swivel

Guards

MODEL NO.	DESCRIPTION
001506	Protection Package
001806	Full Grip Reguard
001807	Waffle Splash Guard with Small Hole
001808	Waffle Splash Guard
001809	Reguard Protection Package
003440	Mate Easy-On Package
003795	Mate Guard
004145	Full Grip Guard
006628	POPD® S Clear Cover
006665	POPD® S Full Grip Guard
007205	POPD® S Full Grip Reguard
007361	Black Handle Cover
007999	POPD® H Clear Cover
008165	POPD® S Mate Guard
008166	POPD® H Mate Guard
008175	POPD® EZS Nozzle Guard
008176	POPD® EZH Nozzle Guard
008185	POPD® H Full Grip Guard
008192	POPD® H Full Grip Reguard
014524	International Mate Package
014530	International Mate Guard
015247	International POPD® H Mate Guard
015253	International POPD® H Mate Package

Guard Color Chart

COLOR	SUFFIX	COLOR	SUFFIX	COLOR <i>CUSTOM</i>	SUFFIX
Blue	-01	Gold	-08	Amoco Blue	-07 <i>CUSTOM</i>
Red	-02	Silver	-09	Apple Green	-18 <i>CUSTOM</i>
Green	-03	BP Green	-16	Purple	-19 <i>CUSTOM</i>
Black	-04	M Blue	-21	Pink	-20 <i>CUSTOM</i>
Yellow	-05	Orange	-39	BPS Green	-22 <i>CUSTOM</i>
White	-06				

Scuff Guards are to be ordered with the corresponding guard color option added to the model number. Example: If BLUE guards are desired, add guard color option -01 to the model number (159504-01). For custom colors, a minimum order of 4,000 guards will be required.

XS[®] E85 Nozzles

CONVENTIONAL ETHANOL FUELING

Pressure-activated, automatic shut-off nozzle for full-service and self-service stations.

- XS E85 nozzle shuts off when:
 - the pump shuts off. –the gas tank is full
 - the lever is opened before the pump is turned on
 - the leak detector has not completed the test cycle
- Stainless steel reinforced spout bushing keeps spout tip round, and acts as a captive fastener to prevent tip-end sensor damage.
- Nozzle is equipped with a unique Flo-Stop[®] device that shuts off the nozzle if it falls from the fill neck or raises above the horizontal.
- *StreamShaper*[®] reduces turbulence for straighter fuel flow and less splash back spillage.
- Aluminum body, spout, and internal parts are nickel plated to prevent contamination and corrosion from Ethanol blends.
- New poppet seal design in conjunction with new tilt poppet design improves flow control (“to-the-penny” dispensing) and provides enhanced endurance over time.
- All seals are UL approved fluorocarbon compounds to prevent degradation from Ethanol blends.
- Compatible with unleaded and all Ethanol blends through E-85
- Comes standard with smooth full grip guard
- ADA-compliant EZ Lever reduces the force required to open the main poppet valve by 50%, resulting in a lever operating force ≤5 lbs.
- Optional cold weather seals are rated to -40° F/C.
- Optional Gilbarco, Tokheim, and Wayne handguards can be fitted with a magnet to trigger the dispenser’s proximity switch, or can be provided without the magnet for dispensers equipped with a standard “flapper” switch.



MODEL NO.
659504

New Unleaded Nozzles with NPT Inlet

MODEL NO.	DESCRIPTION	SHIPPING WEIGHT LBS (KG)
659504	with Two Notch Hold Open Clip	3.0 (1.4)
659559	with Two Notch Hold Open Clip and 1808 Waffle Splash Guard	3.1 (1.4)
659589	with Single Notch Hold Open Clip, POPD [®] S and 1808 Waffle Splash Guard	3.2 (1.5)
666164	with Two Notch Hold Open Clip, 1808 Waffle Splash Guard and Cold Weather Seals	3.1 (1.4)
6595179	with Single Notch Hold Open Clip and 1808 Waffle Splash Guard	3.1 (1.4)
E659504	with Two Notch Hold Open Clip and Mate Guard	3.0 (1.4)
E659559	with Two Notch Hold Open Clip, Mate Guard and 1808 Waffle Splash Guard	3.1 (1.4)
E659595	with Two Notch Hold Open Clip, POPD [®] S Mate Guard and 1808 Waffle Splash Guard	3.1 (1.5)

^ NOT LISTED



WARNING: Cancer and Reproductive Harm - www.P65Warnings.ca.gov

XS[®] E85 Nozzles

Pressure-activated, automatic shut-off nozzle for full-service and self-service stations.

Dimensions

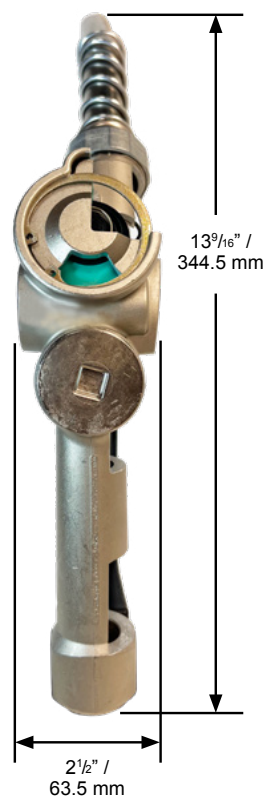
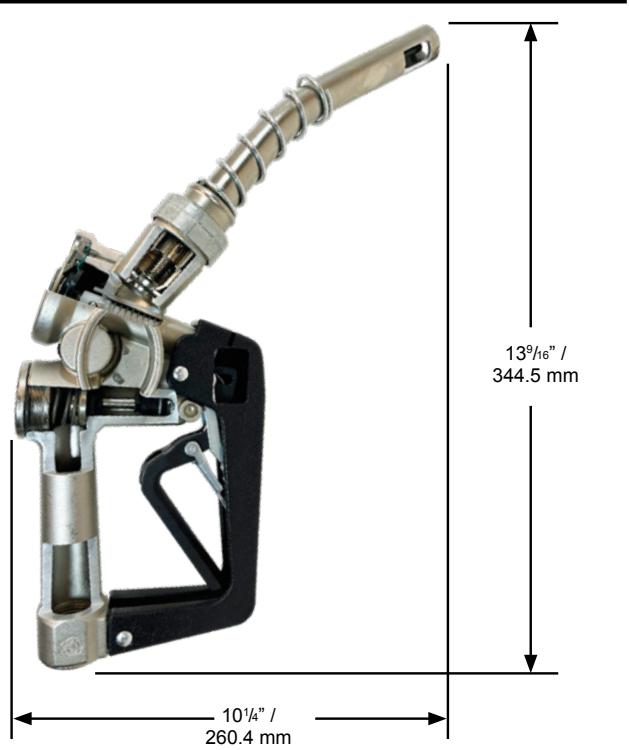

Construction

Body	Nickel-plated die cast aluminum with high-impact polymer handguard
Seals	Fluorocarbon
Packing	Double o-ring seal protected by fiber-reinforced Teflon [®]
Lever	Two piece polymer EZ Lever
Inlet	3/4" (19 mm) NPT or 3/4" (19 mm) BSP

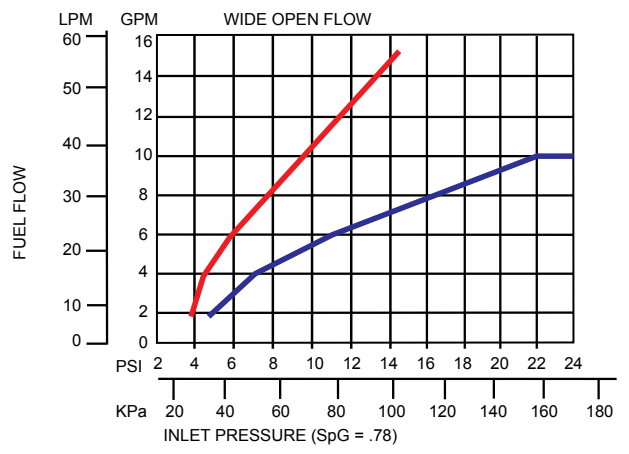

XS[®] E85 Nozzles

Pressure-activated, automatic shut-off nozzle for full-service and self-service stations.

Nozzle Options

Nozzle Guard Options



Waffle Guard Options



Handguard Options

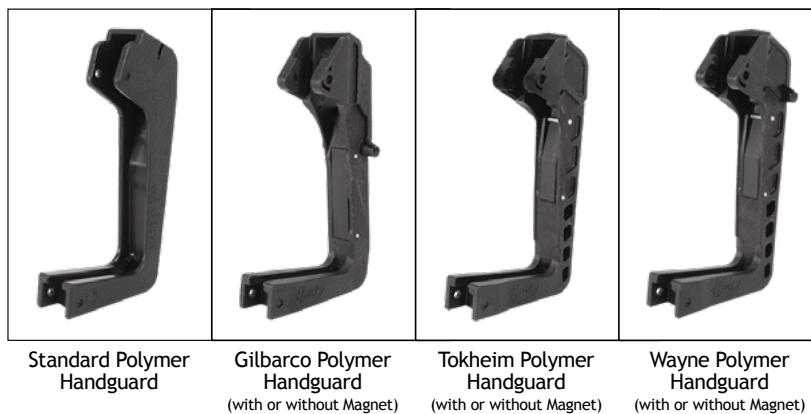

Latch Plate Options

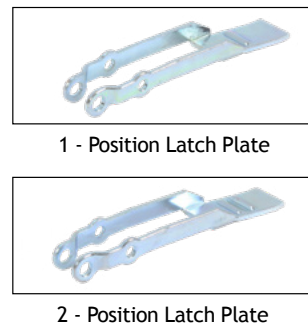

Lever Options

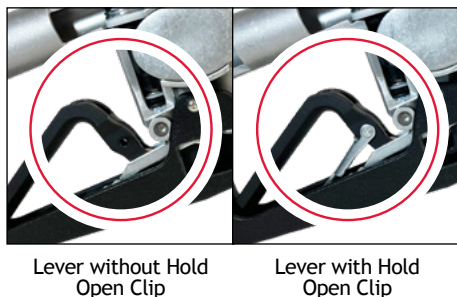

CONVENTIONAL ETHANOL FUELING

XS[®] E85 Nozzles

Pressure-activated, automatic shut-off nozzle for full-service and self-service stations.

System Options

Safe-T-Breaks[®]

MODEL NO.	DESCRIPTION
006273	3/4" F x 3/4" F Non-Reconnectable E85 Safe-T-Break [®]
006360 [^]	3/4" F x 3/4" F Reconnectable E25/E85 Safe-T-Break [®]

Spouts

MODEL NO.	DESCRIPTION
006207	Unleaded E85 Spout Assembly

Pressure/Vacuum Vents

MODEL NO.	DESCRIPTION
004620	2" Slip-On Pressure Vacuum Vent
004885	2" Thread-On Pressure Vacuum Vent - NPT
005885	2" Thread-On Pressure Vacuum Vent with Internal Screen - NPT

Accessories, Testing and Maintenance

MODEL NO.	DESCRIPTION
000397	Unleaded Spout Gauge
003593	Hold Open Clip Kit
007089	Nozzle Service Kit
007490	Internal Flo-Equalizer [®] - 10 gpm / 37.9 Lpm

Swivels

MODEL NO.	DESCRIPTION
006350 [^]	3/4" M x 3/4" F NPT Multi-Plane E85 Swivel

Guards

MODEL NO.	DESCRIPTION
001506	Protection Package
001806	Full Grip Reguard
001807	Waffle Splash Guard with Small Hole
001808	Waffle Splash Guard
001809	Reguard Protection Package
003440	Mate Easy-On Package
003795	Mate Guard
004145	Full Grip Guard
006628	POPD [®] S Clear Cover
006665	POPD [®] S Full Grip Guard
007205	POPD [®] S Full Grip Reguard
007361	Black Handle Cover
007999	POPD [®] H Clear Cover
008165	POPD [®] S Mate Guard
008166	POPD [®] H Mate Guard
008175	POPD [®] EZS Nozzle Guard
008176	POPD [®] EZH Nozzle Guard
008185	POPD [®] H Full Grip Guard
008192	POPD [®] H Full Grip Reguard
014524	International Mate Package
014530	International Mate Guard
015247	International POPD [®] H Mate Guard
015253	International POPD [®] H Mate Package

Guard Color Chart

COLOR	SUFFIX	COLOR	SUFFIX	COLOR <i>CUSTOM</i>	SUFFIX
Blue	-01	Gold	-08	Amoco Blue	-07 <i>CUSTOM</i>
Red	-02	Silver	-09	Apple Green	-18 <i>CUSTOM</i>
Green	-03	BP Green	-16	Purple	-19 <i>CUSTOM</i>
Black	-04	M Blue	-21	Pink	-20 <i>CUSTOM</i>
Yellow	-05	Orange	-39	BPS Green	-22 <i>CUSTOM</i>
White	-06				

Scuff Guards are to be ordered with the corresponding guard color option added to the model number. Example: If BLUE guards are desired, add guard color option -01 to the model number (159504-01). For custom colors, a minimum order of 4,000 guards will be required.



Vapor Recovery Nozzles

V34 Nozzles

Pressure-activated, automatic shut-off vacuum assist nozzle for full-service and self-service stations.

- V34 nozzle shuts off when:
 - the pump shuts off
 - the gas tank is full
 - the lever is opened before the pump is turned on
- the leak detector has not completed the test cycle
- Stainless steel reinforced spout bushing keeps spout tip round, and acts as a captive fastener to prevent tip-end sensor damage.
- Nozzle is equipped with a unique Flo-Stop® device that shuts off the nozzle if it falls from the fill neck or raises above the horizontal.
- *StreamShaper*® reduces turbulence for straighter fuel flow and less splash back spillage.
- Tilt poppet design provides precise “to-the-penny” dispensing.
- Strong vapor valve in the nozzle that is mechanically operated by the on-off action of the nozzle’s lever
- Husky® vapor return line is an internal part of the body casting, thus eliminating potential vapor leak points and fugitive evaporative emissions from the fuel remaining in the vapor path of the hose.
- Vapor assist achieved at the body end of the spout where a vapor ring catches emissions.
- Uses conventional unleaded spout with spout ring and soft vapor escape guard

- Nozzle comes standard with a full grip guard.
- Optional cold weather seals are rated to -40° F/C.
- Optional Gilbarco, Tokheim, and Wayne handguards can be fitted with a magnet to trigger the dispenser’s proximity switch, or can be provided without the magnet for dispensers equipped with a standard “flapper” switch.
- Optional vapor insert increases the vapor back pressure, closely matching that of the competition, and making installation a breeze, with little-to-no changes to the vacuum pump draw.
- Optional sightglass provides a clear window for the customer to view the fuel as it passes through the main poppet valve.
- ADA-compliant EZ Lever reduces the force required to open the main poppet valve by 50%, resulting in a lever operating force ≤5 lbs.



MODEL NO.
6250041

New Unleaded PHG Nozzles

MODEL NO.	DESCRIPTION	SHIPPING WEIGHT LBS (KG)
6250041	with Two Notch Hold Open Clip and Vapor Emissions Guard	3.3 (1.5)
6250431	with Single Notch Hold Open Clip and Vapor Emissions Guard	3.3 (1.5)
14373264N [^]	with Two Notch Hold Open Clip, Vapor Emissions Guard and RFID Spout	3.3 (1.5)

[^] NOT LISTED



WARNING: Cancer and Reproductive Harm - www.P65Warnings.ca.gov

V34 Nozzles

Pressure-activated, automatic shut-off vacuum assist nozzle for full-service and self-service stations.

Dimensions

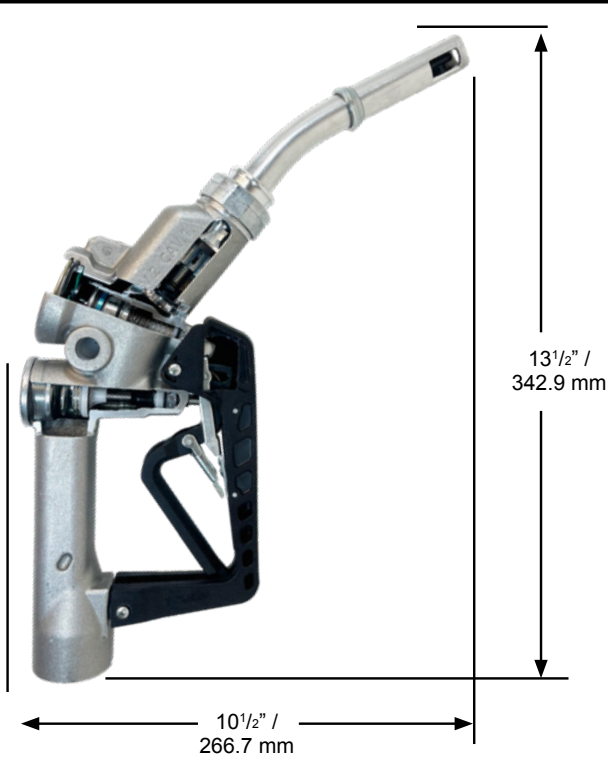

Construction

Body	One piece sand cast aluminum with high-impact polymer handguard
Seals	Fluorocarbon
Packing	Double o-ring seal protected by fiber-reinforced Teflon®
Lever	Two piece polymer EZ Lever
Inlet	M34 x 1.5mm

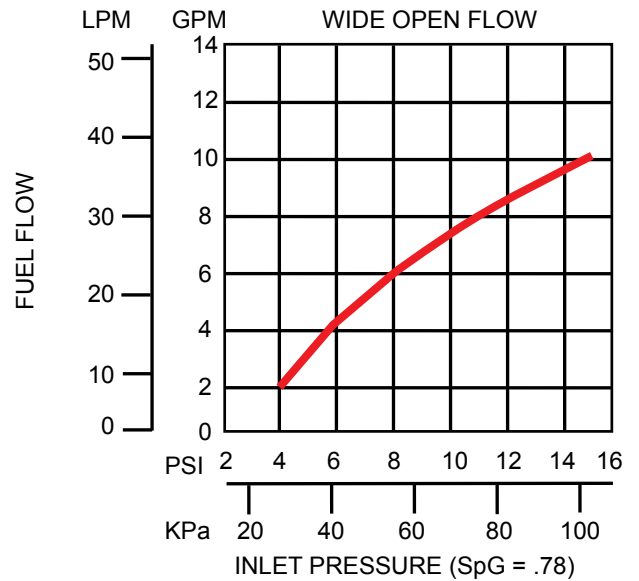
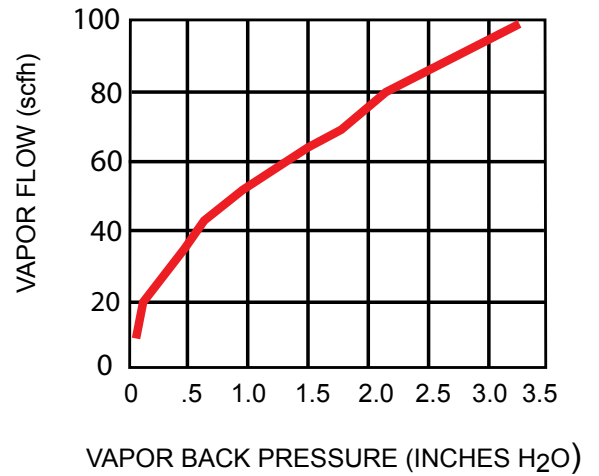

V34 Nozzles

Pressure-activated, automatic shut-off vacuum assist nozzle for full-service and self-service stations.

Nozzle Options

Nozzle Guard Options



Waffle Guard Options



1808 Waffle Guard

Handguard Options



Standard Polymer Handguard

Gilbarco Polymer Handguard
(with or without Magnet)

Tokheim Polymer Handguard
(with or without Magnet)

Wayne Polymer Handguard
(with or without Magnet)

Latch Plate Options

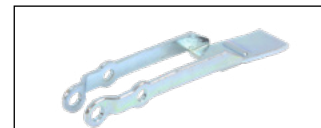

1 - Position Latch Plate



2 - Position Latch Plate

Lever Options

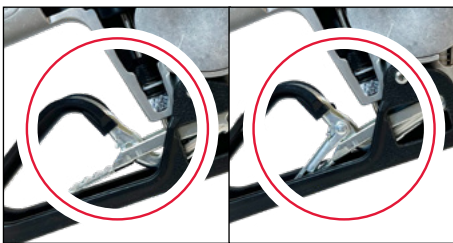

Lever without Hold Open Clip

Lever with Hold Open Clip

TUV Vapor Insert



07329

Sightglass Option



V34 Nozzles

Pressure-activated, automatic shut-off vacuum assist nozzle for full-service and self-service stations.

System Options

Safe-T-Breaks®

MODEL NO.	DESCRIPTION
004034	Reconnectable Safe-T-Break®
004034A*	Reconnectable Safe-T-Break® - Atex
005134A*	Non-Reconnectable Safe-T-Break® - Atex
006210	Non-Reconnectable Safe-T-Break®
008332	MAGBREAK® Coax M34 CK
010513	Non-Reconnectable Safe-T-Break® - Shearpin

Spouts

MODEL NO.	DESCRIPTION
006291	V34 Spout Assy Kit (Includes 004000 VSG and 006391 Spout Assembly)
006391	V34 Spout Assembly with Streamshaper®

Pressure/Vacuum Vents

MODEL NO.	DESCRIPTION
004620	2" Slip-On Pressure Vacuum Vent
004885	2" Thread-On Pressure Vacuum Vent - NPT
005885	2" Thread-On Pressure Vacuum Vent with Internal Screen - NPT

Accessories, Testing and Maintenance

MODEL NO.	DESCRIPTION
000397	Unleaded Spout Gauge
003593	Hold Open Clip Kit
004000	Vapor Splash Guard (VSG) with Clamp
004039	Vapor Splash Guard Clamp
004335	O-ring, Air / Liquid Test Spout Adaptor
004360	Air / Liquid Spout Adaptor
005233	O-ring Kit
005260	Tool for dry Air / Liquid Test
005837	Vapor Assist Flo-Equalizer®
006497	VSG Clamp Tool
006941	Hose Conversion Adaptor M34 x 1.5
007089	Nozzle Service Kit
010073	Waffle VSG with Clamp (single notch V34)
010076	Waffle VSG without Clamp (single notch V34)

Swivels

MODEL NO.	DESCRIPTION
004605	Multi-Plane Swivel
004605A*	Multi-Plane Swivel - Atex

Guards

MODEL NO.	DESCRIPTION
004231	Full Grip Reguard
005494	Lever Guard
006628	POPD® S Clear Cover
006660	POPD® S Full Grip Guard
006951	Full Grip Guard
007220	POPD® S Full Grip Reguard
007999	POPD® H Clear Cover
008184	POPD® H Full Grip Guard
008191	POPD® H Full Grip Reguard
010089	Black Handle Cover
014526	Mate Guard

Guard Color Chart

COLOR	SUFFIX	COLOR	SUFFIX	COLOR <i>CUSTOM</i>	SUFFIX
Blue	-01	Gold	-08	Amoco Blue	-07 <i>CUSTOM</i>
Red	-02	Silver	-09	Apple Green	-18 <i>CUSTOM</i>
Green	-03	BP Green	-16	Purple	-19 <i>CUSTOM</i>
Black	-04	M Blue	-21	Pink	-20 <i>CUSTOM</i>
Yellow	-05	Orange	-39	BPS Green	-22 <i>CUSTOM</i>
White	-06				

Scuff Guards are to be ordered with the corresponding guard color option added to the model number. Example: If BLUE guards are desired, add guard color option -01 to the model number (159504-01). For custom colors, a minimum order of 4,000 guards will be required.

V34 COAX Nozzles

Pressure-activated, automatic shut-off vacuum assist nozzle for full-service and self-service stations.

- V34 COAX nozzle shuts off when:
 - the pump shuts off
 - the gas tank is full
 - the lever is opened before the pump is turned on
 - the leak detector has not completed the test cycle
- Uses unleaded spout with spout ring, soft vapor splash guard and coaxial design that allows for fuel to be dispensed through the center of the spout while collecting vapors between the inner and outer spout tubes.
- Nozzle is equipped with a unique Flo-Stop® device that shuts off the nozzle if it falls from the fill neck or raises above the horizontal.
- Tilt poppet design provides precise “to-the-penny” dispensing.
- Strong vapor valve in the nozzle that is mechanically operated by the on-off action of the nozzle’s lever
- Husky® vapor return line is an internal part of the body casting, thus eliminating potential vapor leak points and fugitive evaporative emissions from the fuel remaining in the vapor path of the hose.
- Nozzle comes standard with a full grip guard.
- Optional cold weather seals are rated to -40° F/C.
- Optional Gilbarco, Tokheim, and Wayne handguards can be fitted with a magnet to trigger the dispenser’s proximity switch, or can be provided without the magnet for dispensers equipped with a standard “flapper” switch.
- Optional sightglass provides a clear window for the customer to view the fuel as it passes through the main poppet valve.
- ADA-compliant EZ Lever reduces the force required to open the main poppet valve by 50%, resulting in a lever operating force ≤5 lbs.

New Unleaded PHG Nozzles

MODEL NO.	DESCRIPTION	SHIPPING WEIGHT LBS (KG)
6200041	with Two Notch Hold Open Clip and Vapor Splash Guard	3.3 (1.5)
		[^] NOT LISTED



MODEL NO.
6200041



WARNING: Cancer and Reproductive Harm - www.P65Warnings.ca.gov

V34 COAX Nozzles

Pressure-activated, automatic shut-off vacuum assist nozzle for full-service and self-service stations.

Dimensions

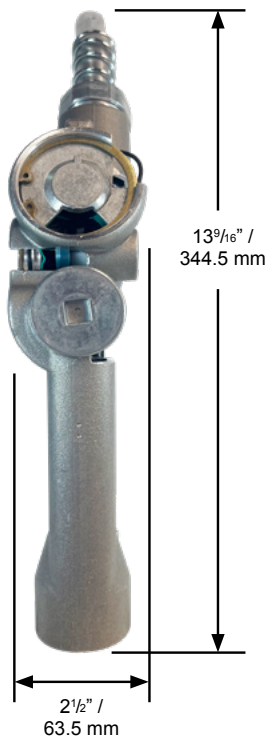
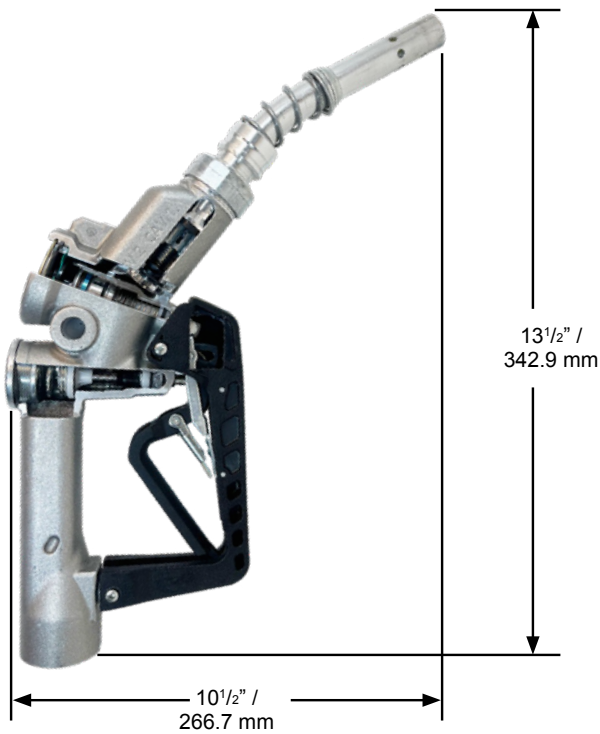

Construction

Body	One piece sand cast aluminum with high-impact polymer handguard
Seals	Fluorocarbon
Packing	Double o-ring seal protected by fiber-reinforced Teflon®
Lever	Two piece polymer EZ Lever
Inlet	M34 x 1.5mm

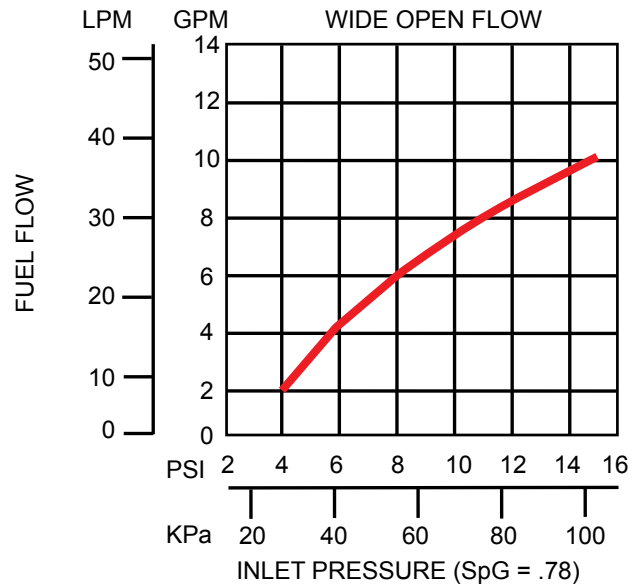
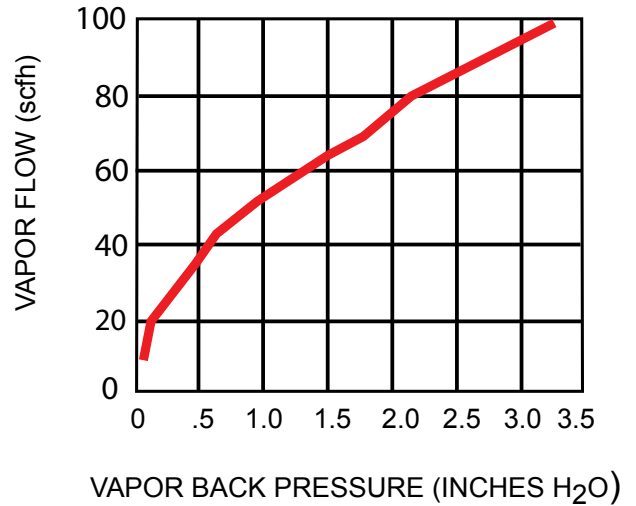

V34 COAX Nozzles

Pressure-activated, automatic shut-off vacuum assist nozzle for full-service and self-service stations.

Nozzle Options

Nozzle Guard Options



Handguard Options



Latch Plate Options

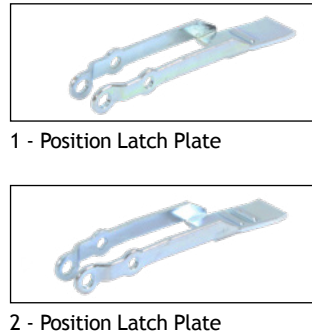

Lever Options

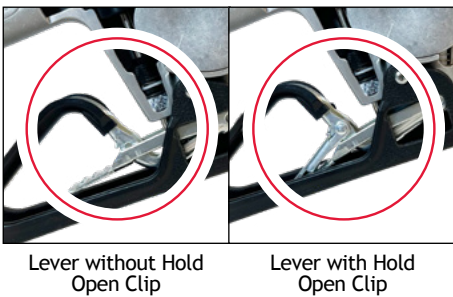

Sightglass Option



V34 COAX Nozzles

Pressure-activated, automatic shut-off vacuum assist nozzle for full-service and self-service stations.

System Options

Safe-T-Breaks®

MODEL NO.	DESCRIPTION
004034	Reconnectable Safe-T-Break®
004034A*	Reconnectable Safe-T-Break® - Atex
005134A*	Non-Reconnectable Safe-T-Break® - Atex
006210	Non-Reconnectable Safe-T-Break®
008332	MAGBREAK® Coax M34 CK
010513	Non-Reconnectable Safe-T-Break® - Shearpin

Spouts

MODEL NO.	DESCRIPTION
008642	V34-006200 Coaxial Spout Assembly Kit (Includes 009968 Spout Assembly and 004000 VSG)
009968	V34-006200 Coaxial Spout Assembly

Pressure/Vacuum Vents

MODEL NO.	DESCRIPTION
004620	2" Slip-On Pressure Vacuum Vent
004885	2" Thread-On Pressure Vacuum Vent - NPT
005885	2" Thread-On Pressure Vacuum Vent with Internal Screen - NPT

Accessories, Testing and Maintenance

MODEL NO.	DESCRIPTION
000397	Unleaded Spout Gauge
003593	Hold Open Clip Kit
004000	Vapor Splash Guard (VSG) with Clamp
004039	Vapor Splash Guard Clamp
004335	O-ring, Air / Liquid Test Spout Adaptor
004360	Air / Liquid Spout Adaptor
005233	O-ring Kit
005260	Tool for dry Air / Liquid Test
005837	Vapor Assist Flo-Equalizer®
006497	VSG Clamp Tool
006941	Hose Conversion Adaptor M34 x 1.5
007089	Nozzle Service Kit
010073	Waffle VSG with Clamp (single notch V34)
010076	Waffle VSG without Clamp (single notch V34)

Swivels

MODEL NO.	DESCRIPTION
004605	Multi-Plane Swivel
004605A*	Multi-Plane Swivel - Atex

Guards

MODEL NO.	DESCRIPTION
004231	Full Grip Reguard
005494	Lever Guard
006628	POPD® S Clear Cover
006660	POPD® S Full Grip Guard
006951	Full Grip Guard
007220	POPD® S Full Grip Reguard
007999	POPD® H Clear Cover
008184	POPD® H Full Grip Guard
008191	POPD® H Full Grip Reguard
010089	Black Handle Cover
014526	Mate Guard

Guard Color Chart

COLOR	SUFFIX	COLOR	SUFFIX	COLOR <i>CUSTOM</i>	SUFFIX
Blue	-01	Gold	-08	Amoco Blue	-07 <i>CUSTOM</i>
Red	-02	Silver	-09	Apple Green	-18 <i>CUSTOM</i>
Green	-03	BP Green	-16	Purple	-19 <i>CUSTOM</i>
Black	-04	M Blue	-21	Pink	-20 <i>CUSTOM</i>
Yellow	-05	Orange	-39	BPS Green	-22 <i>CUSTOM</i>
White	-06				

Scuff Guards are to be ordered with the corresponding guard color option added to the model number. Example: If BLUE guards are desired, add guard color option -01 to the model number (159504-01). For custom colors, a minimum order of 4,000 guards will be required.

V34 ORVR Nozzles

Pressure-activated, automatic shut-off vacuum assist nozzle for full-service and self-service stations.

- V34 ORVR nozzle shuts off when:
 - the pump shuts off
 - the gas tank is full
 - the lever is opened before the pump is turned on
 - the leak detector has not completed the test cycle
- Nozzle designed for the Veeder-Root® 900301 and VST Enviro-Loc® primary hose with ORVR valve
- Stainless steel reinforced spout bushing keeps spout tip round, and acts as a captive fastener to prevent tip-end sensor damage.
- Nozzle is equipped with a unique Flo-Stop® device that shuts off the nozzle if it falls from the fill neck or raises above the horizontal.
- *StreamShaper*® reduces turbulence for straighter fuel flow and less splash back spillage.
- Tilt poppet design provides precise “to-the-penny” dispensing.
- Strong vapor valve in the nozzle that is mechanically operated by the on-off action of the nozzle’s lever
- Husky® vapor return line is an internal part of the body casting, thus eliminating potential vapor leak points and fugitive evaporative emissions from the fuel remaining in the vapor path of the hose.
- Vapor assist achieved at the body end of the spout where a vapor ring catches emissions.
- Uses conventional unleaded spout with spout ring and soft vapor escape guard
- Nozzle comes standard with a full grip guard.
- Optional cold weather seals are rated to -40° F/C.
- Optional Gilbarco, Tokheim, and Wayne handguards can be fitted with a magnet to trigger the dispenser’s proximity switch, or can be provided without the magnet for dispensers equipped with a standard “flapper” switch.
- Optional vapor insert increases the vapor back pressure, closely matching that of the competition, and making installation a breeze, with little-to-no changes to the vacuum pump draw.
- Optional sightglass provides a clear window for the customer to view the fuel as it passes through the main poppet valve.
- ADA-compliant EZ Lever reduces the force required to open the main poppet valve by 50%, resulting in a lever operating force ≤5 lbs.



MODEL NO.
6536041

New Unleaded PHG Nozzles

MODEL NO.	DESCRIPTION	SHIPPING WEIGHT LBS (KG)
6536041	with Two Notch Hold Open Clip and Vapor Escape Guard	3.3 (1.5)
		[^] NOT LISTED

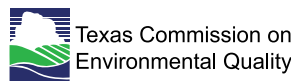

 WARNING: Cancer and Reproductive Harm - www.P65Warnings.ca.gov

V34 ORVR Nozzles

Pressure-activated, automatic shut-off vacuum assist nozzle for full-service and self-service stations.

Dimensions

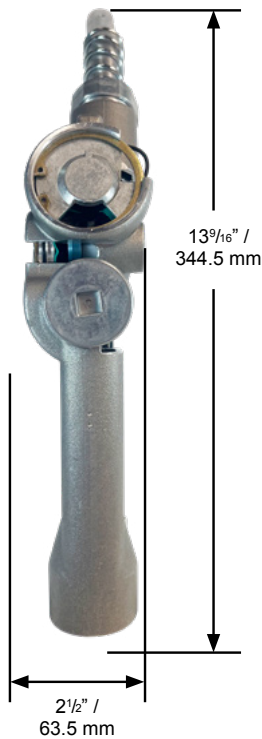
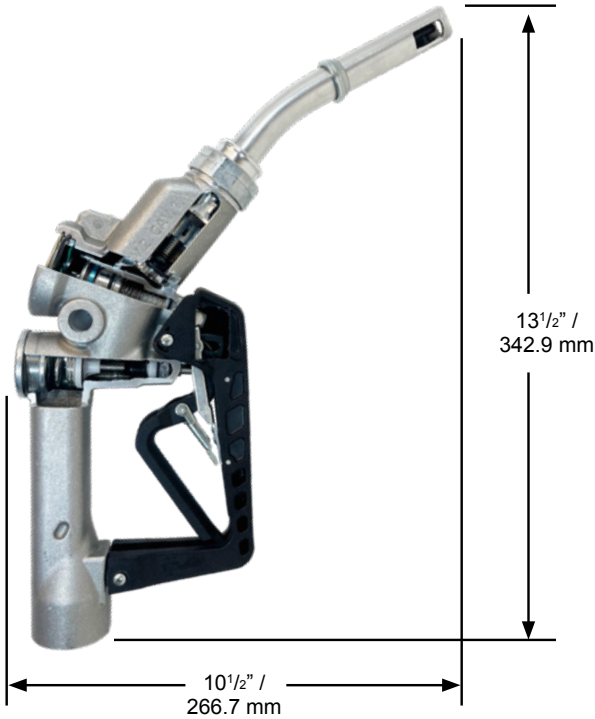

Construction

Body	One piece sand cast aluminum with high-impact polymer handguard
Seals	Fluorocarbon
Packing	Double o-ring seal protected by fiber-reinforced Teflon®
Lever	Two-piece polymer EZ Lever
Inlet	1-1/4" - 18 Unified (31.75 mm)

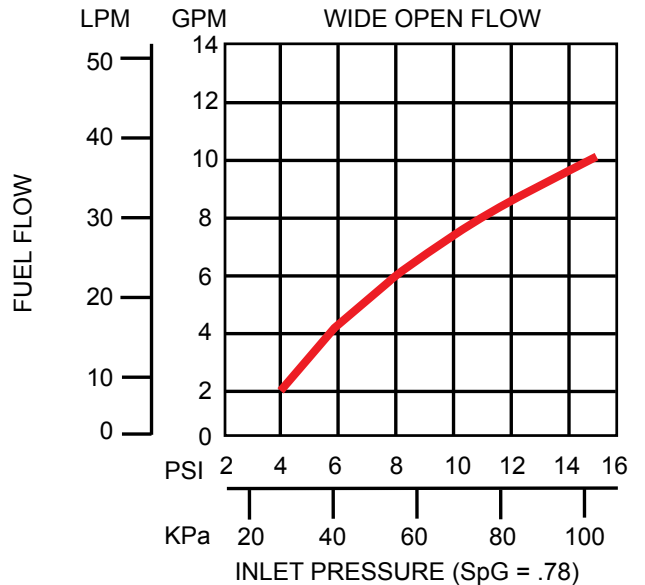
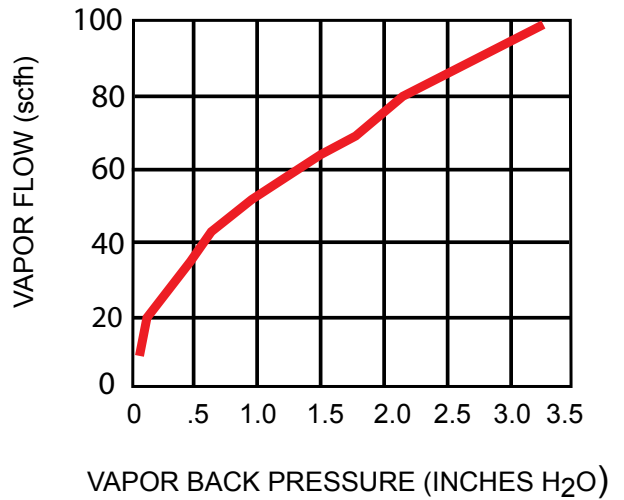

V34 ORVR **Nozzles**

Pressure-activated, automatic shut-off vacuum assist nozzle for full-service and self-service stations.

Nozzle Options

Nozzle Guard Options



Waffle Guard Options



1808 Waffle Guard

Handguard Options



Standard Polymer Handguard

Gilbarco Polymer Handguard
(with or without Magnet)

Tokheim Polymer Handguard
(with or without Magnet)

Wayne Polymer Handguard
(with or without Magnet)

Latch Plate Options

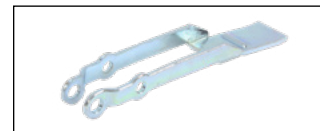

1 - Position Latch Plate



2 - Position Latch Plate

Lever Options



Lever without Hold Open Clip



Lever with Hold Open Clip

TUV Vapor Insert



07329

Sightglass Option



V34 ORVR Nozzles

Pressure-activated, automatic shut-off vacuum assist nozzle for full-service and self-service stations.

System Options

Safe-T-Breaks®

MODEL NO.	DESCRIPTION
006560	Reconnectable Safe-T-Break® for 1-1/4" THREADS
014592	MAGBREAK® Coax 1.25
015377	Non-reconnectable Safe-T-Break® 1-1/4"

Spouts

MODEL NO.	DESCRIPTION
006291	V34 Spout Assy Kit (Includes 004000 VSG and 006391 Spout Assembly)
006391	V34 Spout Assembly with Streamshaper®

Pressure/Vacuum Vents

MODEL NO.	DESCRIPTION
004620	2" Slip-On Pressure Vacuum Vent
004885	2" Thread-On Pressure Vacuum Vent - NPT
005885	2" Thread-On Pressure Vacuum Vent with Internal Screen - NPT

Accessories, Testing and Maintenance

MODEL NO.	DESCRIPTION
000397	Unleaded Spout Gauge
003593	Hold Open Clip Kit
004000	Vapor Splash Guard (VSG) with Clamp
004039	Vapor Splash Guard Clamp
004335	O-ring, Air / Liquid Test Spout Adaptor
004360	Air / Liquid Spout Adaptor
005233	O-ring Kit
005260	Tool for dry Air / Liquid Test
005837	Vapor Assist Flo-Equalizer®
006497	VSG Clamp Tool
006941	Hose Conversion Adaptor M34 x 1.5
007089	Nozzle Service Kit
010073	Waffle VSG with Clamp (single notch V34)
010076	Waffle VSG without Clamp (single notch V34)

Swivels

MODEL NO.	DESCRIPTION
014620	Multi-Plane Swivel, 1-1/4"

Guards

MODEL NO.	DESCRIPTION
004231	Full Grip Reguard
005494	Lever Guard
006628	POPD® S Clear Cover
006660	POPD® S Full Grip Guard
006951	Full Grip Guard
007220	POPD® S Full Grip Reguard
007999	POPD® H Clear Cover
008184	POPD® H Full Grip Guard
008191	POPD® H Full Grip Reguard
010089	Black Handle Cover
014526	Mate Guard

Guard Color Chart

COLOR	SUFFIX	COLOR	SUFFIX	COLOR <i>CUSTOM</i>	SUFFIX
Blue	-01	Gold	-08	Amoco Blue	-07 <i>CUSTOM</i>
Red	-02	Silver	-09	Apple Green	-18 <i>CUSTOM</i>
Green	-03	BP Green	-16	Purple	-19 <i>CUSTOM</i>
Black	-04	M Blue	-21	Pink	-20 <i>CUSTOM</i>
Yellow	-05	Orange	-39	BPS Green	-22 <i>CUSTOM</i>
White	-06				

Scuff Guards are to be ordered with the corresponding guard color option added to the model number. Example: If BLUE guards are desired, add guard color option -01 to the model number (159504-01). For custom colors, a minimum order of 4,000 guards will be required.

V34iS Nozzles

Pressure-activated, automatic shut-off vacuum assist nozzle for full-service and self-service stations.

- V34iS nozzle shuts off when:
 - the pump shuts off
 - the gas tank is full
 - the lever is opened before the pump is turned on
 - the leak detector has not completed the test cycle
- Stainless steel reinforced spout bushing keeps spout tip round, and acts as a captive fastener to prevent tip-end sensor damage.
- Nozzle is equipped with a unique Flo-Stop® device that shuts off the nozzle if it falls from the fill neck or raises above the horizontal.
- *StreamShaper*® reduces turbulence for straighter fuel flow and less splash back spillage.
- Tilt poppet design provides precise “to-the-penny” dispensing.
- Strong vapor valve in the nozzle that is mechanically operated by the on-off action of the nozzle’s lever
- Husky® vapor return line is an internal part of the body casting, thus eliminating potential vapor leak points and fugitive evaporative emissions from the fuel remaining in the vapor path of the hose.
- Vapor assist achieved at the body end of the spout where a vapor ring catches emissions.
- Uses international spout and aluminum vapor collector

- Nozzle comes standard with a full grip guard.
- Optional cold weather seals are rated to -40 °F/C.
- Optional Gilbarco, Tokheim, and Wayne handguards can be fitted with a magnet to trigger the dispenser’s proximity switch, or can be provided without the magnet for dispensers equipped with a standard “flapper” switch.
- Optional vapor insert increases the vapor back pressure, closely matching that of the competition, and making installation a breeze, with little-to-no changes to the vacuum pump draw.
- Optional sightglass provides a clear window for the customer to view the fuel as it passes through the main poppet valve.
- ADA-compliant EZ Lever reduces the force required to open the main poppet valve by 50%, resulting in a lever operating force ≤5 lbs.

New Unleaded PHG Nozzles

MODEL NO.	DESCRIPTION	SHIPPING WEIGHT LBS (KG)
E13177041N^	with Two Notch Hold Open Clip, Mate Guard and Gilbarco Magnetic Handguard	3.3 (1.5)
E13800106N^	with Two Notch Hold Open Clip, Mate Guard and Tokheim Magnetic Handguard	3.3 (1.5)
E13986223N^	with Two Notch Hold Open Clip, Mate Guard and Wayne Magnetic Handguard	3.3 (1.5)
E16588041N^	with Two Notch Hold Open Clip, Mate Guard and Wayne Magnetic Handguard	3.3 (1.5)

^ NOT LISTED



MODEL NO.
E15071041A*



II 1 G
EN 13012
Type 1



P-TU7-8113626964



WARNING: Cancer and Reproductive Harm - www.P65Warnings.ca.gov

V34iS Nozzles

Pressure-activated, automatic shut-off vacuum assist nozzle for full-service and self-service stations.

Dimensions

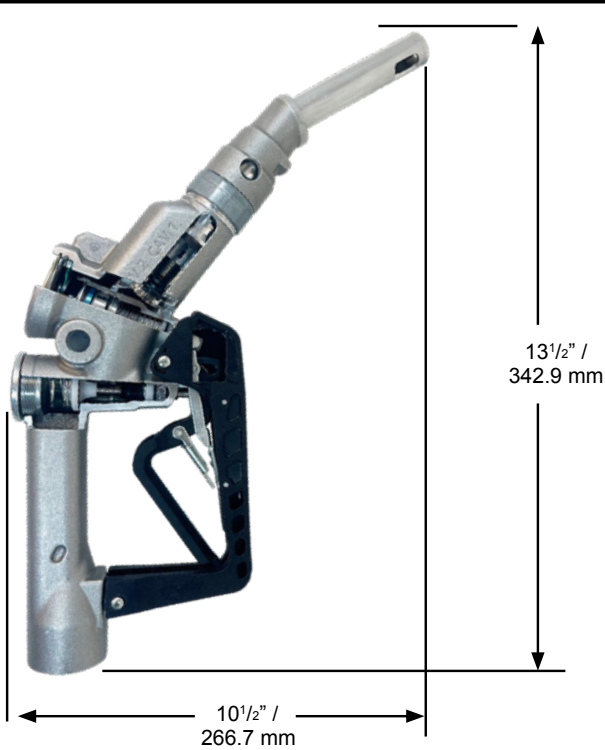

Construction

Body	One piece sand cast aluminum with high-impact polymer handguard
Seals	Fluorocarbon
Packing	Double o-ring seal protected by fiber-reinforced Teflon®
Lever	Two-piece polymer EZ Lever
Inlet	M34 x 1.5mm

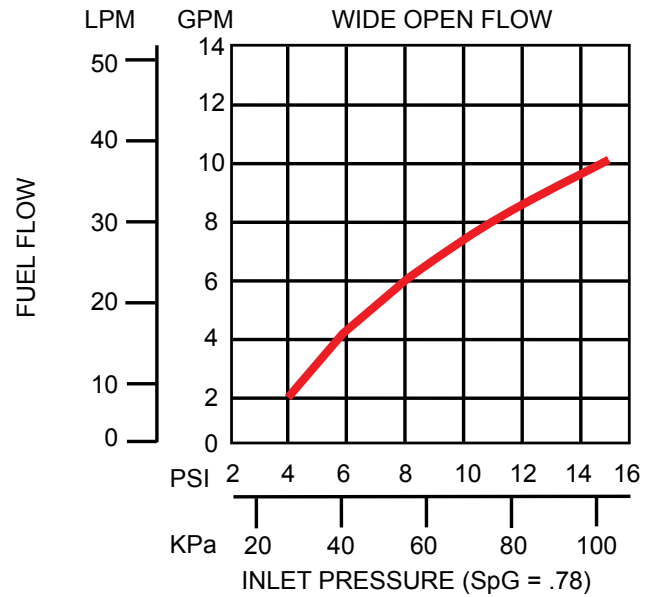
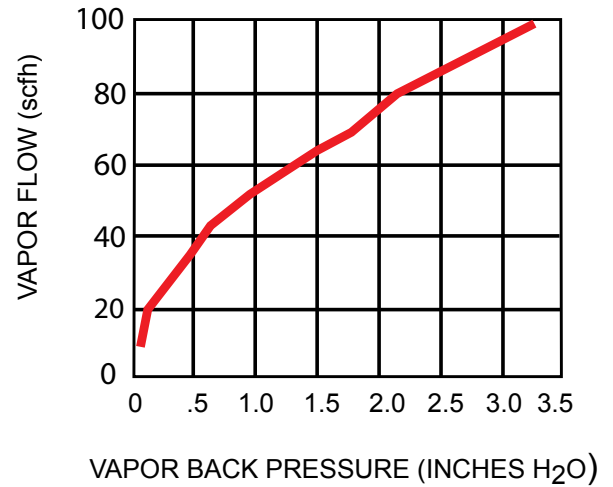

V34iS Nozzles

Pressure-activated, automatic shut-off vacuum assist nozzle for full-service and self-service stations.

Nozzle Options

Nozzle Guard Options



Waffle Guard Options



1808 Waffle Guard

Handguard Options



Standard Polymer Handguard Gilbarco Polymer Handguard (with or without Magnet) Tokheim Polymer Handguard (with or without Magnet) Wayne Polymer Handguard (with or without Magnet)

Latch Plate Options



1 - Position Latch Plate

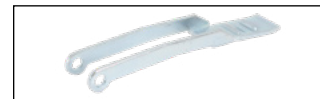

2 - Position Latch Plate

Lever Options



Lever without Hold Open Clip



Lever with Hold Open Clip

TUV Vapor Insert



07329

Sightglass Option



V34iS Nozzles

Pressure-activated, automatic shut-off vacuum assist nozzle for full-service and self-service stations.

System Options

Safe-T-Breaks®

MODEL NO.	DESCRIPTION
004034	Reconnectable Safe-T-Break®
004034A*	Reconnectable Safe-T-Break® - Atex
005134A*	Non-Reconnectable Safe-T-Break® - Atex
006210	Non-Reconnectable Safe-T-Break®
008332	MAGBREAK® Coax M34 CK
010513	Non-Reconnectable Safe-T-Break® - Shearpin

Spouts

MODEL NO.	DESCRIPTION
006291	V34 Spout Assy Kit (Includes 004000 VSG and 006391 Spout Assembly)
006391	V34 Spout Assembly with Streamshaper®

Pressure/Vacuum Vents

MODEL NO.	DESCRIPTION
004620	2" Slip-On Pressure Vacuum Vent
004885	2" Thread-On Pressure Vacuum Vent - NPT
005885	2" Thread-On Pressure Vacuum Vent with Internal Screen - NPT

Accessories, Testing and Maintenance

MODEL NO.	DESCRIPTION
000397	Unleaded Spout Gauge
003593	Hold Open Clip Kit
004335	O-ring, Air / Liquid Test Spout Adaptor
004360	Air / Liquid Spout Adaptor
005233	O-ring Kit
005260	Tool for dry Air / Liquid Test
005837	Vapor Assist Flo-Equalizer®
006941	Hose Conversion Adaptor M34 x 1.5
007089	Nozzle Service Kit

Swivels

MODEL NO.	DESCRIPTION
004605	Multi-Plane Swivel
004605A*	Multi-Plane Swivel - Atex

Guards

MODEL NO.	DESCRIPTION
004231	Full Grip Reguard
005494	Lever Guard
006628	POPD® S Clear Cover
006660	POPD® S Full Grip Guard
006951	Full Grip Guard
007220	POPD® S Full Grip Reguard
007999	POPD® H Clear Cover
008184	POPD® H Full Grip Guard
008191	POPD® H Full Grip Reguard
010089	Black Handle Cover
014526	Mate Guard

Guard Color Chart

COLOR	SUFFIX	COLOR	SUFFIX	COLOR <i>CUSTOM</i>	SUFFIX
Blue	-01	Gold	-08	Amoco Blue	-07 <i>CUSTOM</i>
Red	-02	Silver	-09	Apple Green	-18 <i>CUSTOM</i>
Green	-03	BP Green	-16	Purple	-19 <i>CUSTOM</i>
Black	-04	M Blue	-25	Pink	-20 <i>CUSTOM</i>
Yellow	-05	Orange	-21	BPS Green	-22 <i>CUSTOM</i>
White	-06				

Scuff Guards are to be ordered with the corresponding guard color option added to the model number. Example: If BLUE guards are desired, add guard color option -01 to the model number (159504-01). For custom colors, a minimum order of 4,000 guards will be required.



GENERAL FUELING PRODUCTS

Distilled Spirits Dispensing

SST WN Nozzles

Automatic shut-off nozzle for wine and distilled spirits dispensing.

- SST WN nozzle shuts off when the container is full.
- Stainless steel construction
- Modular design for easy cleaning
- Constructed with food grade materials
- Seals provide maximum durability and chemical resistance to high concentrations of ethanols.
- Comes standard with mate guard and black polymer handle cover



MODEL NO.
E8528104N^

New Nozzles with BSP Inlet

MODEL NO.	DESCRIPTION	SHIPPING WEIGHT LBS (KG)
E8528104N^	with Two Notch Hold Open Clip, Mate Guard and Polymer Handle Cover	4.6 (2.1)
^ NOT LISTED		

New Nozzles without Inlet Threads

MODEL NO.	DESCRIPTION	SHIPPING WEIGHT LBS (KG)
E8528289N^	without Inlet Threads, with Two Notch Hold Open Clip, Mate Guard and Polymer Handle Cover	4.7 (2.1)
^ NOT LISTED		



 WARNING: Cancer and Reproductive Harm - www.P65Warnings.ca.gov

SST WN Nozzles

Automatic shut-off nozzle for wine and distilled spirits dispensing.

Dimensions

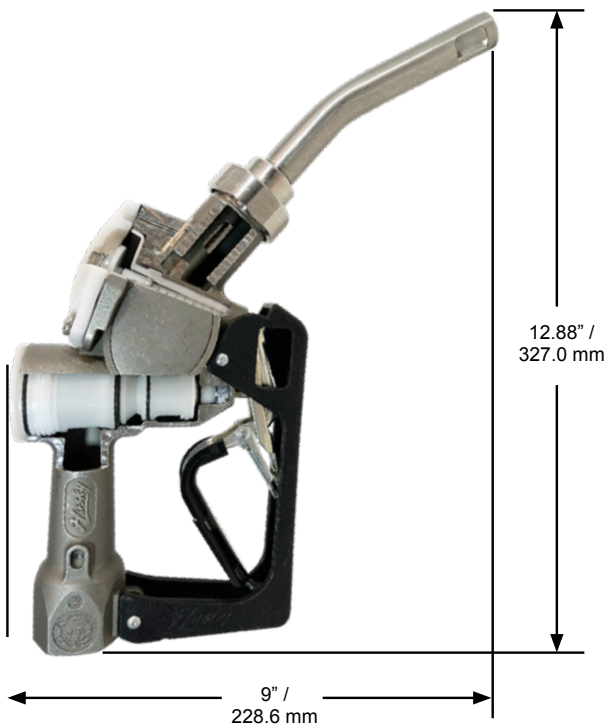

Construction

Body	Investment cast stainless steel with high-impact polymer handguard
Seals	Ethylene Propylene
Packing	Double o-ring seal protected by fiber reinforced Teflon®
Lever	One piece contoured steel with hard plastic cover
Inlet	1" / 25.4 mm BSPP or M34 x 1.5 mm

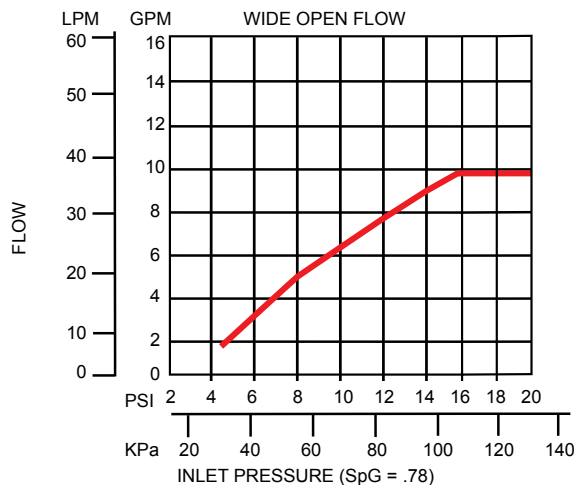

SST WN **Nozzles**

Automatic shut-off nozzle for wine and distilled spirits dispensing.

Nozzle Options

Nozzle Guard Options



Full Grip Guard

Mate Guard

Lever Options

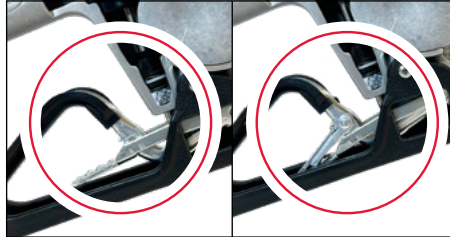

Lever without Hold
Open Clip

Lever with Hold
Open Clip

Latch Plate Options

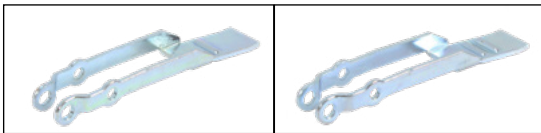

1 - Position Latch Plate

2 - Position Latch Plate

SST WN Nozzles

Automatic shut-off nozzle for wine and distilled spirits dispensing.

System Options

Swivels

MODEL NO.	DESCRIPTION
007269	1" M x 1" M BSPP Inline Swivel
007467	1" F x 1" M BSPP Inline Swivel

Spouts

MODEL NO.	DESCRIPTION
007362	with Flo-Stop®

















Guards

MODEL NO.	DESCRIPTION
000226	Mate Nozzle Guard
000554	Full Grip Guard
005494	Lever Guard
007295	Mate Handle Guard

Accessories, Testing and Maintenance

MODEL NO.	DESCRIPTION
007523	1" BSPP Seal Kit Assembly

Guard Color Chart

COLOR	SUFFIX	COLOR	SUFFIX	COLOR <i>CUSTOM</i>	SUFFIX
 Blue	-01	 Gold	-08	 Amoco Blue	-07 <i>CUSTOM</i>
 Red	-02	 Silver	-09	 Apple Green	-18 <i>CUSTOM</i>
 Green	-03	 BP Green	-16	 Purple	-19 <i>CUSTOM</i>
 Black	-04	 M Blue	-21	 Pink	-20 <i>CUSTOM</i>
 Yellow	-05	 Orange	-39	 BPS Green	-22 <i>CUSTOM</i>
 White	-06				

Scuff Guards are to be ordered with the corresponding guard color option added to the model number.
 Example: If BLUE guards are desired, add guard color option -01 to the model number (159504-01).
 For custom colors, a minimum order of 4,000 guards will be required.

X WN Nozzles

Automatic shut-off nozzle for distilled spirits dispensing.

- X WN nozzle shuts off when the container is full.
- Stainless steel reinforced spout bushing keeps spout tip round, and acts as a captive fastener to prevent tip-end sensor damage.
- *StreamShaper*[®] reduces turbulence for straighter fuel flow and less splash back spillage.
- Aluminum body, spout, and internal parts are nickel plated to prevent contamination and corrosion.
- Seals provide maximum durability and chemical resistance to higher concentrations of ethanol.
- Comes standard with a mate guard and black plastic handle cover
- ADA-compliant EZ Lever reduces the force required to open the main poppet valve by 50%, resulting in a lever operating force ≤5 lbs.



MODEL NO.
E840004N[^]

New Nozzles with NPT Inlet

MODEL NO.	DESCRIPTION	SHIPPING WEIGHT LBS (KG)
E840004N [^]	with Two Notch Hold Open Clip, Mate Guard and Polymer Handle Cover	2.8 (1.2)
		[^] NOT LISTED

New Nozzles wit BSP Threads

MODEL NO.	DESCRIPTION	SHIPPING WEIGHT LBS (KG)
E840016N [^]	with Two Notch Hold Open Clip, Mate Guard and Polymer Handle Cover	2.8 (1.2)
		[^] NOT LISTED



 WARNING: Cancer and Reproductive Harm - www.P65Warnings.ca.gov

X WN Nozzles

Automatic shut-off nozzle for distilled spirits dispensing.

Dimensions

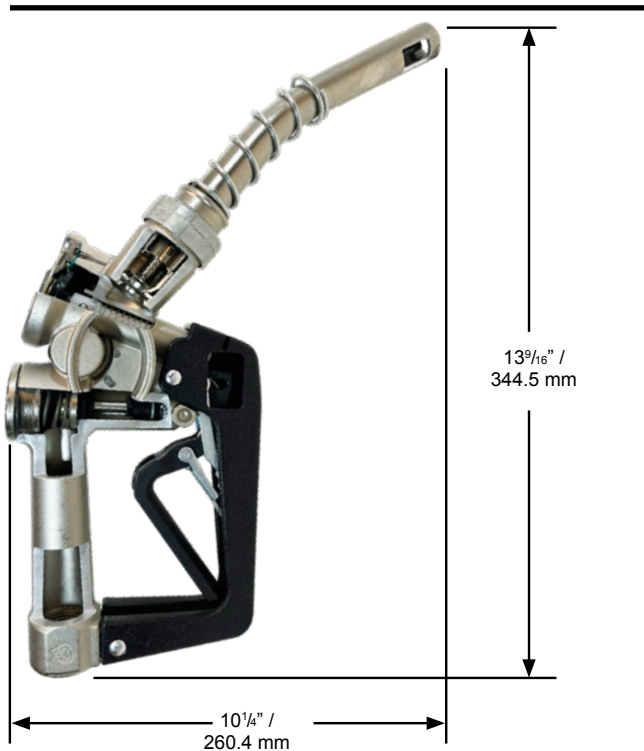

Construction

Body	Nickel-plated die cast aluminum with high-impact polymer handguard
Seals	Fluorocarbon
Packing	Double o-ring seal protected by fiber-reinforced Teflon®
Lever	Two piece polymer EZ Lever
Inlet	3/4" (19 mm) NPT or 3/4" (19 mm) BSP

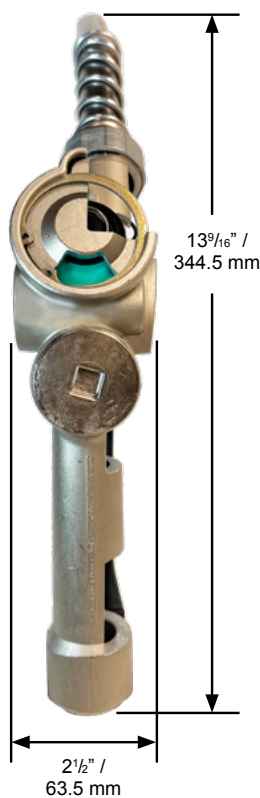
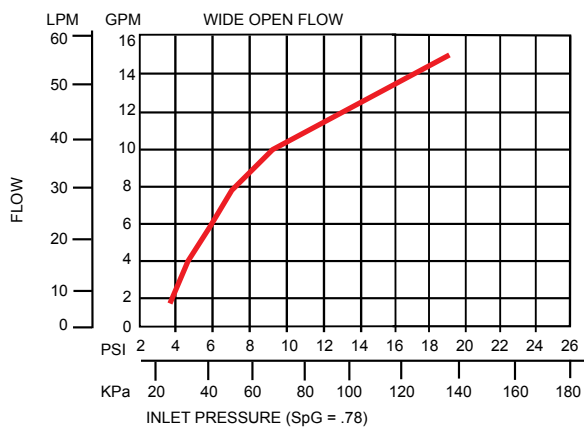

X WN Nozzles

Automatic shut-off nozzle for distilled spirits dispensing.

Nozzle Options

Nozzle Guard Options



Full Grip Guard

Mate Guard

Lever Options

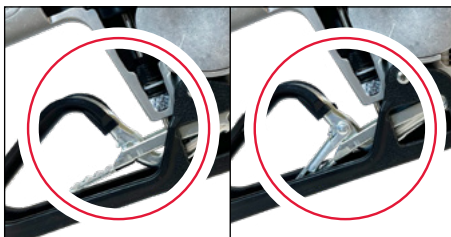

Lever without Hold
Open Clip

Lever with Hold
Open Clip

Latch Plate Options

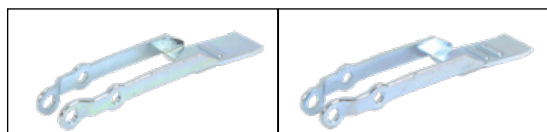

1 - Position Latch Plate

2 - Position Latch Plate

X WN Nozzles

Automatic shut-off nozzle for distilled spirits dispensing.

System Options

Swivels

MODEL NO.	DESCRIPTION
006350^	3/4" M x 3/4" F NPT Multi-Plane E85 Swivel

















Spouts

MODEL NO.	DESCRIPTION
006207	Unleaded E85 Spout Assembly

Guards

MODEL NO.	DESCRIPTION
003440	Mate Easy-On Package
003795	Mate Guard
004145	Full Grip Guard
007361	Black Handle Cover

Guard Color Chart

COLOR	SUFFIX	COLOR	SUFFIX	COLOR <i>CUSTOM</i>	SUFFIX
 Blue	-01	 Gold	-08	 Amoco Blue	-07 <i>CUSTOM</i>
 Red	-02	 Silver	-09	 Apple Green	-18 <i>CUSTOM</i>
 Green	-03	 BP Green	-16	 Purple	-19 <i>CUSTOM</i>
 Black	-04	 M Blue	-21	 Pink	-20 <i>CUSTOM</i>
 Yellow	-05	 Orange	-39	 BPS Green	-22 <i>CUSTOM</i>
 White	-06				

Scuff Guards are to be ordered with the corresponding guard color option added to the model number. Example: If BLUE guards are desired, add guard color option -01 to the model number (159504-01). For custom colors, a minimum order of 4,000 guards will be required.

1A WN Nozzles

Automatic shut-off nozzle for distilled spirits dispensing.

- 1A WN nozzle shuts off when the container is full.
- Stainless steel reinforced spout bushing keeps spout tip round, and acts as a captive fastener to prevent tip-end sensor damage.
- *StreamShaper*[®] reduces turbulence for straighter flow and less splash back spillage.
- Aluminum body, spout, and internal parts are nickel plated to prevent contamination and corrosion.
- Seals provide maximum durability and chemical resistance to higher concentrations of ethanol.
- Comes standard with a mate guard and black plastic handle cover
- ADA-compliant EZ Lever reduces the force required to open the main poppet valve by 50%, resulting in a lever operating force ≤5 lbs.



MODEL NO.
E874203N^

New Nozzles with NPT Inlet

MODEL NO.	DESCRIPTION	SHIPPING WEIGHT LBS (KG)
E874203N^	with Two Notch Hold Open Clip, Mate Guard and Polymer Handle Cover	3.3 (1.4)

^ NOT LISTED

New Nozzles with BSP Threads

MODEL NO.	DESCRIPTION	SHIPPING WEIGHT LBS (KG)
E874215N^	with Two Notch Hold Open Clip, Mate Guard and Polymer Handle Cover	3.3 (1.4)

^ NOT LISTED



 WARNING: Cancer and Reproductive Harm - www.P65Warnings.ca.gov

1A WN Nozzles

Automatic shut-off nozzle for distilled spirits dispensing.

Dimensions

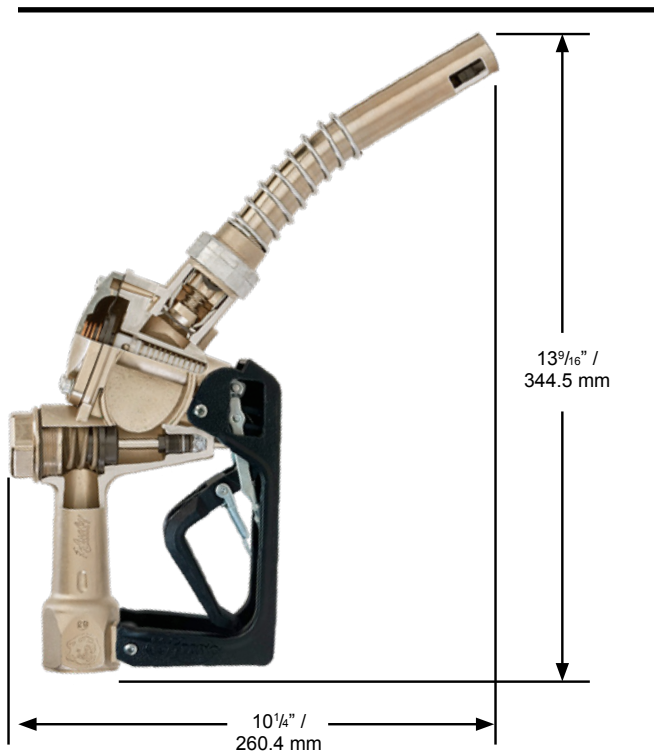

Construction

Body	Nickel-plated die cast aluminum with high-impact polymer handguard
Seals	Fluorocarbon
Packing	Double o-ring seal protected by fiber-reinforced Teflon®
Lever	Two piece polymer EZ Lever
Inlet	1" (25.4 mm) NPT or 1" (25.4 mm) BSP

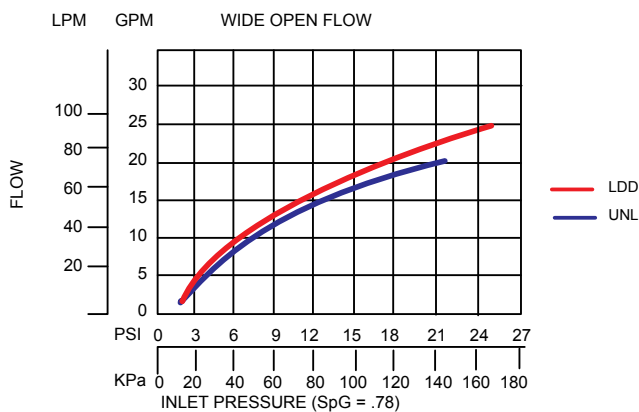

1A WN Nozzles

Automatic shut-off nozzle for distilled spirits dispensing.

Nozzle Options

Nozzle Guard Options



Full Grip Guard

Mate Guard

Lever Options

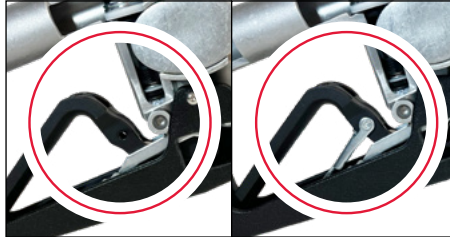

Lever without Hold
Open Clip

Lever with Hold
Open Clip

Latch Plate Options

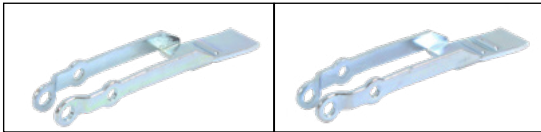

1 - Position Latch Plate

2 - Position Latch Plate

1A WN Nozzles

















Automatic shut-off nozzle for distilled spirits dispensing.

System Options

Guards

MODEL NO.	DESCRIPTION
000226	Mate Nozzle Guard
000554	Full Grip Guard
005494	Lever Guard
007295	Mate Handle Guard

Guard Color Chart

COLOR	SUFFIX	COLOR	SUFFIX	COLOR <i>CUSTOM</i>	SUFFIX
 Blue	-01	 Gold	-08	 Amoco Blue	-07 <i>CUSTOM</i>
 Red	-02	 Silver	-09	 Apple Green	-18 <i>CUSTOM</i>
 Green	-03	 BP Green	-16	 Purple	-19 <i>CUSTOM</i>
 Black	-04	 M Blue	-21	 Pink	-20 <i>CUSTOM</i>
 Yellow	-05	 Orange	-39	 BPS Green	-22 <i>CUSTOM</i>
 White	-06				

Scuff Guards are to be ordered with the corresponding guard color option added to the model number.
Example: If BLUE guards are desired, add guard color option -01 to the model number (159504-01).
 For custom colors, a minimum order of 4,000 guards will be required.

VIII WN Nozzles

High-Flow automatic shut-off nozzle for distilled spirits dispensing.

- VIII WN nozzle shuts off when the container is full.
- Dual poppet design equalizes pressure on both sides of the main poppet valve in order to aid in lifting the lever, and opening the main poppet valve for full flow.
- *StreamShaper*® reduces turbulence for straighter fuel flow and less splash back spillage.
- Aluminum body, spout, and internal parts are nickel plated to prevent contamination and corrosion.
- Seals provide maximum durability and chemical resistance to higher concentrations of ethanol.
- Strong flow (up to 75 gpm/ 283.9 Lpm)
- Comes standard with a full grip guard



MODEL NO.
874110N^

New Nozzle with NPT Inlet

MODEL NO.	DESCRIPTION	SHIPPING WEIGHT LBS (KG)
874110N^	with Three Notch Hold Open Clip, without Spout Bushing	3.9 (1.7)
		^ NOT LISTED

New Nozzle with BSP Inlet

MODEL NO.	DESCRIPTION	SHIPPING WEIGHT LBS (KG)
874138N^	with Three Notch Hold Open Clip, without Spout Bushing	3.9 (1.7)
		^ NOT LISTED



WARNING: Cancer and Reproductive Harm - www.P65Warnings.ca.gov

VIII WN Nozzles

High-Flow automatic shut-off nozzle for distilled spirits dispensing.

Dimensions

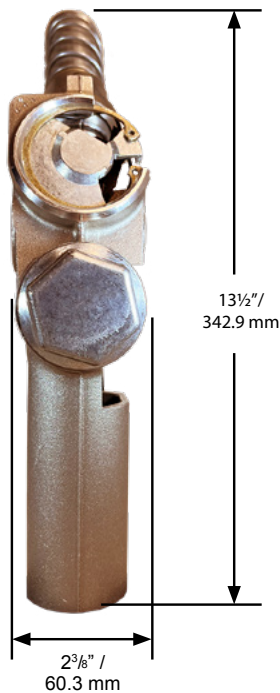
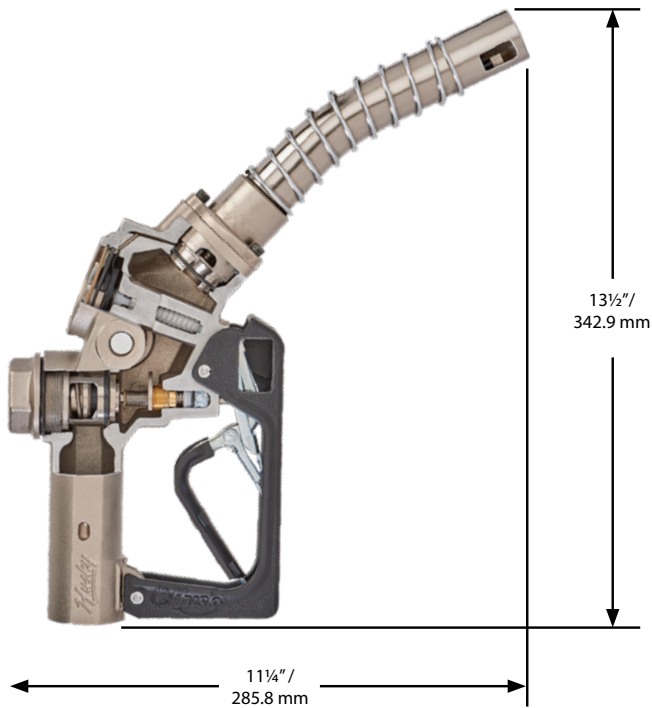

Construction

Body	Nickel-plated sand cast aluminum with high-impact polymer handguard
Seals	Fluorocarbon
Packing	Double o-ring seal protected by fiber-reinforced Teflon®
Lever	One piece contoured steel with hard polymer lever cover
Inlet	1" (25.4 mm) NPT or 1" (25.4 mm) BSP

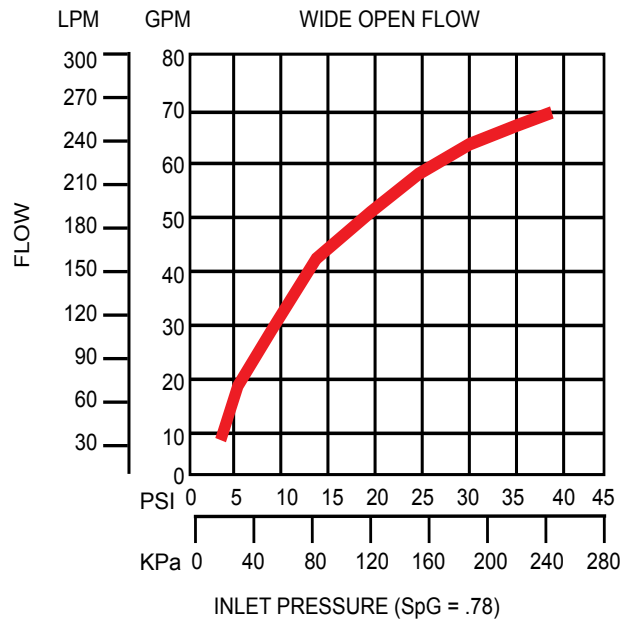

VIII WN **Nozzles**

High-Flow automatic shut-off nozzle for distilled spirits dispensing.

Nozzle Options

Nozzle Guard Options



Full Grip Guard

Lever Options

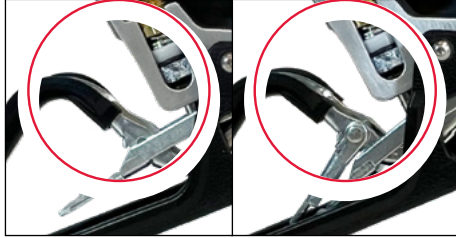

Lever without Hold
Open Clip

Lever with Hold
Open Clip

Latch Plate Options

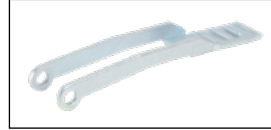

3 - Position Latch Plate

VIII WN **Nozzles**

















High-Flow automatic shut-off nozzle for distilled spirits dispensing.

System Options

Guards

MODEL NO.	DESCRIPTION
000554	Full Grip Guard
005494	Lever Guard

Guard Color Chart

COLOR	SUFFIX	COLOR	SUFFIX	COLOR <i>CUSTOM</i>	SUFFIX
 Blue	-01	 Gold	-08	 Amoco Blue	-07 <i>CUSTOM</i>
 Red	-02	 Silver	-09	 Apple Green	-18 <i>CUSTOM</i>
 Green	-03	 BP Green	-16	 Purple	-19 <i>CUSTOM</i>
 Black	-04	 M Blue	-25	 Pink	-20 <i>CUSTOM</i>
 Yellow	-05	 Orange	-39	 BPS Green	-22 <i>CUSTOM</i>
 White	-06				

Scuff Guards are to be ordered with the corresponding guard color option added to the model number.
 Example: If BLUE guards are desired, add guard color option -01 to the model number (159504-01).
 For custom colors, a minimum order of 4,000 guards will be required.

1690 WN Nozzles

Extreme High-Flow automatic shut-off nozzle for distilled spirits dispensing.

- 1690 WN nozzle shuts off when the container is full.
- Nozzle is equipped with two-position hold open latch.
- Dual poppet design equalizes pressure on both sides of the main poppet valve in order to aid in lifting the lever, and opening the main poppet valve for full flow.
- Design includes a self-adjusting stem packing.
- Right angle design allows nozzle to “fit” close to walls and corners.
- Aluminum body, spout, and internal parts are nickel plated to prevent contamination and corrosion.
- Seals provide maximum durability and chemical resistance to higher concentrations of ethanol.
- Strong flow (up to 100 gpm / 378.5 Lpm)
- Comes standard with a full grip guard

New Nozzles with NPT Inlet

MODEL NO.	DESCRIPTION	SHIPPING WEIGHT LBS (KG)
875010N [^]	with Two Position Hold Open Device	3.9 (1.7)
		[^] NOT LISTED

New Nozzles wit BSP Threads

MODEL NO.	DESCRIPTION	SHIPPING WEIGHT LBS (KG)
875038N [^]	with Two Position Hold Open Device	3.9 (1.7)
		[^] NOT LISTED



MODEL NO.
875010N[^]



 WARNING: Cancer and Reproductive Harm - www.P65Warnings.ca.gov

1690 WN Nozzles

Extreme High-Flow automatic shut-off nozzle for distilled spirits dispensing.

Dimensions

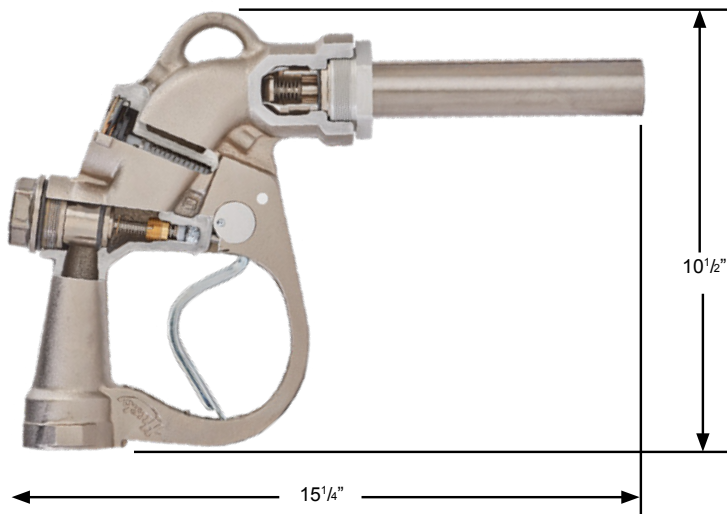

Construction

Body	Nickel-plated sand cast aluminum
Seals	Fluorocarbon
Packing	Double o-ring seal protected by fiber-reinforced Teflon®
Lever	One piece contoured steel
Inlet	1-1/2" (38.1 mm) NPT or 1-1/2" (38.1 mm) BSP

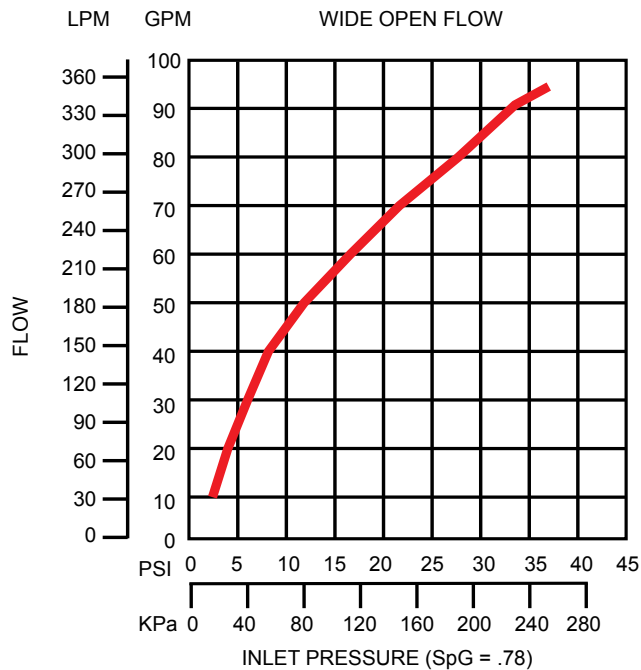

1690 WN **Nozzles**

Extreme High-Flow automatic shut-off nozzle for distilled spirits dispensing.

Nozzle Options

Hold Open Latch Pin Options

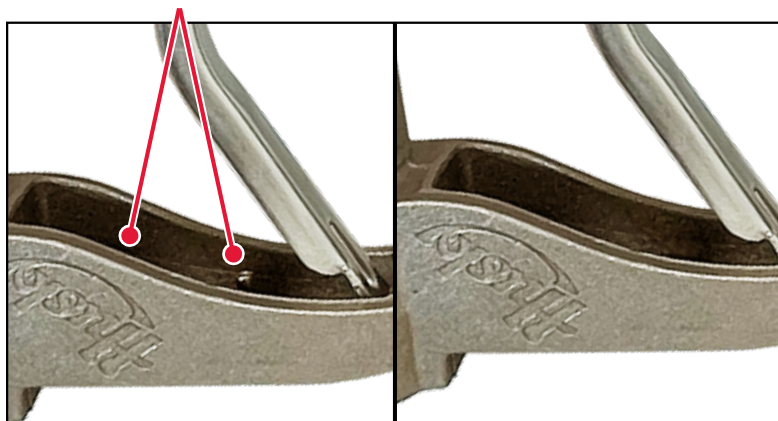

With Hold Open Latch Pins

Without Hold Open Latch Pins



GENERAL FUELING PRODUCTS

Swivels

Standard Swivels

For standard fueling applications.

Features

All Husky® Multi-Plane Swivels

- Compatible with unleaded, diesel, and Ethanol blends through E10
- Compact and light weight for easy handling
- High flow rates due to laminar flow design
- High strength step shoulder bearing diameters and impact absorbing stops

Model 002950 Restricted Swivel

- Multi-Plane, 210° spherical rotation at the swivel nut
- Double o-ring seals at each swivel provide long life at low temperatures (-40° F/C).

All Weather Swivels

- Multi-Plane, full 360° spherical rotation for easy movement of nozzle
- Double o-ring seals at each swivel provide long life at low temperatures (-40° F/C).

Model No.	Size	Thread	Type	Shipping Wt Lbs/Kg
000350	3/4" M x 3/4" F	NPT	Multi-Plane Swivel	.50/.22
000352	1" M x 3/4" F	NPT	Multi-Plane Swivel	.66/.29
000355	3/4" M x 3/4" F	NPT	Multi-Plane Swivel, Black	.49/.22
000356	1" M x 3/4" F	NPT	Multi-Plane Swivel, Black	.66/.29
002272	3/4" M x 3/4" F	NPT	90° Swivel	.38/.17
001491	3/4" M x 3/4" F	BSPT	Multi-Plane Swivel	.50/.22
003590	3/4" M x 3/4" F	BSPP	Multi-Plane Swivel	.60/.27
003590A*	3/4" M x 3/4" F	BSPP	Multi-Plane Swivel - Atex	.60/.27
002771	3/4" M x 3/4" F	BSPP	90° Swivel	.38/.17
002771A*	3/4" M x 3/4" F	BSPP	90° Swivel - Atex	.38/.17

Construction

Body: High Aluminum Zinc Alloy

Inner O-ring: Fluorsilicone

Outer O-ring: Fluorocarbon

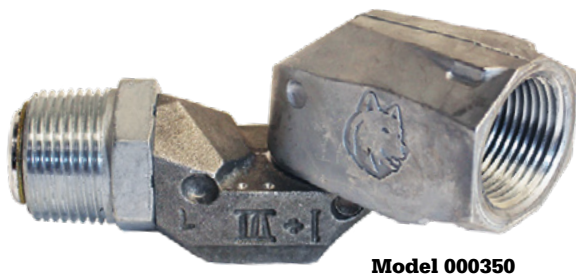

WARNING: Cancer and Reproductive Harm - www.P65Warnings.ca.gov

Standard Swivels

For standard fueling applications.

Dimensions

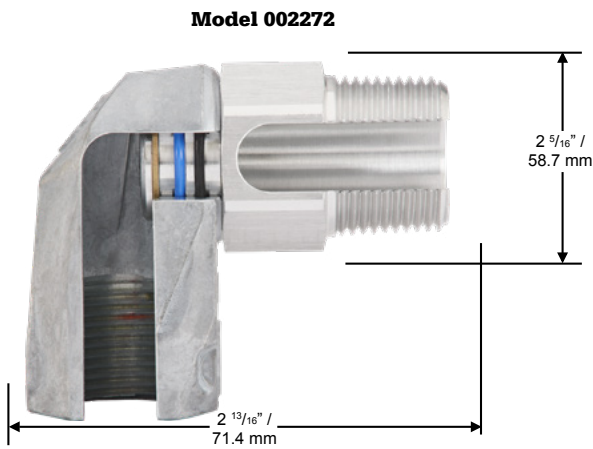
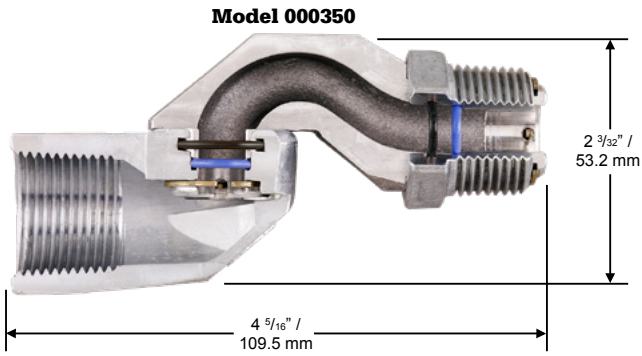

Flow Charts

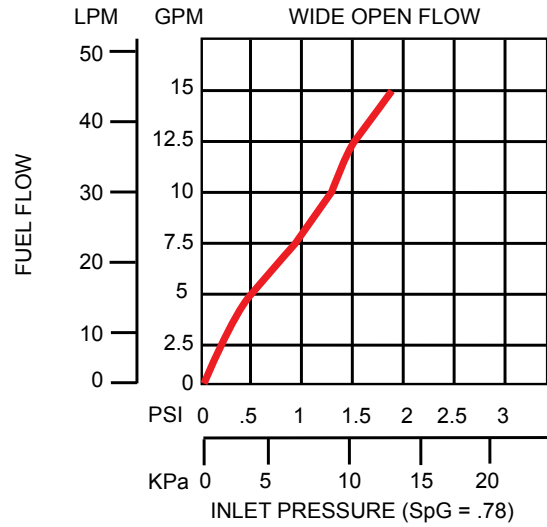

Inline Swivels

For standard fueling applications.

Features

All Husky® Multi-Plane Swivels

- Compatible with unleaded, diesel, and Ethanol blends through E10
- Compact and light weight for easy handling
- High flow rates due to laminar flow design
- High strength step shoulder bearing diameters and impact absorbing stops

All Weather Swivels

- Multi-Plane, full 360° spherical rotation for easy movement of nozzle
- Double o-ring seals at each swivel provide long life at low temperatures (-40° F/C).

Model No.	Size	Thread	Type	Shipping Wt Lbs/Kg
003895	3/4" M x 3/4" F	NPT	Single Plane Swivel	1.4/.65
003898	3/4" M x 1" F	NPT	Single Plane Swivel	1.4/.65
008517	1" M x 1" F	NPT	Single Plane Swivel	1.4/.65
003753	3/4" M x 3/4" F	BSPT	Single Plane Swivel	1.4/.65
003760	3/4" M x 1" F	BSPT	Single Plane Swivel	1.4/.65
003830	1" M x 1" F	BSPP	Single Plane Swivel	1.4/.65

Construction

Body: Aluminum
 Inner O-ring: Fluorsilicone
 Outer O-ring: Fluorosilicone

Model 003895



WARNING: Cancer and Reproductive Harm - www.P65Warnings.ca.gov

Inline Swivels

For standard fueling applications.

Dimensions

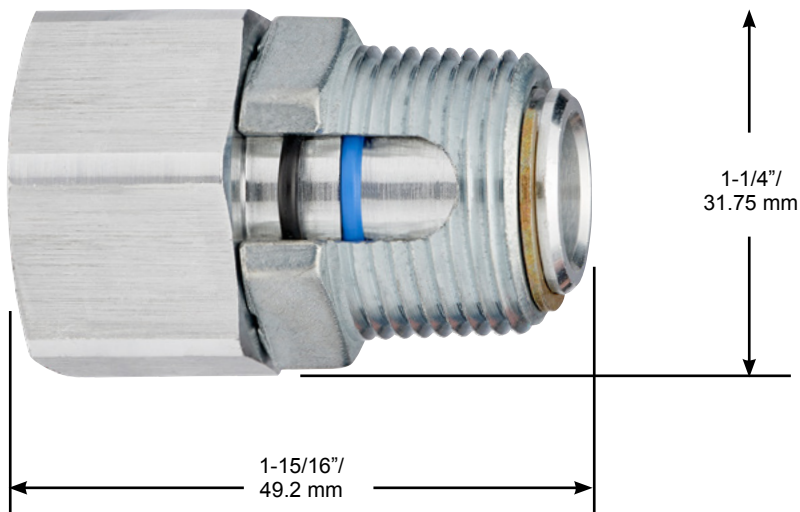

F&C Standard Swivels

For standard fueling applications.

Features

All Husky® Multi-Plane Swivels

- Compatible with unleaded, diesel, and Ethanol blends through E10
- Compact and light weight for easy handling
- High flow rates due to laminar flow design
- High strength step shoulder bearing diameters and impact absorbing stops

Model 002950 Restricted Swivel

- Multi-Plane, 210° spherical rotation at the swivel nut
- Double o-ring seals at each swivel provide long life at low temperatures (-40° F/C).

All Weather Swivels

- Multi-Plane, full 360° spherical rotation for easy movement of nozzle
- Double o-ring seals at each swivel provide long life at low temperatures (-40° F/C).

Model No.	Size	Thread	Type	Shipping Wt Lbs/Kg
000350	3/4" M x 3/4" F	NPT	Multi-Plane Swivel	.50/.22
000350R	3/4" M x 3/4" F	NPT	Multi-Plane Swivel for Retail	.50/.22
000352	1" M x 3/4" F	NPT	Multi-Plane Swivel	.66/.29
000355	3/4" M x 3/4" F	NPT	Multi-Plane Swivel, Black	.49/.22
000356	1" M x 3/4" F	NPT	Multi-Plane Swivel, Black	.66/.29
002272	3/4" M x 3/4" F	NPT	90° Swivel	.38/.17
001491	3/4" M x 3/4" F	BSPT	Multi-Plane Swivel	.50/.22
003590	3/4" M x 3/4" F	BSPP	Multi-Plane Swivel	.60/.27
003590A*	3/4" M x 3/4" F	BSPP	Multi-Plane Swivel - Atex	.60/.27
002771	3/4" M x 3/4" F	BSPP	90° Swivel	.38/.17
002771A*	3/4" M x 3/4" F	BSPP	90° Swivel - Atex	.38/.17

Construction

Body: High Aluminum Zinc Alloy
 Inner O-ring: Fluorsilicone
 Outer O-ring: Fluorocarbon

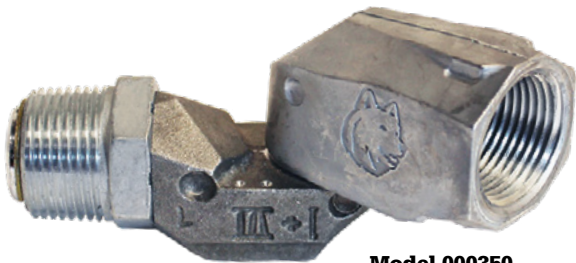

Model 000350



Model 002272



WARNING: Cancer and Reproductive Harm - www.P65Warnings.ca.gov

F&C Standard Swivels

For standard fueling applications.

Dimensions

Model 000350

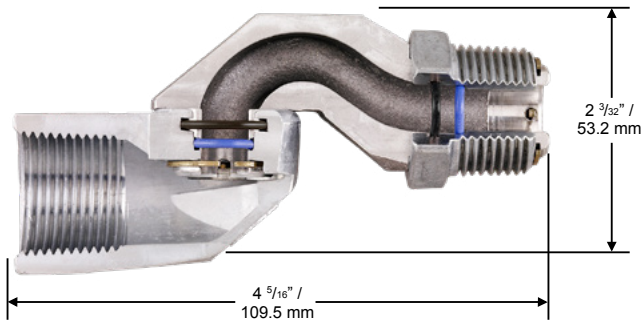

Model 002272

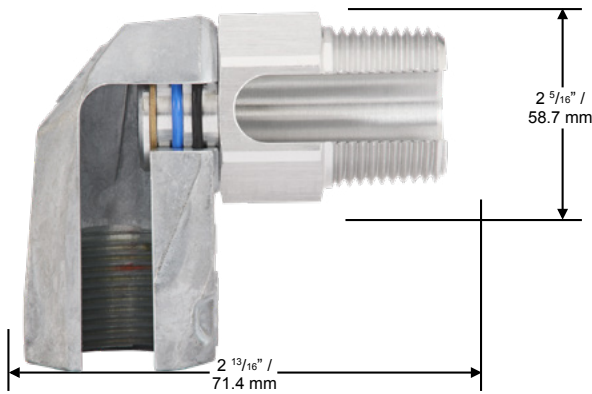

Flow Charts

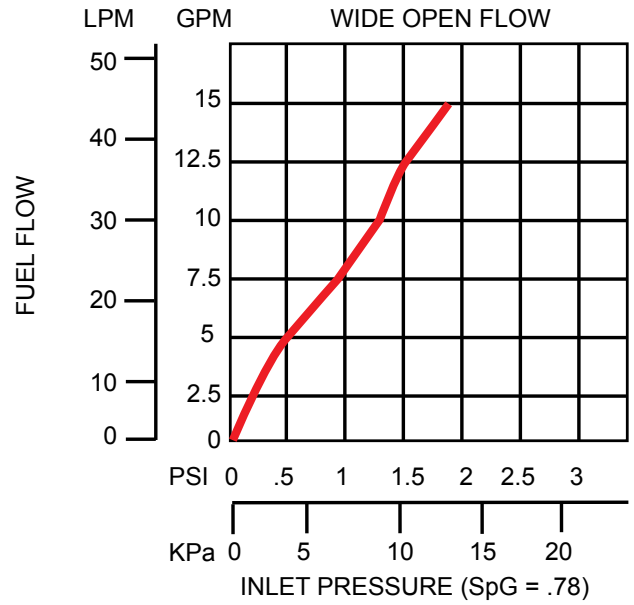

F&C High Volume Swivels

For standard fueling applications.

Features

All Husky® Multi-Plane Swivels

- Compatible with diesel fuels and Ethanol blends through E10
- Compact and light weight for easy handling
- High flow rates due to laminar flow design
- High strength step shoulder bearing diameters and impact absorbing stops
- Double o-ring seals at each swivel provide long life at low temperatures (-40° F/C).

Husky® High Volume Multi-Plane Swivels

- Multi-Plane, full 360° spherical rotation for easy movement of nozzle
- For use with high flow nozzles with flow rates up to 100 gpm/ 378 Lpm
- Raised stainless steel ball bearings provide easy joint movement, greatly improving ease of swivel when used on higher pressure systems.
- 75% less back pressure

Husky® Multi-Plane Restricted Swivels

- Multi-Plane, 210° spherical rotation at the swivel nut

Model No.	Size	Thread	Type	Shipping Wt Lbs/Kg
000087	1" M x 1" F	NPT	Multi-Plane Swivel	.96/.43
000087R	1" M x 1" F	NPT	Multi-Plane Swivel For Retail	.96/.43
004860	1" M x 1" F	NPT	High Flow Multi-Plane Swivel	1.4/.63
004860R	1" M x 1" F	NPT	High Flow Multi-Plane Swivel For Retail	1.4/.63
000095	1" M x 1" F	NPT	70° Pump Swivel	.76/.34
003395	1" M x 1" F	NPT	Restricted Multi-Plane Swivel	.93/.42
003306	1" M x 1" F	BSPP	Multi-Plane Swivel	1.1/.49
003306A*	1" M x 1" F	BSPP	Multi-Plane Swivel – Atex	1.1/.49
006949	1" M x 1" F	BSPP	High Flow Multi-Plane Swivel	1.1/.49
006949A*	1" M x 1" F	BSPP	High Flow Multi-Plane Swivel – Atex	1.1/.49

Construction

Standard

Body: High Aluminum Zinc Alloy
 Inner O-ring: Fluorsilicone
 Outer O-ring: Fluorocarbon

High Volume

Body: Aluminum, Zinc and Zinc-Plated Steel
 Inner O-ring: Fluorsilicone
 Outer O-ring: Fluorocarbon

Model 000087



Model 000095



Model 004860



WARNING: Cancer and Reproductive Harm - www.P65Warnings.ca.gov

F&C High Volume Swivels

For standard fueling applications.

Dimensions

Model 000087, 003306, and 003395

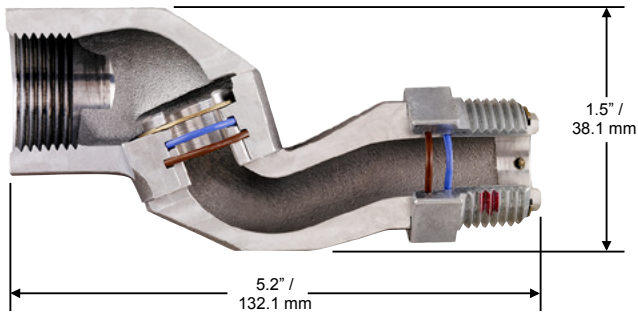

Model 004860 and 006949

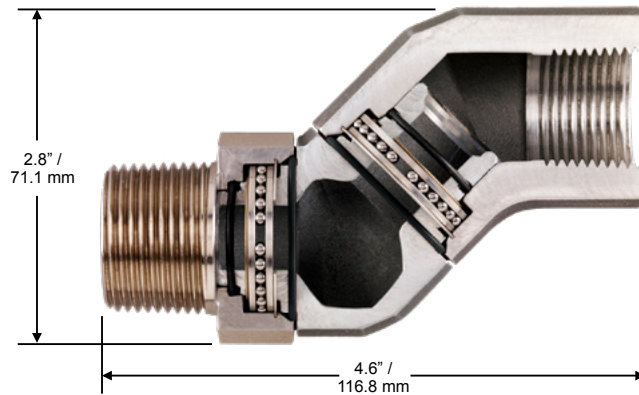

Model 000095

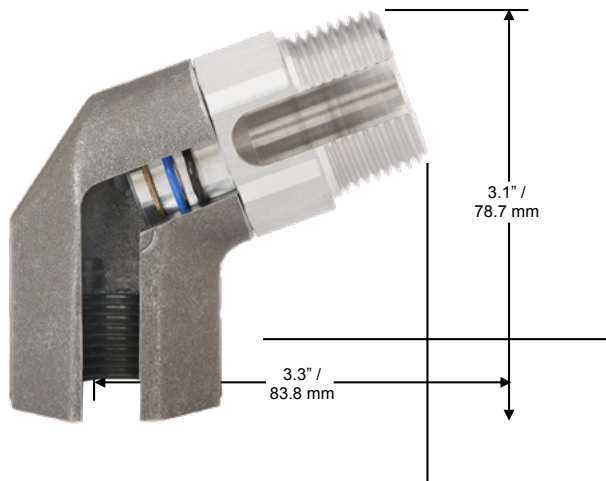

Flow Chart

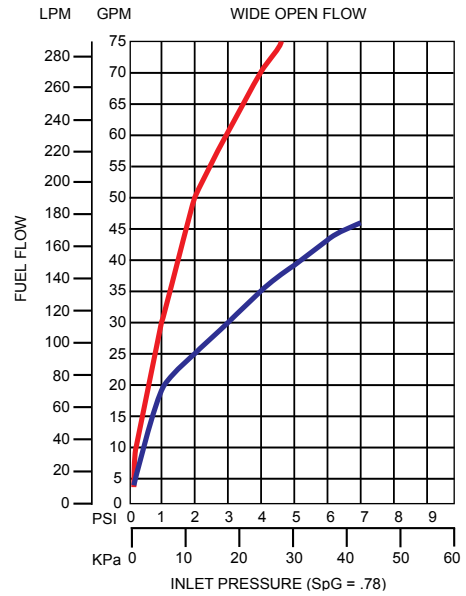

— Model 004860
 — Models 000087, 000095

Vapor Recovery Swivels

Vapor Recovery Swivel is compatible with most vacuum assist vapor recovery systems.

Features

- EVR Certified per CAB CP-201
- 360° rotation at each swivel joint
- Double o-rings at each swivel joint
- Can be installed at the nozzle or at the dispenser
- Stainless steel ball bearings and races allow for easy joint movement and reduces friction, thus extending the life of the swivel.
- Has 2 (two) plane rotation
- Exceptional flow rate and reduced back pressure
- Lightweight and compact

Model No.	Size	Thread	Type	Shipping Wt Lbs/Kg
004605	M34 x 1.5"	M34	Multi-Plane Swivel	1.0 (.45)
004605A*	M34 x 1.5"	M34	Multi-Plane Swivel - Atex	1.0 (.45)
014620	1-1/4"	1-1/4" x 18	Multi-Plane Swivel, 1-1/4"	1.0 (.45)

Construction

Body: Zinc
Inlet Body: Aluminum
Swivel Nut: Electroless, Nickel Plated Aluminum or Steel
Seals: Fluorocarbon

Model VR Swivel



WARNING: Cancer and Reproductive Harm - www.P65Warnings.ca.gov

Vapor Recovery Swivels

Vapor Recovery Swivel is compatible with most vacuum assist vapor recovery systems.

Dimensions

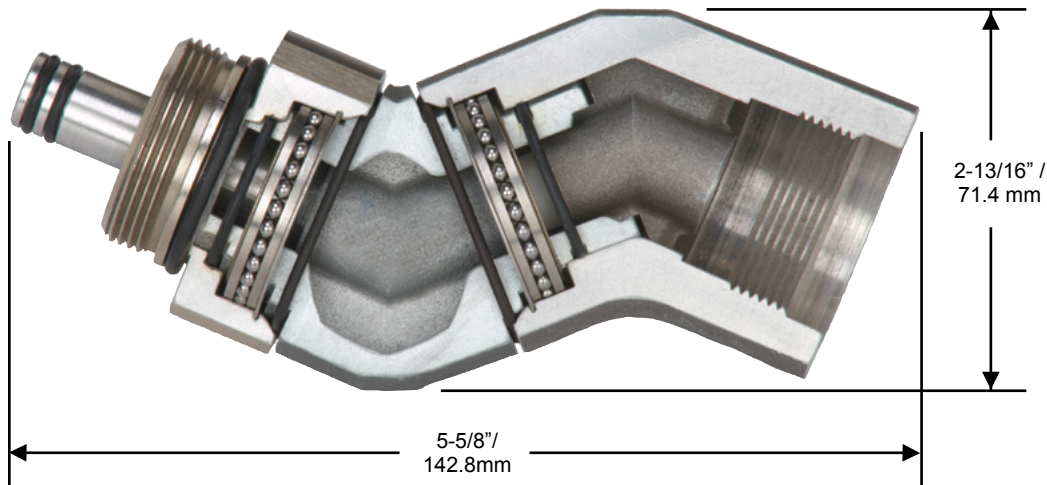

Flow Chart

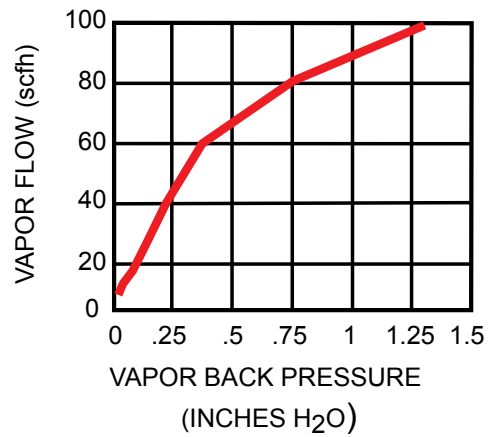
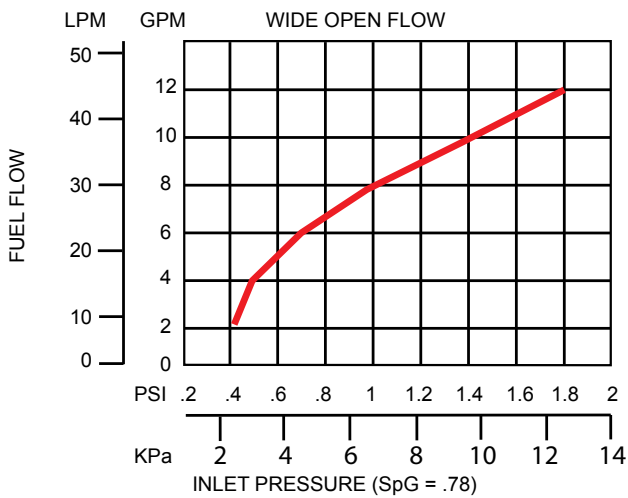

High Volume Swivels

For truck and high volume fueling.

Features

All Husky® Multi-Plane Swivels

- Compatible with diesel fuels and Ethanol blends through E10
- Compact and light weight for easy handling
- High flow rates due to laminar flow design
- High strength step shoulder bearing diameters and impact absorbing stops
- Double o-ring seals at each swivel provide long life at low temperatures (-40° F/C).

Husky® High Volume Multi-Plane Swivels

- Multi-Plane, full 360° spherical rotation for easy movement of nozzle
- For use with high flow nozzles with flow rates up to 100 gpm/378 Lpm
- Raised stainless steel ball bearings provide easy joint movement, greatly improving ease of swivel when used on higher pressure systems.
- 75% less back pressure

Husky® Multi-Plane Restricted Swivels

- Multi-Plane, 210° spherical rotation at the swivel nut

Model 004860



Model 000087



Model No.	Size	Thread	Type	Shipping Wt Lbs/Kg
000087	1" M x 1" F	NPT	Multi-Plane Swivel	.96/.43
004860	1" M x 1" F	NPT	High Flow Multi-Plane Swivel	1.4/.63
000095	1" M x 1" F	NPT	70° Pump Multi-Plane Swivel	.76/.34
003395	1" M x 1" F	NPT	90° Swivel	.93/.42
003306	1" M x 1" F	BSPP	Multi-Plane Swivel	1.1/.49
003306A*	1" M x 1" F	BSPP	Multi-Plane Swivel – Atex	1.1/.49
006949	1" M x 1" F	BSPP	High Flow Multi-Plane Swivel	1.1/.49
006949A*	1" M x 1" F	BSPP	High Flow Multi-Plane Swivel – Atex	1.1/.49

Construction

Standard

Body: High Aluminum Zinc Alloy
 Inner O-ring: Fluorsilicone
 Outer O-ring: Fluorocarbon

High Volume

Body: Aluminum, Zinc and Zinc-Plated Steel
 Inner O-ring: Fluorsilicone
 Outer O-ring: Fluorocarbon

Model 000095



WARNING: Cancer and Reproductive Harm - www.P65Warnings.ca.gov

High Volume Swivels

For truck and high volume fueling.

Dimensions

Model 000087, 003306, and 003395

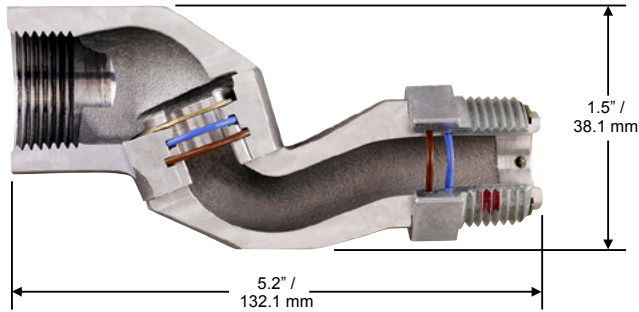

Model 004860 and 006949

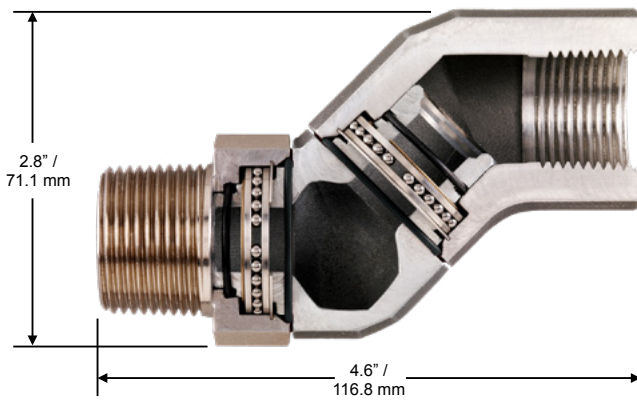

Model 000095

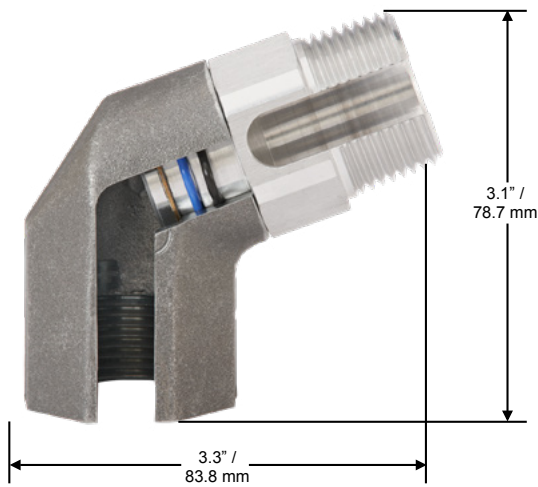

Flow Chart

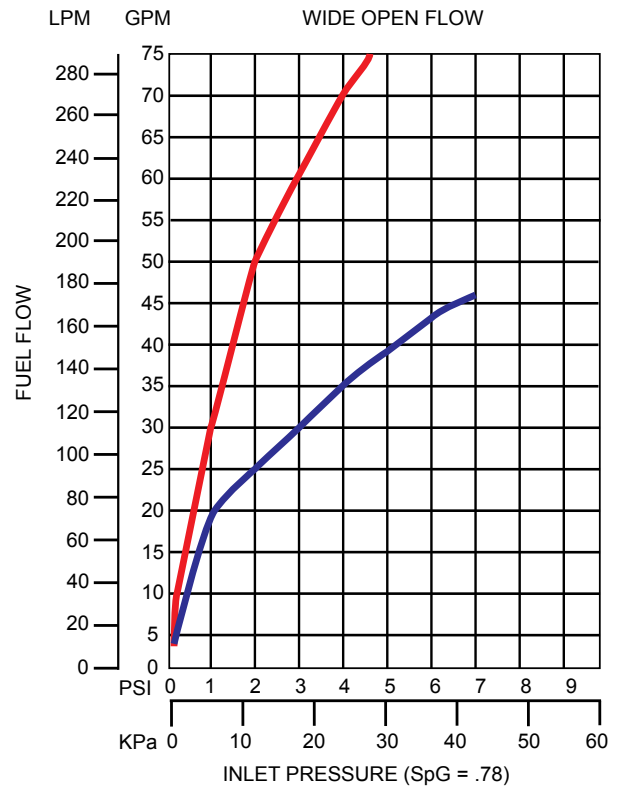

— Model 004860, 006949
 — Models 000087, 000095

Ultra High Flow Swivels

Husky® high volume delivery swivels make it easier to manipulate the long, heavy hoses used on bulk delivery systems.

Features

- Prevents kinking and twisting of hose
- Unique stainless steel ball bearing design provides easier joint movement during high pressure applications.
- Easier to angle the nozzle into fill openings

Model 005265



Model No.	Size	Thread	Type	Shipping Wt Lbs/Kg
005235	1¼" F x 1¼" M	NPT	Single Plane Swivel	1.4/.65
005240	1¼" F x 1½" M	NPT	Single Plane Swivel	1.4/.65
005265	1½" F x 1¼" M	NPT	Single Plane Swivel	1.4/.65
005266	1½" F x 1½" M	NPT	Single Plane Swivel	1.4/.65
005754	1¼" F x 1½" M	BSPP	Single Plane Swivel	1.4/.65

Construction

Body: Aluminum
Seals: Fluorocarbon



⚠ WARNING: Cancer and Reproductive Harm - www.P65Warnings.ca.gov

Ultra High Flow Swivels

Husky® high volume delivery swivels make it easier to manipulate the long, heavy hoses used on bulk delivery systems.

Dimensions

Model 005235, 005240, 005265 and 005266

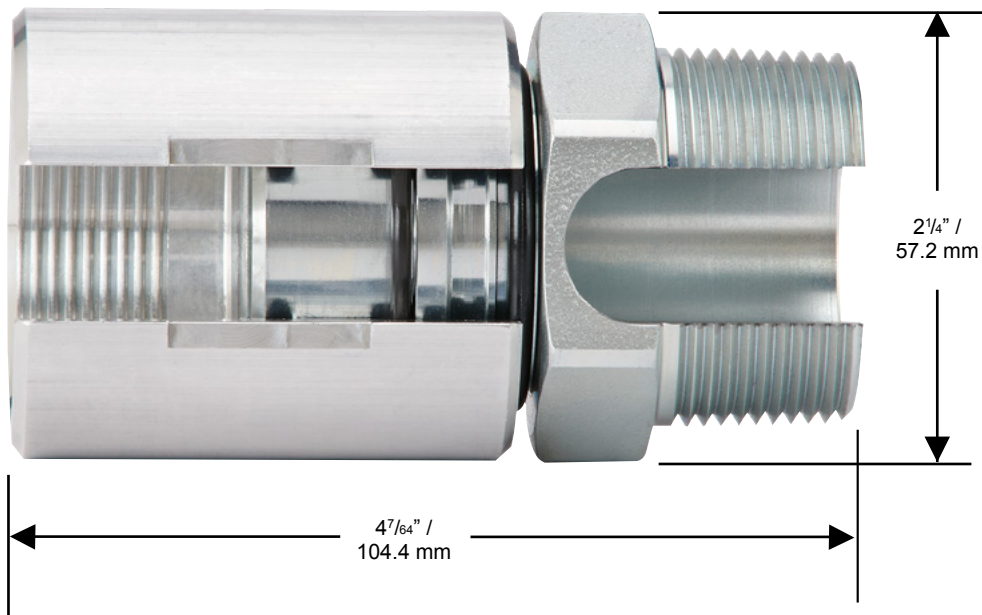

DEF Swivels

Diesel Exhaust Fluid Inline Swivels.

Features

- Full 360° rotation for easy movement of nozzle
- Relieves kinking and twisting of the hose
- High flow rate featuring laminar flow design
- Compact for easy handling
- Unique to Husky® products, the steel ball bearing design provides easier joint movement during high pressure applications.
- DEF compatible thread sealant required for NPT threads only

Construction

Body: Stainless Steel, Anodized Aluminum
 Seals: Fluorocarbon
 Nut: Stainless Steel

Model No.	Size	Thread	Type	Shipping Wt Lbs/Kg
007269	1" M x 1" M	BSPP	Inline Swivel	.60/.27
007275	1" M x M34 M	BSPP/M34	Inline Swivel	.62/.28
007282	3/4" M x 3/4" Hose Barb	BSPP	Roller Bearing Inline Swivel	.42/.19
007467	1" F x 1" M	BSPP	Inline Swivel	.66/.30
008510	1" M x 1" F	BSPP/NPT	Inline Swivel	.66/.30
008822	1" F x 1" M	BSPP	Face Seal Inline Swivel	.66/.30
010936	3/4" M x 3/4" Hose Barb	BSPP	Inline Swivel	.42/.19
012604^	3/4" M x 3/4" F	NPT	Roller Bearing Inline Swivel	.23/.10
012656^	3/4" M x 3/4" F	BSPP	Roller Bearing Inline Swivel	.23/.10

^ NOT LISTED

Accessories

Model No.	Description
007406	3/4" BSPP Seal Kit Assembly
007407	1" BSPP Seal Kit Assembly

Model 007269



Model 007275



Model 012604/012656



Model 007467/008510/008822



Model 007282/010936



^ NOT LISTED

WARNING: Cancer and Reproductive Harm - www.P65Warnings.ca.gov

DEF Swivels

Diesel Exhaust Fluid Inline Swivels.

Dimensions

Model 007269

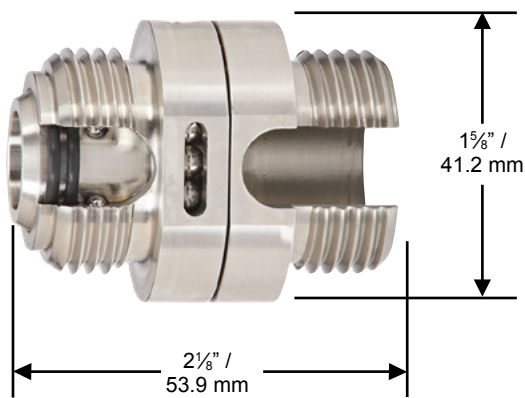

Model 007282/010936

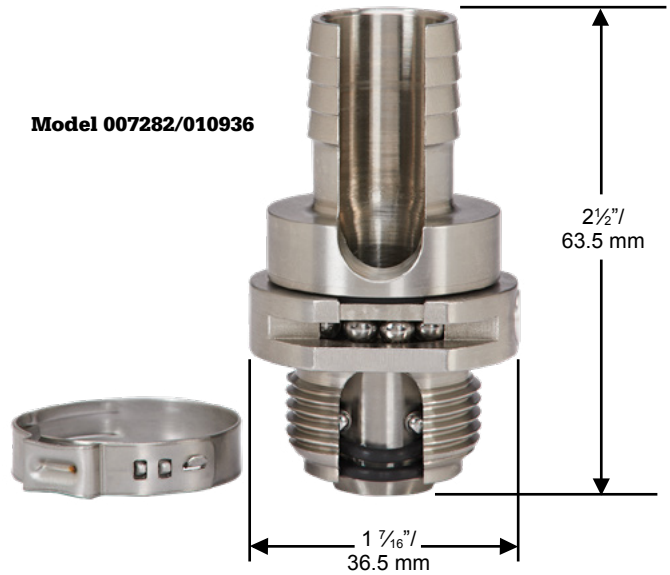

Model 007467/008510/008822

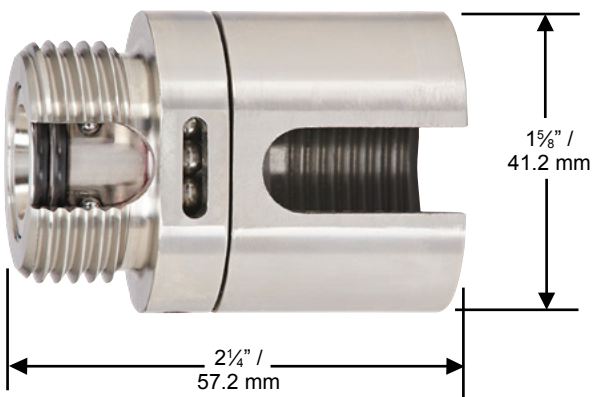

Model 007275

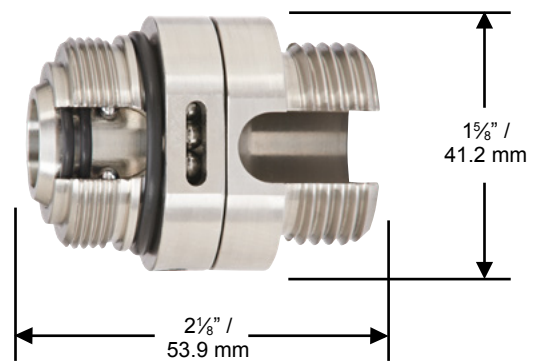

E85 Swivel

Husky Model 6350 Multi-Plane Swivel.

Features

- Multi-Plane, Full 360° spherical rotation for easy movement of nozzle
- Compatible with unleaded, diesel, and all Ethanol blends through E100
- Compatible with fuels containing alcohol
- High flow rate due to laminar flow design
- Compact and light weight for easy handling
- Double o-ring seals at each swivel provide long life and low temperature (-40° F/C) performance.
- High strength step shoulder bearing diameters and impact absorbing stops

Model No.	Size	Thread	Type	Shipping Wt Lbs/Kg
6350	3/4" M x 3/4"	NPTF	Multi-Plane Swivel	.44/.19

Construction

Body: Aluminum with Electroless Nickel Plating

Inner O-ring: Fluorosilicone

Outer O-ring: Fluorocarbon

Model 6350



E85 Swivel

Husky Model 6350 Multi-Plane Swivel.

Dimensions

Model 6350

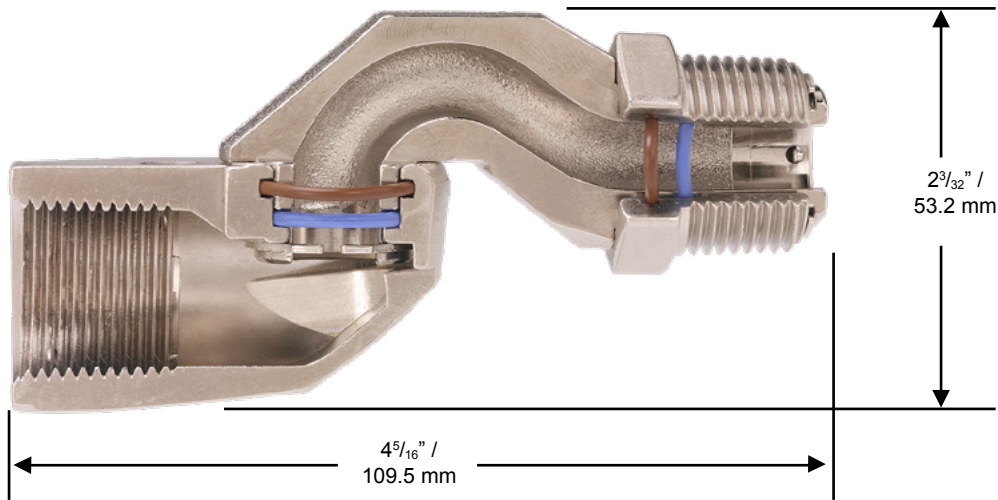

Flow Chart

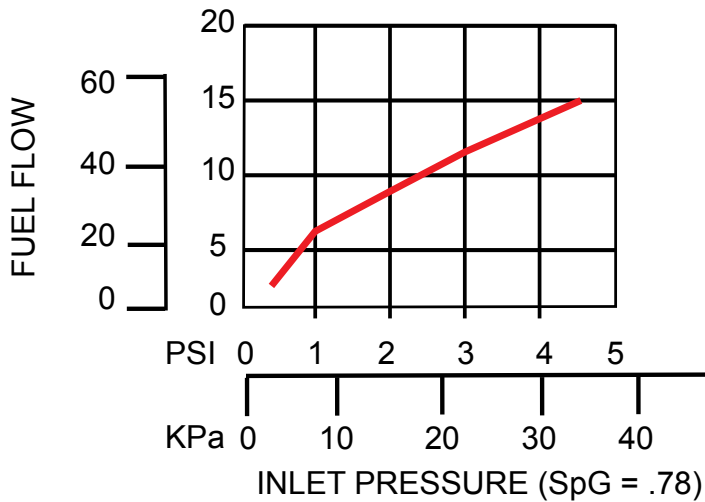



GENERAL FUELING PRODUCTS

Safe-T-Breaks®

Standard **STB**

All Husky® Safe-T-Breaks® stop the flow of fuel on both sides of the separation and have passed the demanding UL test requirements on separations without leaking or failing.

Models 003360 & 003385

- Retains UL listing after reconnection
- Features a pre-loaded spring and a single turn wave spring that enables valve to resist sudden pressure build-up in the hose causing nuisance separations
- Separates using ball bearings and latch ring at less than 200 lbf / 889.6 N which minimizes “backlash” force of separation, reducing damage to equipment

Model 005230

- Retains UL listing after reconnection
- Uses the same pre-loaded spring and a single turn wave spring as Model 003360
- Separates using ball bearings and latch ring at less than 115 lbf / 511.5 N

Model 002273 & 002774

- Light-weight, inexpensive and disposable
- Same instant-closing dual poppet check valve design as Model 003360
- Separates using shear pins at less than 300 lbf / 1334.4 N

Model 006130

- Internal Pressure Compensating Chamber (PCC) that prevents “line shock” nuisance separations
- Same instant-closing dual poppet check valve as Model 003360
- Separates using shear pins at less than 225 lbf / 1000.8 N

Models 015130 & 015349

- Internal Pressure Compensating Chamber (PCC) that prevents “line shock” nuisance separations
- Same instant-closing dual poppet check valve as Model 002276
- Features a pre-loaded spring and a single turn wave spring that enables valve to resist fatigue from repeated hose stretching
- Separates using ball bearings and latch ring at less than 250 lbf / 1,112.1 N

Model 002273



Model 003360



Model 006130



Reconnectable with NPT

MODEL NO.	DESCRIPTION	SHIPPING WEIGHT LBS (KG)
003360**	¾" F x ¾" F Reconnectable Safe-T-Break® with scuff guard	0.59 (0.26)
005230**	¾" F x ¾" F Reconnectable Low-Pull Safe-T-Break® with scuff guard	0.59 (0.26)

Non-reconnectable with NPT

MODEL NO.	DESCRIPTION	SHIPPING WEIGHT LBS (KG)
002273	¾" F x ¾" F Non-Reconnectable Safe-T-Break®	0.78 (0.35)
006130**	¾" F x ¾" F PCC Non-Reconnectable Safe-T-Break® with scuff guard	0.52 (0.23)
015130**	¾" F x ¾" F LH PCC Non-Reconnectable Safe-T-Break® with scuff guard	0.52 (0.23)

Reconnectable with BSPP

MODEL NO.	DESCRIPTION	SHIPPING WEIGHT LBS (KG)
003385**	¾" F x ¾" F Reconnectable Safe-T-Break® with scuff guard	0.57 (0.25)

Non-reconnectable with BSPP

MODEL NO.	DESCRIPTION	SHIPPING WEIGHT LBS (KG)
002274	¾" F x ¾" F Non-Reconnectable Safe-T-Break®	0.73 (0.33)
002774A*	¾" F x ¾" F Non-Reconnectable Safe-T-Break® - Atex	0.73 (0.33)
015349**	¾" F x ¾" F LH PCC Non-Reconnectable Safe-T-Break®	0.52 (0.23)

**See page 2 for guard color options

Construction

RECONNECTABLE SAFE-T-BREAKS®

Body	Aluminum
Seals	Fluorocarbon
Springs	Stainless Steel
	Stainless steel load and latch spring reverse mechanism
	Hardened stainless steel latch ring and balls

NON-RECONNECTABLE SAFE-T-BREAKS®

Body	Zinc Alloys and Aluminum
------	--------------------------

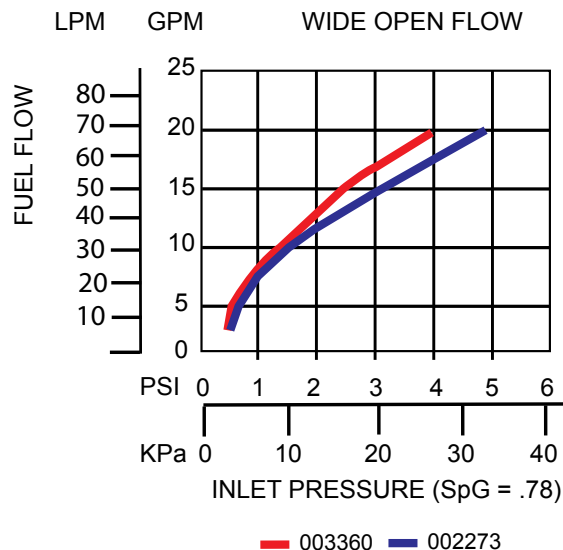

0518
II 1 G
EN 13617-2

⚠ WARNING: Cancer and Reproductive Harm - www.P65Warnings.ca.gov

Standard STB

All Husky® Safe-T-Breaks® stop the flow of fuel on both sides of the separation and have passed the demanding UL test requirements on separations without leaking or failing.

Dimensions and System Options

Guards

MODEL NO.	DESCRIPTION
003096**	Scuff Guard for Model #003360, 006130 and 005230
006503**	Dispenser Scuff Guard for Model #002273 and 002774
003098	Scuff Guard for Model #015130 & 015349

Accessories, Testing and Maintenance

MODEL NO.	DESCRIPTION
007000	Safe-T-Break® Drain Cup
003813	Safe-T-Break® Demonstration Kit

Guard Color Chart

COLOR	SUFFIX	COLOR	SUFFIX	COLOR <i>CUSTOM</i>	SUFFIX
Blue	-01	Gold	-08	Amoco Blue	-07 <i>CUSTOM</i>
Red	-02	Silver	-09	Apple Green	-18 <i>CUSTOM</i>
Green	-03	BP Green	-16	Purple	-19 <i>CUSTOM</i>
Black	-04	M Blue	-25	Pink	-20 <i>CUSTOM</i>
Yellow	-05	Orange	-39	BPS Green	-22 <i>CUSTOM</i>
White	-06				

Scuff Guards are to be ordered with the corresponding guard color option added to the model number. Example: If BLUE guards are desired, add guard color option -01 to the model number (159504-01). For custom colors, a minimum order of 4,000 guards will be required.

Model 003360

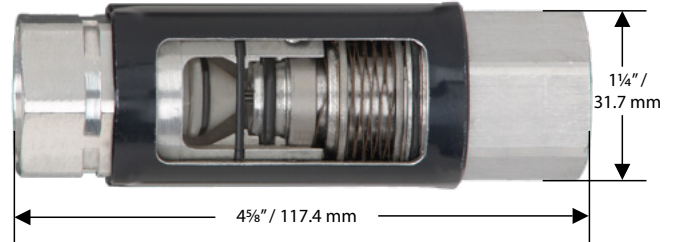

Model 006130

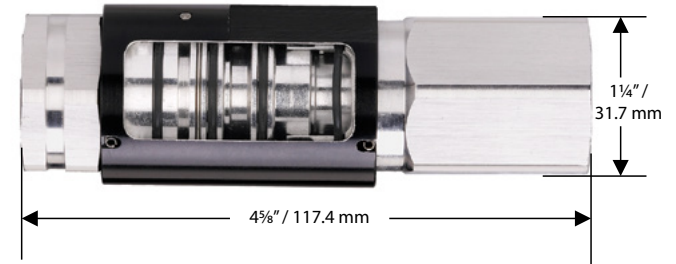

Model 002273

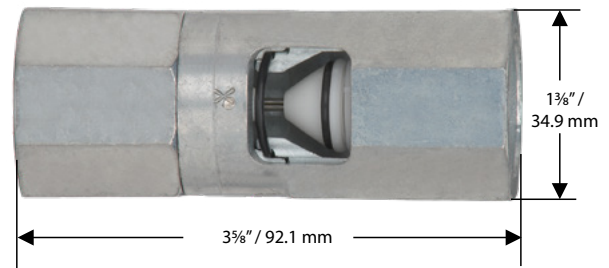

MAG MAGBREAK®

All Husky® Safe-T-Breaks® stop the flow of fuel on both sides of the separation and have passed the demanding UL test requirements on separations without leaking or failing.

G2 Magbreak®

- Low scuff, high impact resistant polymer housing
- 15% Smaller housing diameter
- Available in 3/4" Female NPT or BSP threads
- 40% Lighter than Original Magbreak®
- Separates at less than 200 pounds (889 N) pull force
- Can be separated using two flathead screwdrivers allowing for easier maintenance on hanging hardware
- Assurance of proper reconnection using a simple "Twist to Lock" feature.
- Line shock absorbing design
- Retains UL listing after reconnection

Magbreak®

- Low scuff, high impact resistant polymer housing
- Available in 3/4" or 1" female NPT or BSP threads
- Lighter than competing magnetic breakaways
- Separates at less than 225 pounds (1,000 N) pull force
- Can be separated using two flathead screwdrivers allowing for easier maintenance on hanging hardware
- Assurance of proper reconnection using a simple "Twist to Lock" feature.
- Line shock absorbing design
- Retains UL listing after reconnection

G2 Magbreak®

MODEL NO.	DESCRIPTION	SHIPPING WEIGHT LBS (KG)
008330	G2 Magbreak @ 3/4" F NPT(separates at less than 200 pounds pull force)	.72 (.32)
009910	G2 Magbreak @ 3/4" F BSP(separates at less than 200 pounds pull force)	.72 (.32)

Magbreak®

MODEL NO.	DESCRIPTION	SHIPPING WEIGHT LBS (KG)
008331	Magbreak @ 1" F NPT CK(separates at less than 225 pounds pull force)	1.09 (.50)
009911	G2 Magbreak @ 1" F BSP(separates at less than 200 pounds pull force)	1.09 (.50)
010328	Magbreak @ 3/4" F NPT CK(separates at less than 225 pounds pull force)	1.21 (.55)

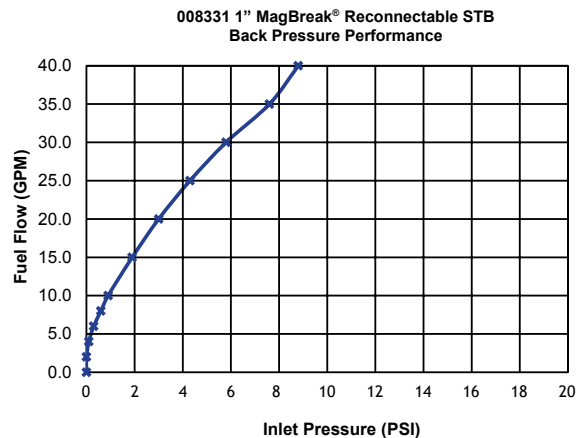
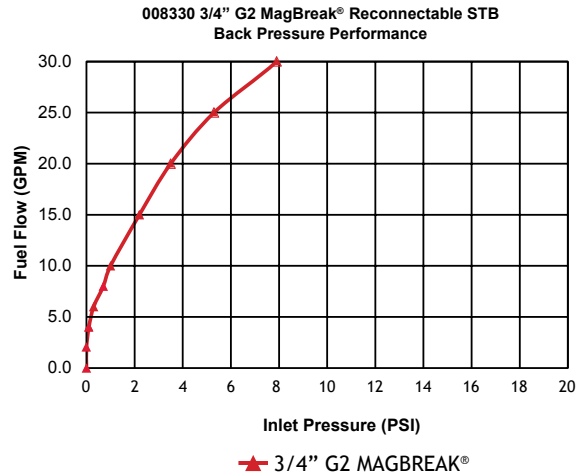

⚠ WARNING: Cancer and Reproductive Harm - www.P65Warnings.ca.gov

MAG MAGBREAK®

All Husky® Safe-T-Breaks® stop the flow of fuel on both sides of the separation and have passed the demanding UL test requirements on separations without leaking or failing.

Dimensions and System Options

Replacement Parts

MODEL NO.	DESCRIPTION
008630	MAGBREAK LOWER HALF 008330
008631	MAGBREAK LOWER HALF 008331

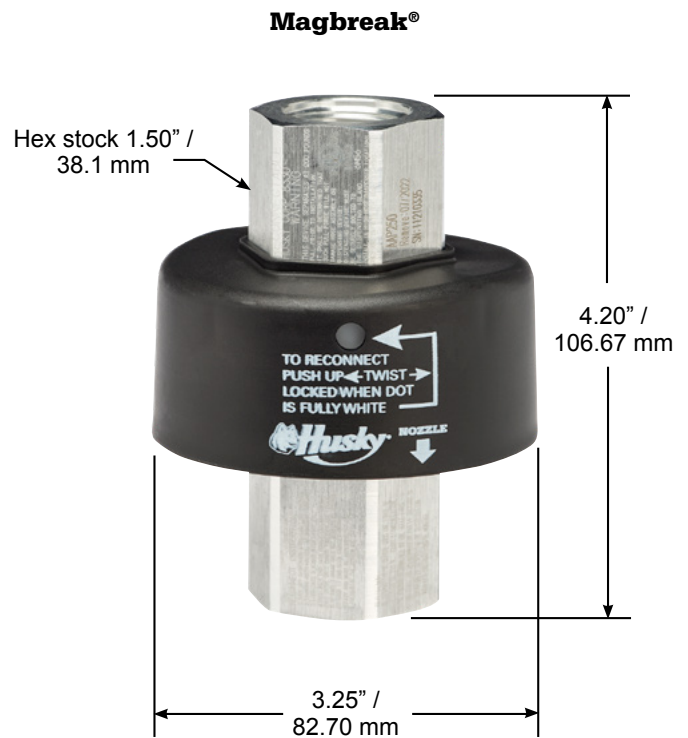

F&C Standard **STB**

All Husky® Safe-T-Breaks® stop the flow of fuel on both sides of the separation and have passed the demanding UL test requirements on separations without leaking or failing.

Models 003360 & 003385

- Retains UL listing after reconnection
- Features a pre-loaded spring and a single turn wave spring that enables valve to resist sudden pressure build-up in the hose causing nuisance separations
- Separates at less than 200 lbf/889.6 N which minimizes “backlash” force of separation, reducing damage to equipment

Model 005230

- Retains UL listing after reconnection
- Uses the same pre-loaded spring and a single turn wave spring as Model 003360
- Separates at less than 115 lbf/511.5 N

Model 002273 & 002774

- Light-weight, inexpensive and disposable
- Same instant-closing dual poppet check valve design as Model 003360
- Separates at less than 300 lbf/1334.4 N

Model 006130

- Internal Pressure Compensating Chamber (PCC) that prevents “line shock” nuisance separations
- Same instant-closing dual poppet check valve as Model 003360
- Separates at less than 225 lbf/1000.8 N

Reconnectable with NPT

MODEL NO.	DESCRIPTION	SHIPPING WEIGHT LBS (KG)
003360**	¾" F x ¾" F Reconnectable Safe-T-Break® with scuff guard	0.59 (0.26)
005230**	¾" F x ¾" F Reconnectable Low-Pull Safe-T-Break® with scuff guard	0.59 (0.26)
03360R	¾" F x ¾" F Reconnectable Safe-T-Break® With Scuff Guard For Retail	0.59 (0.26)

Non-reconnectable with NPT

MODEL NO.	DESCRIPTION	SHIPPING WEIGHT LBS (KG)
002273	¾" F x ¾" F Non-Reconnectable Safe-T-Break®	0.78 (0.35)
006130**	¾" F x ¾" F PCC Non-Reconnectable Safe-T-Break® with scuff guard	0.52 (0.23)
002273R	¾" F x ¾" F Non-Reconnectable Safe-T-Break® For Retail	0.52 (0.23)

Reconnectable with BSPP

MODEL NO.	DESCRIPTION	SHIPPING WEIGHT LBS (KG)
003385**	¾" F x ¾" F Reconnectable Safe-T-Break® with scuff guard	0.57 (0.25)

Non-reconnectable with BSPP

MODEL NO.	DESCRIPTION	SHIPPING WEIGHT LBS (KG)
002774	¾" F x ¾" F Non-Reconnectable Safe-T-Break®	0.73 (0.33)
002774A*	¾" F x ¾" F Non-Reconnectable Safe-T-Break® - Atex	0.73 (0.33)

**See page 2 for guard color options



Model 003600



Model 006130



Model 002273

Construction

RECONNECTABLE SAFE-T-BREAKS®

Body	Aluminum
Seals	Fluorocarbon
Springs	Stainless Steel Stainless steel load and latch spring reverse mechanism Hardened stainless steel latch ring and balls

NON-RECONNECTABLE SAFE-T-BREAKS®

Body	Zinc Alloys and Aluminum
------	--------------------------

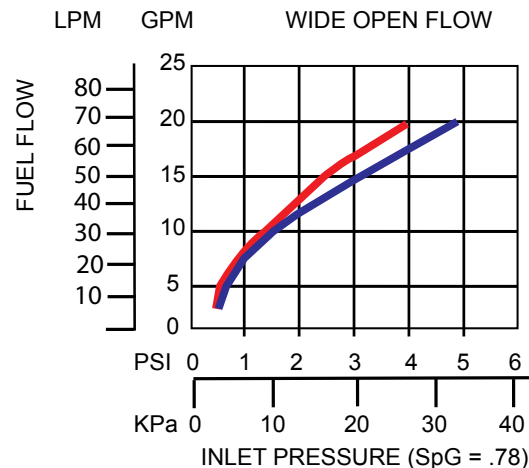

— 003360 — 002273



0518
II 1 G
EN 13617-2

⚠ WARNING: Cancer and Reproductive Harm - www.P65Warnings.ca.gov

F&C Standard STB

All Husky® Safe-T-Breaks® stop the flow of fuel on both sides of the separation and have passed the demanding UL test requirements on separations without leaking or failing.

Dimensions and System Options

Guards

MODEL NO.	DESCRIPTION
003096**	Scuff Guard for Model 003360, 006130 and 005230
006503**	Dispenser Scuff Guard for Model 002273 and 002774

Accessories, Testing and Maintenance

MODEL NO.	DESCRIPTION
007000	Safe-T-Break® Drain Cup
003813	Safe-T-Break® Demonstration Kit

Guard Color Chart

COLOR	SUFFIX	COLOR	SUFFIX	COLOR <i>CUSTOM</i>	SUFFIX
Blue	-01	Gold	-08	Amoco Blue	-07 <i>CUSTOM</i>
Red	-02	Silver	-09	Apple Green	-18 <i>CUSTOM</i>
Green	-03	BP Green	-16	Purple	-19 <i>CUSTOM</i>
Black	-04	M Blue	-21	Pink	-20 <i>CUSTOM</i>
Yellow	-05	Orange	-39	BPS Green	-22 <i>CUSTOM</i>
White	-06				

Scuff Guards are to be ordered with the corresponding guard color option added to the model number.
 Example: If BLUE guards are desired, add guard color option -01 to the model number (159504-01).
 For custom colors, a minimum order of 4,000 guards will be required.

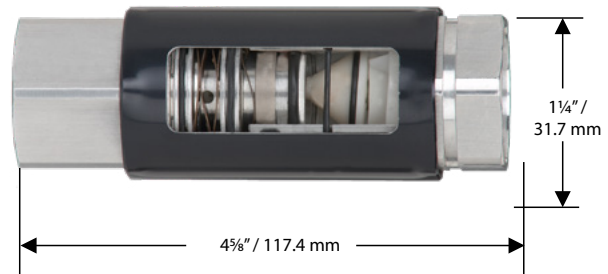
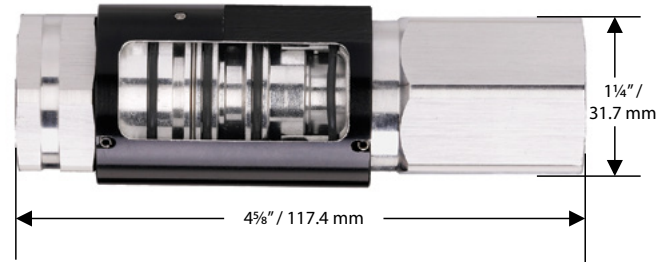
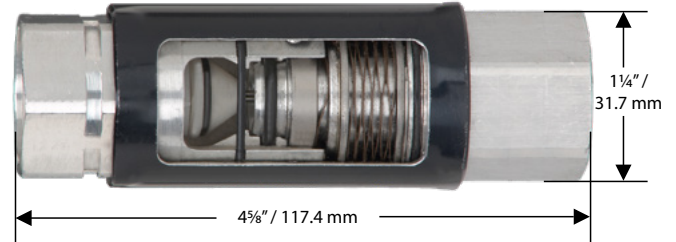

F&C High Volume **STB**

All Husky® Safe-T-Breaks® stop the flow of fuel on both sides of the separation and have passed the demanding UL test requirements on separations without leaking or failing.

Models 002276, 003076 & 003076A

- Retains UL listing after reconnection
- Internal pressure balancing chamber prevents “line shock” nuisance separations
- Separates using ball bearings and latch ring at less than 200 lbf/889.6 N which minimizes “backlash” force of separation, reducing damage to equipment

Model 005231

- Retains UL listing after reconnection
- Uses the same internal pressure balancing chamber as Model 002276
- Separates using ball bearings and latch ring at less than 115 lbf/511.5 N

Model 005812 & 006914

- Light-weight, inexpensive and disposable
- Same instant-closing dual poppet check valve design as Model 002276
- Separates using shear pins between 300 lbf/ 1334.5 N to 350 lbf/ 1556.9 N

Model 006301

- Internal Pressure Compensating Chamber (PCC) that prevents “line shock” nuisance separations
- Same instant-closing dual poppet check valve as Model 002276
- Separates using shear pins at less than 225 lbf/1000.8 N

Reconnectable with NPT

MODEL NO.	DESCRIPTION	SHIPPING WEIGHT LBS (KG)
002276	1" F x 1" F Reconnectable Safe-T-Break®	.75 (.34)
005231	1" F x 1" F Reconnectable Low-Pull Safe-T-Break®	.75 (.34)
002276R	1" F x 1" F Reconnectable Safe-T-Break®	.75 (.34)

Non-reconnectable with NPT

MODEL NO.	DESCRIPTION	SHIPPING WEIGHT LBS (KG)
005812	1" F x 1" F Non-Reconnectable Safe-T-Break®	.61 (.27)
006301	1" F x 1" F PCC Non-Reconnectable Safe-T-Break®	.69 (.31)
005812R	1" F x 1" F Non-Reconnectable Safe-T-Break®	.69 (.31)

Reconnectable with BSP

MODEL NO.	DESCRIPTION	SHIPPING WEIGHT LBS (KG)
003076	1" F x 1" F Reconnectable Safe-T-Break®	.75 (.34)
003076A*	1" F x 1" F Reconnectable Safe-T-Break® - Atex	.75 (.34)

Non-reconnectable with BSP

MODEL NO.	DESCRIPTION	SHIPPING WEIGHT LBS (KG)
006914	1" F x 1" F Non-Reconnectable Safe-T-Break®	.61 (.27)

Construction

Reconnectable Safe-T-Breaks®	
Body	Aluminum
Seals	Fluorocarbon
Springs	Stainless Steel Stainless steel load and latch spring reverse mechanism Hardened stainless steel latch ring and balls
Non-Reconnectable Safe-T-Breaks®	
Body	Aluminum

Model 002276



Model 005812

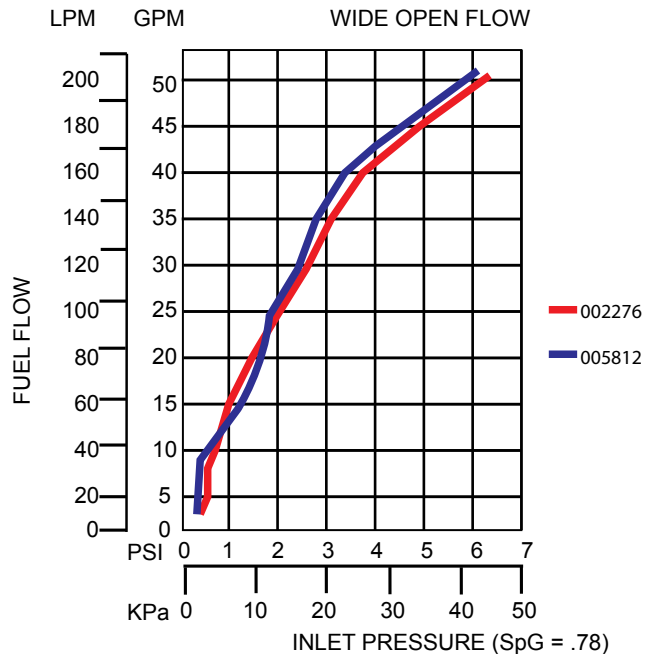

0518
II 1 G
EN 13617-2

WARNING: Cancer and Reproductive Harm - www.P65Warnings.ca.gov

F&C High Volume STB

All Husky® Safe-T-Breaks® stop the flow of fuel on both sides of the separation and have passed the demanding UL test requirements on separations without leaking or failing.

Dimensions and System Options

Guards

MODEL NO.	DESCRIPTION
003098**	Safe-T-Break® Scuff Guard

Accessories, Maintenance, and Testing

Model No.	Description
007000	Safe-T-Break® Drain Cup
003813	Safe-T-Break® Demonstration Kit

Guard Color Chart

COLOR	SUFFIX	COLOR	SUFFIX	COLOR <i>CUSTOM</i>	SUFFIX
Blue	-01	Gold	-08	Amoco Blue	-07 <i>CUSTOM</i>
Red	-02	Silver	-09	Apple Green	-18 <i>CUSTOM</i>
Green	-03	BP Green	-16	Purple	-19 <i>CUSTOM</i>
Black	-04	M Blue	-25	Pink	-20 <i>CUSTOM</i>
Yellow	-05	Orange	-39	BPS Green	-22 <i>CUSTOM</i>
White	-06				

Scuff Guards are to be ordered with the corresponding guard color option added to the model number.
 Example: If BLUE guards are desired, add guard color option -01 to the model number (159504-01).
 For custom colors, a minimum order of 4,000 guards will be required.

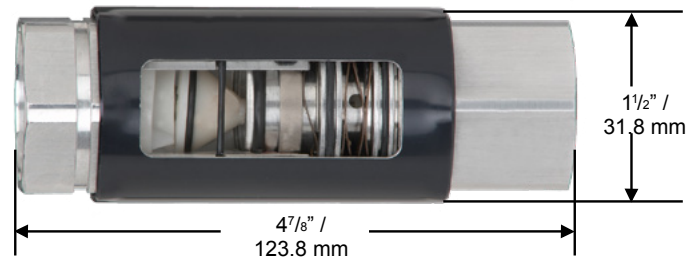
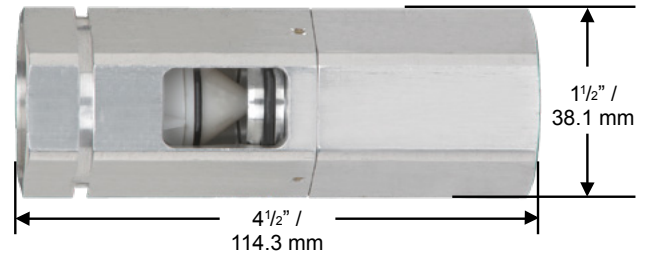

DEF Safe-T-Break®

All Husky® Safe-T-Breaks® stop the flow of fuel on both sides of the separation and have passed the demanding UL test requirements on separations without leaking or failing.

Model 007219

- Non-reconnectable Safe-T-Break®
- Low profile design
- Thread sealant not required with BSPP thread
- 100% DEF compatible parts
- Instant-closing, dual poppet check valve design
- Maximum separation of 300 lbf/1334.5 N
- Comes standard with guard

- Thread sealant not required with BSPP threads
- Instant-closing, dual poppet check valve design
- Comes standard with guard

Model 012070

- Reconnectable Safe-T-Break®
- Maximum separation of 200 lbf/889.6 N
- 100% DEF compatible parts
- Instant-closing, dual poppet check valve design

Model 008216

- Reconnectable Safe-T-Break®
- Maximum separation of 200 lbf/889.6 N
- 100% DEF compatible parts

- Comes standard with guard
- DEF compatible thread sealant required for 3/4" NPT threads

Safe-T-Breaks®

MODEL NO.	DESCRIPTION	SHIPPING WEIGHT LBS (KG)
007219	1" M x 1" M Stainless Steel Non-Reconnectable Safe-T-Break®	0.90 (.40)
008216	1" M x 1" M BSPP Stainless Steel Reconnectable Safe-T-Break®	0.94 (.43)
012070^	3/4" F x 3/4" F NPT Reconnectable Safe-T-Break®	0.54 (.20)
012659^	3/4" F x 3/4" F BSPP Reconnectable Safe-T-Break®	.54 (.20)

^ NOT LISTED

Construction

Body	Stainless Steel, 012070 - Anodized Aluminum
Seals	Fluorocarbon
Inlet	1" / 25.4 mm BSPP, 012070 - 3/4" / 19.1 mm NPT

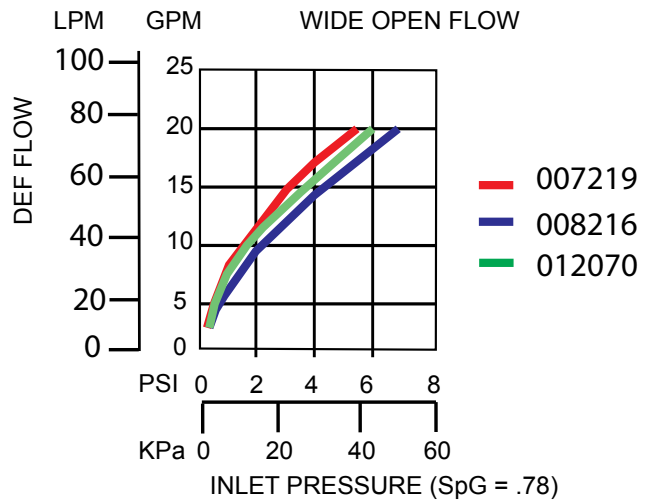

⚠ WARNING: Cancer and Reproductive Harm - www.P65Warnings.ca.gov

DEF Safe-T-Break®

All Husky® Safe-T-Breaks® stop the flow of fuel on both sides of the separation and have passed the demanding UL test requirements on separations without leaking or failing.

Dimensions and System Options

Guards

MODEL NO.	DESCRIPTION
007224	Black Scuff Guard
006534	Dispenser Scuff Guard
003097	Scuff Guard

Accessories, Testing and Maintenance

MODEL NO.	DESCRIPTION
007407	1" BSPP Seal Kit Assembly

Model 007219

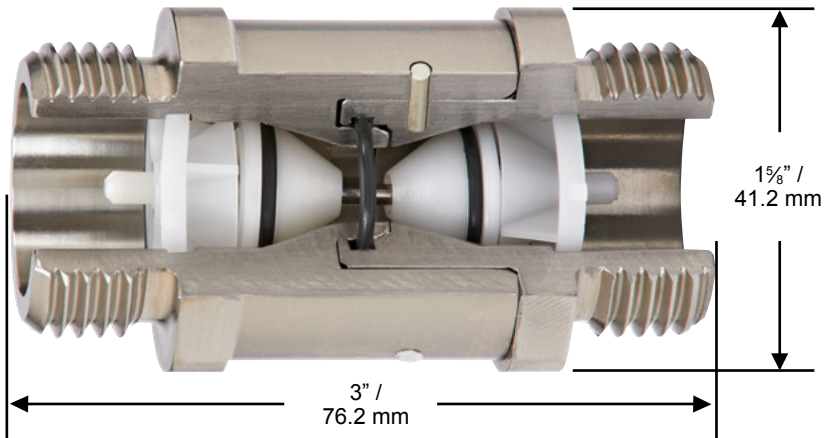

Model 012070/012659



Model 008216

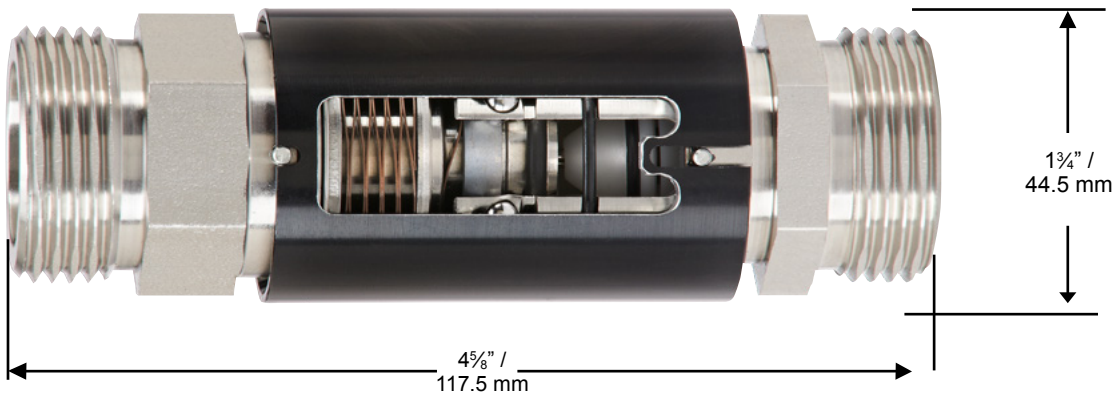

High Volume STB

All Husky® Safe-T-Breaks® stop the flow of fuel on both sides of the separation and have passed the demanding UL test requirements on separations without leaking or failing.

Models 002276, 003076 & 003076A

- Retains UL listing after reconnection
- Internal pressure balancing chamber prevents “line shock” nuisance separations.
- Separates at less than 200 lbf/889.6 N which minimizes “backlash” force of separation, reducing damage to equipment

Model 005231

- Retains UL listing after reconnection
- Uses the same internal pressure balancing chamber as Model 002276
- Separates at less than 115 lbf/511.5 N

Model 005812 & 006914

- Light-weight, inexpensive and disposable
- Same instant-closing dual poppet check valve design as Model 002276
- Separates at less than 300 lbf/1334.4 N

Model 006301

- Internal Pressure Compensating Chamber (PCC) that prevents “line shock” nuisance separations
- Same instant-closing dual poppet check valve as Model 002276
- Separates at less than 225 lbf/1000.8 N

Models 015176 & 015254

- Internal Pressure Compensating Chamber (PCC) that prevents “line shock” nuisance separations
- Same instant-closing dual poppet check valve as Model 002276
- Features a pre-loaded spring and a single turn wave spring that enables valve to resist fatigue from repeated hose stretching
- Separates using ball bearings and latch ring at less than 250 lbf/1,112.1 N

Reconnectable with NPT

MODEL NO.	DESCRIPTION	SHIPPING WEIGHT LBS (KG)
002276	1" F x 1" F Reconnectable Safe-T-Break®	.75 (.34)
005231	1" F x 1" F Reconnectable Low-Pull Safe-T-Break®	.75 (.34)

Non-reconnectable with NPT

MODEL NO.	DESCRIPTION	SHIPPING WEIGHT LBS (KG)
005812	1" F x 1" F Non-Reconnectable Safe-T-Break®	.61 (.27)
006301	1" F x 1" F PCC Non-Reconnectable Safe-T-Break®	.69 (.31)
015176	1" F x 1" F Super STB 1" Non-Reconnectable	.75 (.34)

Reconnectable with BSP

MODEL NO.	DESCRIPTION	SHIPPING WEIGHT LBS (KG)
003076	1" F x 1" F Reconnectable Safe-T-Break®	.75 (.34)
003076A	1" F x 1" F Reconnectable Safe-T-Break® - Atex	.75 (.34)

Non-reconnectable with BSP

MODEL NO.	DESCRIPTION	SHIPPING WEIGHT LBS (KG)
006914	1" F x 1" F Non-Reconnectable Safe-T-Break®	.61 (.27)
015254	1" F x 1" F Super STB 1" Non-Reconnectable	.75 (.34)

Construction

Reconnectable Safe-T-Breaks®	
Body	Aluminum
Seals	Fluorocarbon
Springs	Stainless Steel Stainless steel load and latch spring reverse mechanism Hardened stainless steel latch ring and balls
Non-Reconnectable Safe-T-Breaks®	
Body	Aluminum



Model 002276

Model 005812

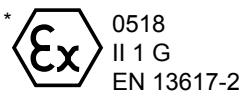

WARNING: Cancer and Reproductive Harm - www.P65Warnings.ca.gov

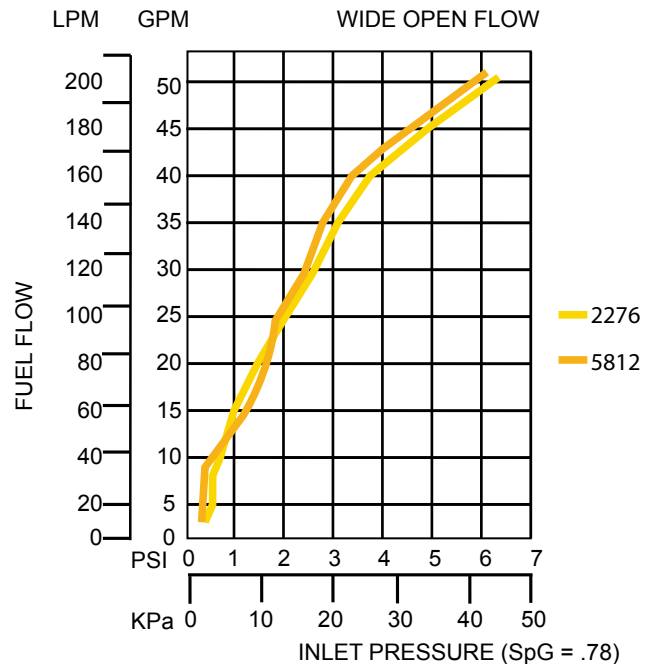

High Volume STB

All Husky® Safe-T-Breaks® stop the flow of fuel on both sides of the separation and have passed the demanding UL test requirements on separations without leaking or failing.

Dimensions and System Options

Guards

MODEL NO.	DESCRIPTION
003098**	Safe-T-Break® Scuff Guard

Accessories, Maintenance, and Testing

MODEL NO.	DESCRIPTION
007000	Safe-T-Break® Drain Cup
003813	Safe-T-Break® Demonstration Kit

Guard Color Chart

COLOR	SUFFIX	COLOR	SUFFIX	COLOR <i>CUSTOM</i>	SUFFIX
Blue	-01	Gold	-08	Amoco Blue	-07 <i>CUSTOM</i>
Red	-02	Silver	-09	Apple Green	-18 <i>CUSTOM</i>
Green	-03	BP Green	-16	Purple	-19 <i>CUSTOM</i>
Black	-04	M Blue	-25	Pink	-20 <i>CUSTOM</i>
Yellow	-05	Orange	-39	BPS Green	-22 <i>CUSTOM</i>
White	-06				

Scuff Guards are to be ordered with the corresponding guard color option added to the model number. Example: If BLUE guards are desired, add guard color option -01 to the model number (159504-01). For custom colors, a minimum order of 4,000 guards will be required.

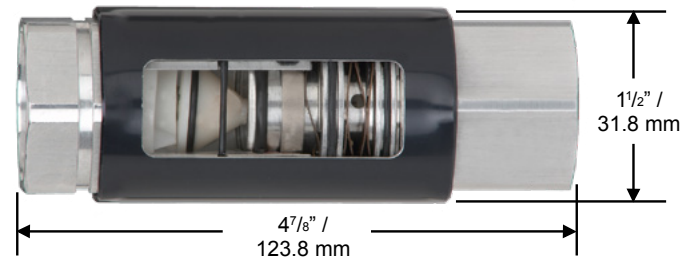
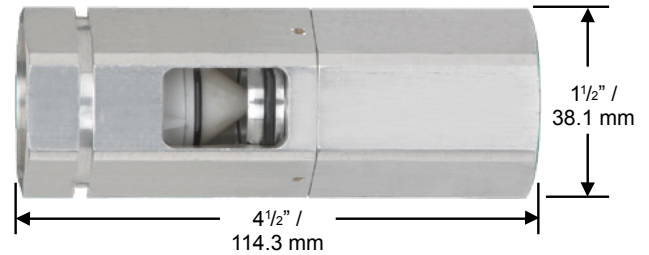

Balance Vapor **STB**

All Husky® Safe-T-Breaks® stop the flow of fuel on both sides of the separation and have passed the demanding UL test requirements on separations without leaking or failing.

Model 3360VR

- Reconnectable Safe-T-Break® for balance vapor recovery systems - coaxial hoses with fuel on the “inside”, vapor return on the “outside”
- Unique in-line latching mechanism requires less force to reconnect Safe-T-Break® after a separation
- Unique vapor valve stops vapors from escaping after a drive away.
- Separates at less than 200 lbf/889.6 N to minimize backlash damage
- Patented wave spring design minimizes nuisance breaks

Model 005900

- Non-reconnectable Safe-T-Break® for balance vapor recovery systems - coaxial hoses with fuel on the “inside”, vapor return on the “outside”
- Internal pressure compensating chamber isolates shear pin from line shock preventing nuisance breaks.
- Separates at less than 250 lbf/1112.1 N to minimize backlash damage
- Same built-in vapor valve as Model 3360VR

Reconnectable

MODEL NO.	DESCRIPTION	SHIPPING WEIGHT LBS (KG)
3360VR**	Reconnectable Safe-T-Break®	1.3 (.5)

Non-reconnectable

MODEL NO.	DESCRIPTION	SHIPPING WEIGHT LBS (KG)
005900**	Non-Reconnectable Safe-T-Break®	1.2 (.5)

**See page 2 for guard color options

Construction

Body	Aluminum
Seals	Fluorocarbon
Springs	Stainless Steel
Threads	1 ⁷ / ₈ " x 12
Stainless steel load and latch spring reverse mechanism	
Hardened stainless steel latch ring and balls	



Model 3600VR



Model 005900

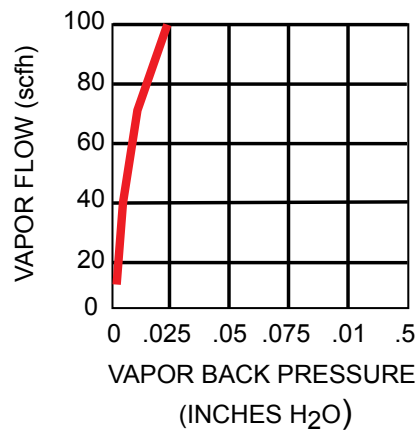

CALIFORNIA AIR RESOURCES



Texas Commission on Environmental Quality



Missouri Department of Natural Resources

WARNING: Cancer and Reproductive Harm - www.P65Warnings.ca.gov

Balance Vapor **STB**

All Husky® Safe-T-Breaks® stop the flow of fuel on both sides of the separation and have passed the demanding UL test requirements on separations without leaking or failing.

Dimensions and System Options

Guards

MODEL NO.	DESCRIPTION
003990**	Scuff Guard for 3360VR Safe-T-Break®
005895**	Scuff Guard for 005900 Safe-T-Break®

Accessories, Maintenance, and Testing

MODEL NO.	DESCRIPTION
007000	Safe-T-Break® Drain Cup

Guard Color Chart

COLOR	SUFFIX	COLOR	SUFFIX	COLOR <i>CUSTOM</i>	SUFFIX
Blue	-01	Gold	-08	Amoco Blue	-07 <i>CUSTOM</i>
Red	-02	Silver	-09	Apple Green	-18 <i>CUSTOM</i>
Green	-03	BP Green	-16	Purple	-19 <i>CUSTOM</i>
Black	-04	M Blue	-25	Pink	-20 <i>CUSTOM</i>
Yellow	-05	Orange	-39	BPS Green	-22 <i>CUSTOM</i>
White	-06				

Scuff Guards are to be ordered with the corresponding guard color option added to the model number. Example: If BLUE guards are desired, add guard color option -01 to the model number (159504-01). For custom colors, a minimum order of 4,000 guards will be required.

Model 3360VR

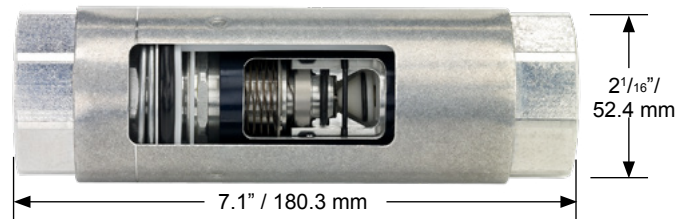

Model 005900

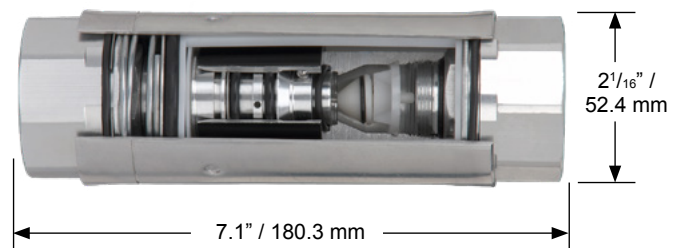

Vacuum Assist **STB**

All Husky® Safe-T-Breaks® stop the flow of fuel on both sides of the separation and have passed the demanding UL test requirements on separations without leaking or failing.

Model 004034

- Reconnectable Safe-T-Break® for the vapor assist systems: coaxial hoses with fuel “outside” hose, vapor return “inside” hose
- EVR Certified per CARB CP-201
- Meets the reconnect endurance test of the UL Standard 567
- Unique vapor valve stops vapors from escaping after a drive away.
- Separates at less than 200 lbf/889.6 N to minimize backlash damage
- Unique pre-loaded shock absorbing wave spring minimizes nuisance breaks.

Models 004034A/005134A

- Separates between 180-337 lbf/800-1500 N

Model 006560

- Reconnectable Safe-T-Break in the same style and design as the Model 004034 including the same fuel/vapor paths and separation force
- 1-1/4” X 18 threads
- EVR Certified per CARB CP-201

Model 005134

- Non-reconnectable Safe-T-Breaks® in the same style and design as Model 004034, including the same fuel/vapor paths and separation force
- EVR Certified per CARB CP-201

Model 015377

- Non-reconnectable Safe-T-Breaks® in the same style and design as Model 006560, including the same fuel/vapor paths and separation force
- EVR Certified per CARB CP-201

Reconnectable

MODEL NO.	DESCRIPTION	SHIPPING WEIGHT LBS (KG)
004034	Reconnectable Safe-T-Break®	1.0 (.45)
004034A*	Reconnectable Safe-T-Break® - Atex	1.0 (.45)
006560	Reconnectable Safe-T-Break® for 1-1/4” THREADS	1.0 (.45)

Non-reconnectable

MODEL NO.	DESCRIPTION	SHIPPING WEIGHT LBS (KG)
005134	Non-reconnectable Safe-T-Break®	1.0 (.45)
005134A*	Non-reconnectable Safe-T-Break® - Atex	1.0 (.45)
015377	Non-reconnectable Safe-T-Break® 1-1/4”	1.0 (.45)

Construction

Body	Aluminum
Seals	Fluorocarbon
Springs	Stainless Steel
Springs	Stainless Steel
	Stainless steel load and latch spring reverse mechanism
	Hardened stainless steel latch ring and balls
Threads	004034, 004034A, 005134 and 005134A = M34 x 1.5 006560 and 15377= 1-1/4” x 18

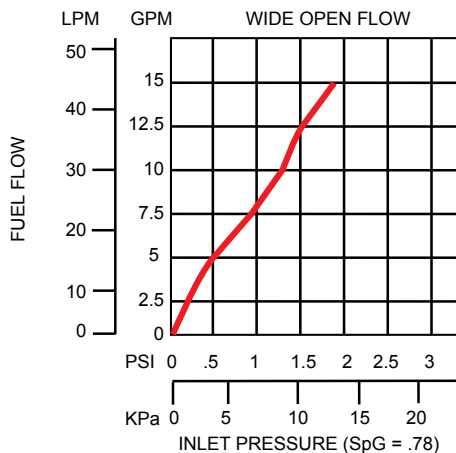
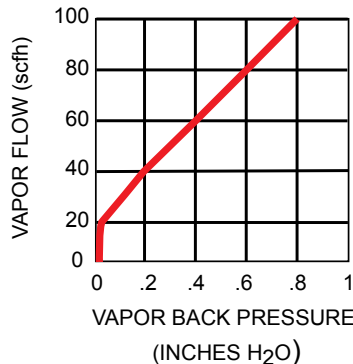

Model 004034



Model 005134



! WARNING: Cancer and Reproductive Harm - www.P65Warnings.ca.gov

Vacuum Assist **STB**

All Husky® Safe-T-Breaks® stop the flow of fuel on both sides of the separation and have passed the demanding UL test requirements on separations without leaking or failing.

Dimensions and System Options

Guards

Model No.	Description
003098**	Scuff Guard for 004034, 004034A, 005134, 005134A and 006560 Safe-T-Breaks®

Guard Color Chart

COLOR	SUFFIX	COLOR	SUFFIX	COLOR <i>CUSTOM</i>	SUFFIX
Blue	-01	Gold	-08	Amoco Blue	-07 <i>CUSTOM</i>
Red	-02	Silver	-09	Apple Green	-18 <i>CUSTOM</i>
Green	-03	BP Green	-16	Purple	-19 <i>CUSTOM</i>
Black	-04	M Blue	-25	Pink	-20 <i>CUSTOM</i>
Yellow	-05	Orange	-39	BPS Green	-22 <i>CUSTOM</i>
White	-06				

Scuff Guards are to be ordered with the corresponding guard color option added to the model number. Example: If BLUE guards are desired, add guard color option -01 to the model number (159504-01). For custom colors, a minimum order of 4,000 guards will be required.

Model 004034



Model 005134

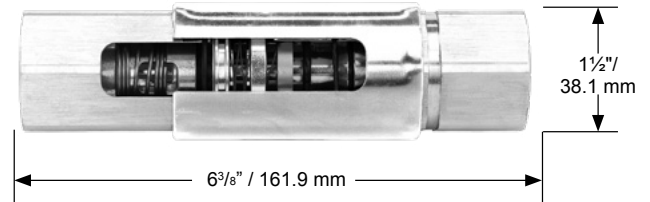

Model 006560



Model 015377

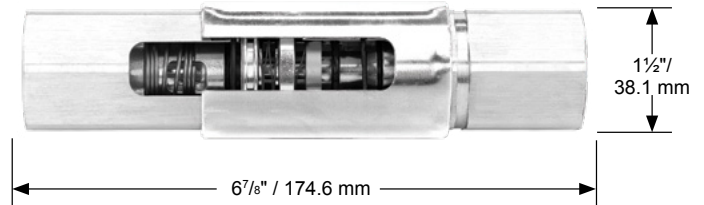

E85 Safe-T-Breaks®

All Husky® Safe-T-Breaks® stop the flow of fuel on both sides of the separation.

- Compatible with unleaded, diesel and all Ethanol blends through E85
- Unit is lightweight, inexpensive and disposable.
- Features same instant closing dual poppet check valve design as Model 006360
- Maximum separation of 300 lbf/1334.5 N



Model 006273

E85 Safe-T-Breaks®

MODEL NO.	DESCRIPTION	SHIPPING WEIGHT LBS (KG)
006273	¾" F x ¾" F Standard Non-Reconnectable Safe-T-Break®	.30 (.13)

Construction

Body	Aluminum with Electroless Nickel Plating
Seals	Fluorocarbon
Springs	Stainless Steel
Threads	¾" / 19.1 mm NPT

006273

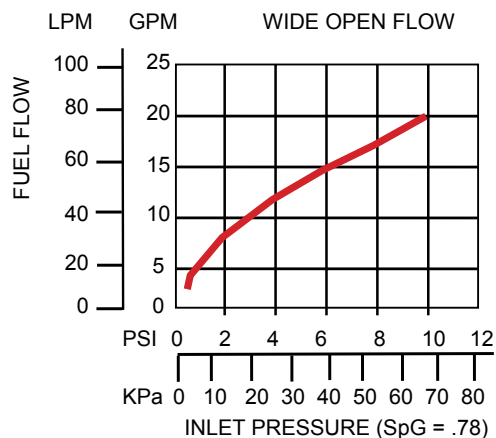

WARNING: Cancer and Reproductive Harm - www.P65Warnings.ca.gov

E85 Safe-T-Breaks®

All Husky® Safe-T-Breaks® stop the flow of fuel on both sides of the separation.

Dimensions and System Options

Accessories, Testing and Maintenance

MODEL NO.	DESCRIPTION
007000	Safe-T-Break® Drain Cup
003813	Safe-T-Break® Demonstration Kit

Model 006273

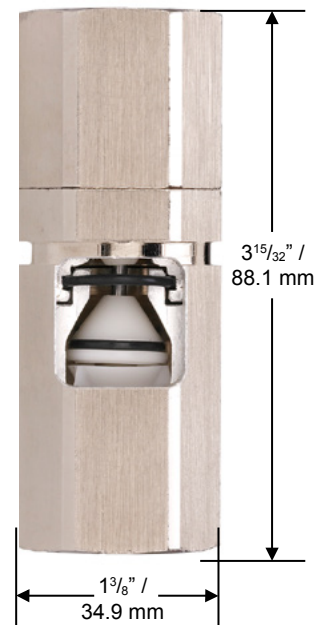

VAC Assist MAGBREAK®

SAFE-T-BREAKS®

All Husky® Safe-T-Breaks® stop the flow of fuel on both sides of the separation and have passed the demanding UL test requirements on separations without leaking or failing.

- EVR Certified per CAB CP-201
- High impact resistant polymer housing
- Two straight screwdrivers used to separate for easier install and maintenance on other hanging hardware.
- Assurance of proper reconnection using a simple "twist of lock" feature
- Low scuff housing
- Stops flow on both sides of break
- Reconnectable Safe-T-Break® for the vapor assist systems: coaxial hoses with fuel "outside" hose, vapor return "inside" hose
- Unique vapor valve stops vapors from escaping after a drive away.
- Separates at less than 225 lbs/1000.9 N to minimize backlash damage



Vac Assist MAGBREAK®

MODEL NO.	DESCRIPTION	SHIPPING WEIGHT LBS (KG)
008332	MAGBREAK® Coax M34 CK	1.36 (.62)
014592	MAGBREAK® Coax 1.25	1.36 (.62)

Construction

Body	Aluminum
Seals	Fluorocarbon
Springs	Stainless Steel
Threads	8332 = M34 x 1.5 and 14592 = 1-1/4" x 18

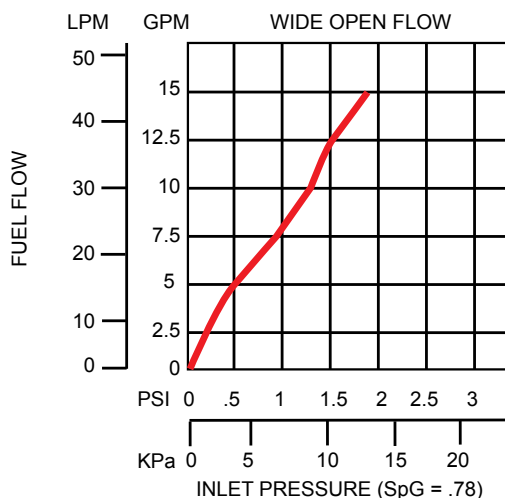
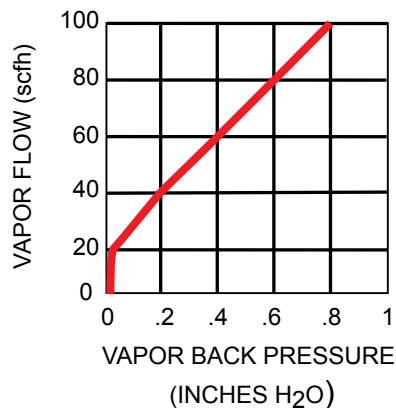

WARNING: Cancer and Reproductive Harm - www.P65Warnings.ca.gov

VAC Assist MAGBREAK®

All Husky® Safe-T-Breaks® stop the flow of fuel on both sides of the separation and have passed the demanding UL test requirements on separations without leaking or failing.

Dimensions and System Options

Replacement Parts

MODEL NO.	DESCRIPTION
008632	MAGBREAK LOWER HALF 008332
015416	MAGBREAK LOWER HALF 014592

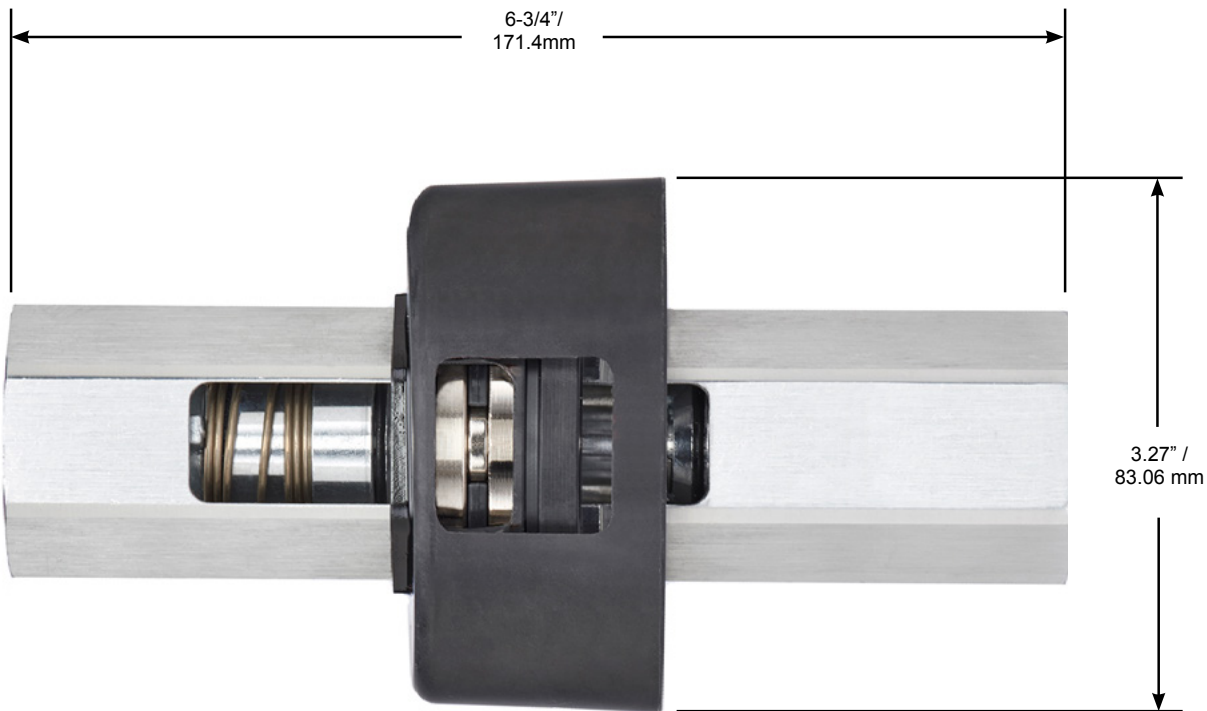

E25 Safe-T-Breaks®

All Husky® Safe-T-Breaks® stop the flow of fuel on both sides of the separation.

- Compatible with unleaded, diesel and all Ethanol blends through E25
- Retains the UL listing after being reconnected
- Unusual interface between a pre-loaded spring and a single turn wave spring that enables valve to resist sudden pressure build-up in the hose resulting in nuisance separations
- Unit separates at less than 200 lbf/889.6 N which minimizes “backlash” force of separation, reducing damage to equipment



E25 Safe-T-Breaks®

MODEL NO.	DESCRIPTION	SHIPPING WEIGHT LBS (KG)
006360	¾" F x ¾" F Reconnectable Safe-T-Break®	.58 (.26)

Construction

Body	Aluminum with Electroless Nickel Plating
Seals	Fluorocarbon and Fluorosilicone
Springs	Stainless Steel Stainless steel load and latch spring reverse mechanism Hardened stainless steel latch ring and ball
Threads	¾" / 19.1 mm NPT

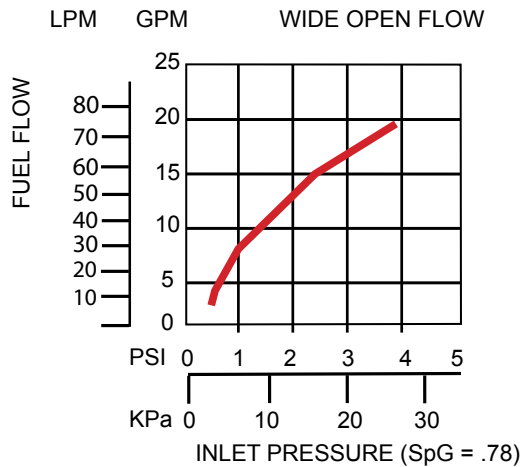

WARNING: Cancer and Reproductive Harm - www.P65Warnings.ca.gov

E25 Safe-T-Breaks®

All Husky® Safe-T-Breaks® stop the flow of fuel on both sides of the separation.

Dimensions and System Options

Guards

MODEL NO.	DESCRIPTION
003096	006360 Scuff Guard

Accessories, Testing and Maintenance

MODEL NO.	DESCRIPTION
007000	Safe-T-Break® Drain Cup
003813	Safe-T-Break® Demonstration Kit

Model 006360

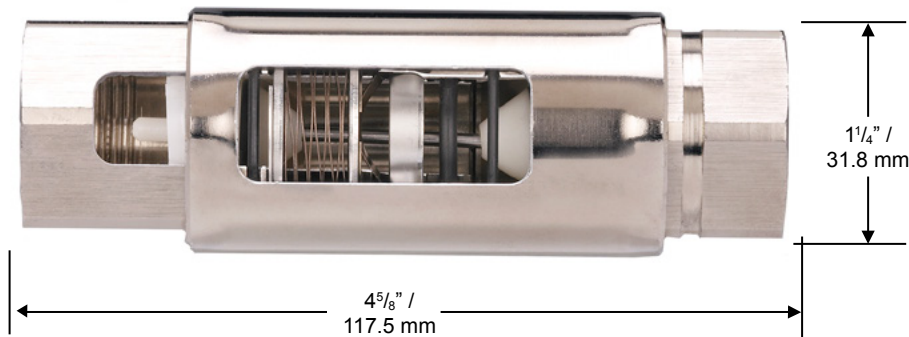

Inline STB

All Husky® Safe-T-Breaks® stop the flow of fuel on both sides of the separation and have passed the demanding UL test requirements on separations without leaking or failing.

- Threads directly into nozzle inlet
- Separates at 180-337 lbs (800-1500N)
- Reconnectable
- Stops flow on hose side of break
- Separates at angles up to 90 degrees
- Aluminum internal flow director - stronger than Elaflex plastic design
- Check valve o-ring to ensure reliable fuel shut-off, not included on Elaflex

New Inline SAFE-T-BREAK®

MODEL NO.	DESCRIPTION	SHIPPING WEIGHT LBS (KG)
008521A	Inline Safe-T-Break®	.45 (.20)

Construction

Body	Aluminum
Seals	Fluorocarbon
Threads	M34 x 1.5

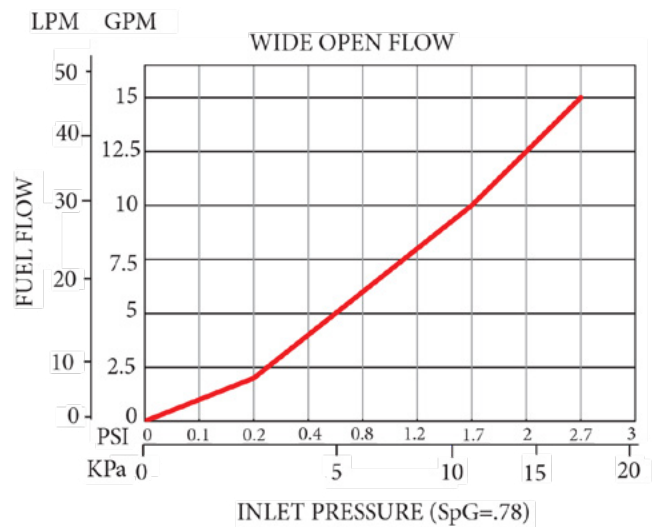

⚠ WARNING: Cancer and Reproductive Harm - www.P65Warnings.ca.gov

Inline STB

All Husky® Safe-T-Breaks® stop the flow of fuel on both sides of the separation and have passed the demanding UL test requirements on separations without leaking or failing.

Dimensions

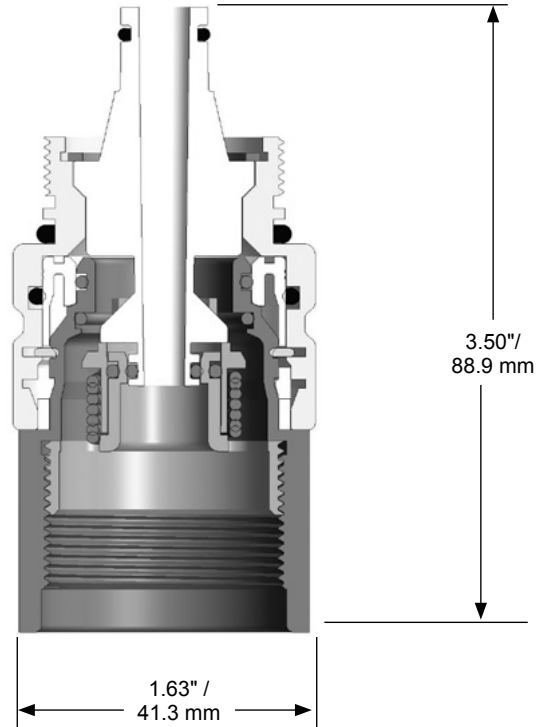

E25/E85 MAGBREAK®

All Husky® Safe-T-Breaks® stop the flow of fuel on both sides of the separation and have passed the demanding UL test requirements on separations without leaking or failing.

- High impact resistant polymer housing
- Compatible with unleaded, diesel, and all Ethanol blends through E85
- Features same separation mechanism as Model 008330
- Lighter than competing magnetic breakaways
- Two straight screwdrivers used to separate
- For easier install and maintenance on other hanging hardware
- Assurance of proper reconnection using a simple “twist to lock” feature
- Absorb line shock in excess of 450 psi at 17 gpm (31 bar at 64.3 Lpm)
- Low scuff housing
- Line shock absorbing design
- Stops flow on both sides of break

G2 E25/E85 MAGBREAK®

MODEL NO.	DESCRIPTION	SHIPPING WEIGHT LBS (KG)
014647	G2 MAGBREAK® 3/4" F x 3/4" F E25/85 NPT (Separates at less than 200 pounds pull force)	1.21 (.55)

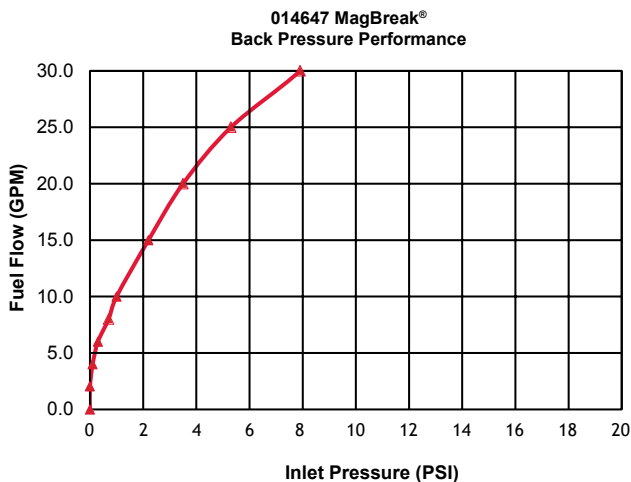

WARNING: Cancer and Reproductive Harm - www.P65Warnings.ca.gov

E25/E85 MAGBREAK®

All Husky® Safe-T-Breaks® stop the flow of fuel on both sides of the separation and have passed the demanding UL test requirements on separations without leaking or failing.

Dimensions

**G2 E25/E85
Magbreak®**

Hex stock 1.25" /
31.75 mm





GENERAL FUELING PRODUCTS

Swivels/STB Combos

Standard Swivel/STB

Husky Model 006310 Swivel Safe-T-Break® combination for standard fueling applications.

- Multi-plane, full 360° spherical rotation for easy movement of nozzle
- Swivel Sync® feature to prevent separation failure in the 90° position
- Safe-T-Break® is reconnectable and retains UL listing after reconnecting.
- Dual check valves stop fuel in both directions.
- Separates at less than 325 lbf/1,445.6 N which minimizes backlash force of separations, reducing damage to equipment
- Wave spring helps reduce nuisance breaks due to water hammer.
- Dynamic seals have double o-ring construction for long life and low temperature performance.
- Compatible with Ethanol blends though E10
- Compact and light weight for easy handling
- Easier to reconnect when installed at the nozzle
- Eliminates the need for a whip hose

Swivel/Safe-T-Break® Combination

MODEL NO.	DESCRIPTION	SHIPPING WEIGHT LBS (KG)
006310	¾" NPT M x ¾" NPT F Multi-Plane Swivel Reconnectable Safe-T-Break®	.90 (.40)
007085	¾" BSP M x ¾" BSP F Multi-Plane Swivel Reconnectable Safe-t-Break®	.90 (.40)
007085A*	¾" BSP M x ¾" BSP F Multi-Plane Swivel Reconnectable Safe-t-Break® - Atex	.90 (.40)

Construction

Body	Aluminum, Zinc Alloy
Seals	Fluorosilicone, Fluorocarbon
Springs	Stainless Steel
Threads	Various

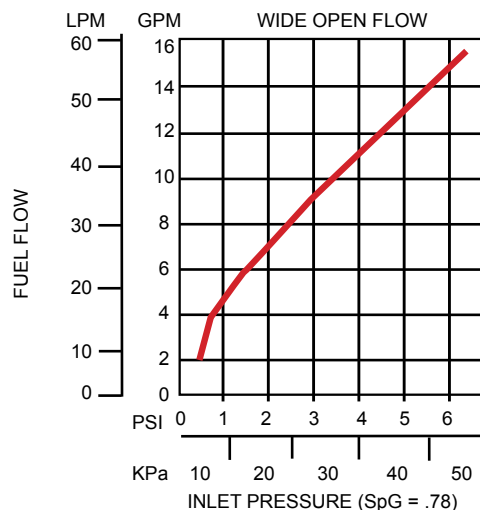

II 2 G
EN 13617-2 TYPE 1
EN 13617-4 STYLE 1



WARNING: Cancer and Reproductive Harm - www.P65Warnings.ca.gov

Standard Swivel/STB

Husky Model 006310 Swivel Safe-T-Break® combination for standard fueling applications.

Dimensions and System Options

Guards

MODEL NO.	DESCRIPTION
006534	Scuff Guard for Safe-T-Break®

Guard Color Chart

COLOR	SUFFIX	COLOR	SUFFIX	COLOR <i>CUSTOM</i>	SUFFIX
Blue	-01	Gold	-08	Amoco Blue	-07 <i>CUSTOM</i>
Red	-02	Silver	-09	Apple Green	-18 <i>CUSTOM</i>
Green	-03	BP Green	-16	Purple	-19 <i>CUSTOM</i>
Black	-04	M Blue	-25	Pink	-20 <i>CUSTOM</i>
Yellow	-05	Orange	-39	BPS Green	-22 <i>CUSTOM</i>
White	-06				

Scuff Guards are to be ordered with the corresponding guard color option added to the model number.
 Example: If BLUE guards are desired, add guard color option -01 to the model number (159504-01).
 For custom colors, a minimum order of 4,000 guards will be required.

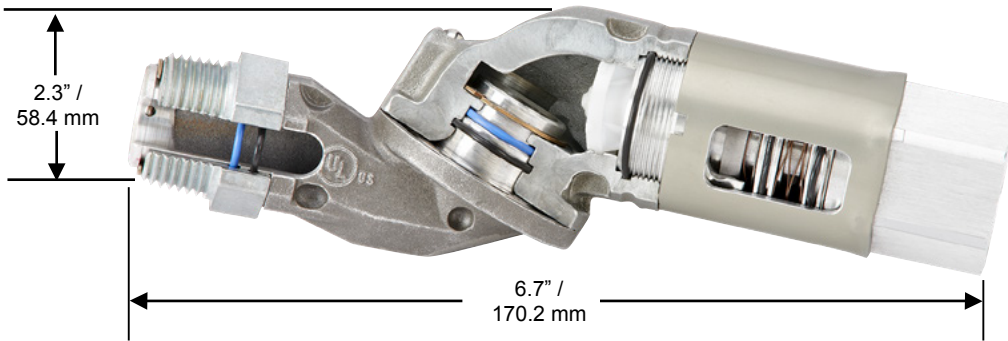

High Volume Swivel/STB

Husky® Model 005969 Swivel Safe-T-Break® Combination for truck and high volume fueling.

- Multi-plane, full 360° spherical rotation for easy movement of nozzle
- Swivel Sync® feature to prevent separation failure in the 90° position.
- High strength step shoulder bearing diameters and impact absorbing stops
- Dynamic seals have double o-ring construction for long life and low temperature performance.
- Separates at less than 325 lbf/1,445.6 N which minimizes backlash force of separations, reducing damage to equipment
- Safe-T-Break® is reconnectable and retains UL listing after reconnecting.
- Dual check valves stop fuel in both directions.
- Internal pressure balancing chamber prevents “line shock” nuisance separations.
- Compatible with Ethanol blends through E10
- Compact and light weight for easy handling
- Easier to reconnect when installed at the nozzle
- Eliminates the need for a whip hose

Swivel/Safe-T-Break® Combination

MODEL NO.	DESCRIPTION	SHIPPING WEIGHT LBS (KG)
005969	1" NPT M x 1" NPT F Multi-Plane Swivel Reconnectable Safe-T-Break®	1.5 (0.7)
008015	1" BSP M x 1" BSP F Multi-Plane Swivel Reconnectable Safe-T-Break®	1.5 (0.7)
008015A*	1" BSP M x 1" BSP F Multi-Plane Swivel Reconnectable Safe-T-Break® - Atex	1.5 (0.7)
008985	1" BSP M x 1" BSP M Multi-Plane Swivel Reconnectable Safe-T-Break®	1.5 (0.7)
008985A*	1" BSP M x 1" BSP M Multi-Plane Swivel Reconnectable Safe-T-Break® - Atex	1.5 (0.7)

Construction

Body	Aluminum, Zinc Alloy
Seals	Fluorocarbon
Springs	Stainless Steel
Threads	Various

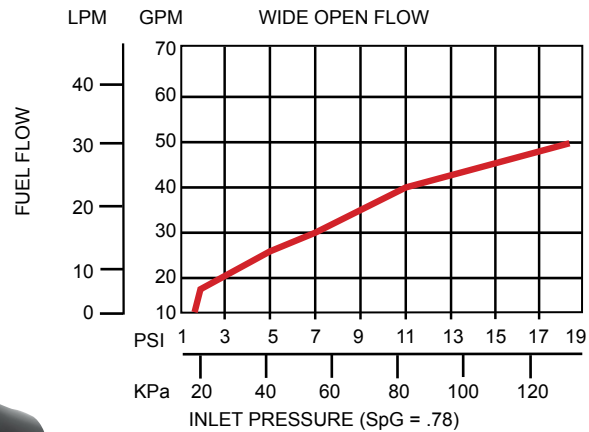

II 2 G
EN 13617-2 TYPE 1
EN 13617-4 STYLE 1

WARNING: Cancer and Reproductive Harm - www.P65Warnings.ca.gov

High Volume Swivel/STB

Husky® Model 005969 Swivel Safe-T-Break® Combination for truck and high volume fueling.

Dimensions and System Options

Guards

MODEL NO.	DESCRIPTION
006534	Scuff Guard for Safe-T-Break®

Accessories, Testing and Maintenance

MODEL NO.	DESCRIPTION
007000	Safe-T-Break® Drain Cup

Guard Color Chart

COLOR	SUFFIX	COLOR	SUFFIX	COLOR <i>CUSTOM</i>	SUFFIX
Blue	-01	Gold	-08	Amoco Blue	-07 <i>CUSTOM</i>
Red	-02	Silver	-09	Apple Green	-18 <i>CUSTOM</i>
Green	-03	BP Green	-16	Purple	-19 <i>CUSTOM</i>
Black	-04	M Blue	-25	Pink	-20 <i>CUSTOM</i>
Yellow	-05	Orange	-39	BPS Green	-22 <i>CUSTOM</i>
White	-06				

Scuff Guards are to be ordered with the corresponding guard color option added to the model number. Example: If BLUE guards are desired, add guard color option -01 to the model number (159504-01). For custom colors, a minimum order of 4,000 guards will be required.

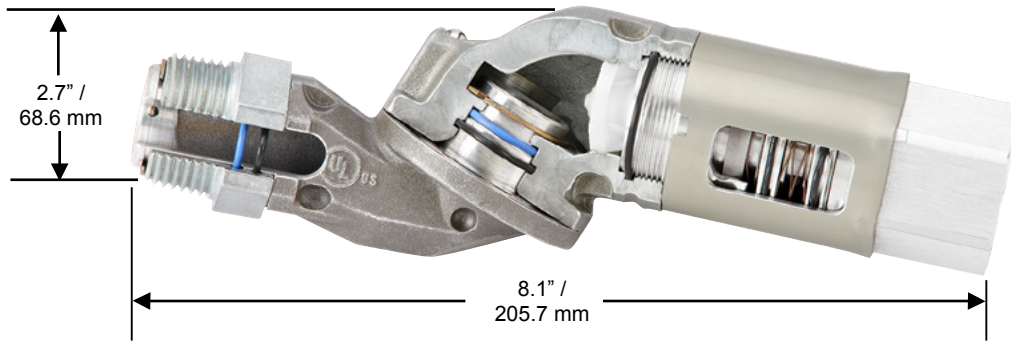

Inline Combo Swivel/STB

Inline combo

- Single Plane 360° Rotation
- Unique to Husky® products, the steel ball bearing design provides easier joint movement during high pressure applications.
- Safe-T-Break® is service reconnectable
- Check valve to stop flow of fuel on hose side
- Check valve O-ring to ensure reliable fuel shut-off
- Separates between 180 lbs. and 337 lbs.
- Separates at angles up to 90°
- Compact and easy to handle
- Fuel/Diesel or DEF versions available



Inline Combo

MODEL NO.	DESCRIPTION	SHIPPING WEIGHT LBS (KG)
012828	3/4" BSP M x 3/4" BSP F, DEF	.90 (.40)
012831	3/4" BSP M x 3/4" NPT F, DEF	.90 (.40)
012887	3/4" BSP M x 1" BSP F, DEF	.90 (.40)
012890	3/4" BSP M x 1" BSP M, DEF	.80 (.36)
013185	M34 M x 1" BSP M, DEF	.80 (.36)
013530A*	1" BSP M x 1" BSP M, Standard Fuel, Atex	.90 (.40)
013827A*	3/4" BSP M x 3/4" BSP M Standard Fuel, Atex	.80 (.36)
014438A*	1" BSP M x 1" BSP M, DEF, Atex	.90 (.40)

Construction

Body	Body: Anodized aluminum / Alodined Aluminum
Seals	Fluorocarbon
Nuts	DEF - Stainless steel, Fuel - electroless nickel-plated steel
Threads	BSP, NPT and M34

1" INLET

WIDE OPEN FLOW

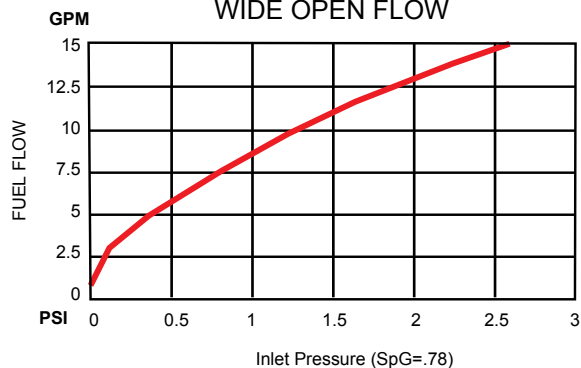

3/4" INLET

WIDE OPEN FLOW

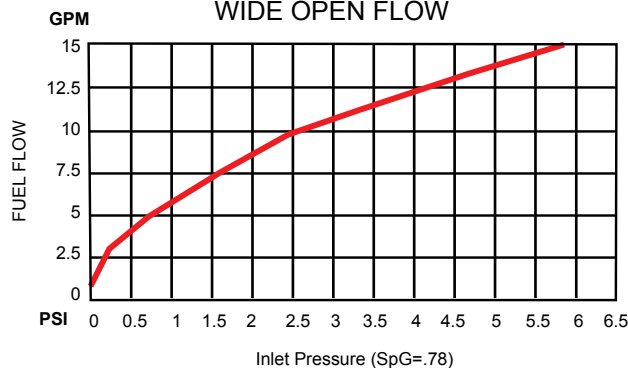

II 1 G
EN13617
Type 2

⚠ WARNING: Cancer and Reproductive Harm - www.P65Warnings.ca.gov

Inline Combo Swivel/STB

Inline combo

Dimensions and System Options

Guards

MODEL NO.	DESCRIPTION
016939	Scuff Guard for Safe-T-Break®

Color Chart

COLOR	SUFFIX	COLOR	SUFFIX
Blue	-01	White	-06
Red	-02	Gold	-08
Green	-03	Silver	-09
Black	-04	BP Green	-16
Yellow	-05	Pink	-20

**Safe-T-Breaks® and Safe-T-Break® Scuff Guards are to be ordered with the corresponding guard color option added to the model number.
 Example: If BLUE guards are desired, add guard color option -01 to the model number (004034-01).
 For custom colors, a minimum order of 4,000 guards will be required.





GENERAL FUELING PRODUCTS

Guards

Husky® Guards

For nozzles and Safe-T-Breaks®



Nozzle Guards

- Nozzle Guards, Nozzle Reguards, Waffle Splash Guards and Safe-T-Break® Guards are to be ordered with the corresponding color option added to the model number.
- Custom colors are available for all Nozzle Guards, Nozzle Reguards, Waffle Splash Guards and Safe-T-Break® Guards.
- The Safety/Warning logo will be printed on all Nozzle Guards and Nozzle Reguards.
- The E85 logo is available on all Nozzle Guards, Nozzle Reguards and Safe-T-Break® Guards upon request.
- A customized logo can be printed on any Nozzle Guard or Nozzle Reguard upon request.

Safe-T-Break® Guards

- Protects dispenser from damage caused by the Safe-T-Break® and whip hose
- Protects the Safe-T-Break® against corrosion due to environmental exposure
- Enhanced protection of the Safe-T-Break® during separations.
- Provides a clean/more streamline appearance
- Available in multiple colors to coordinate with the nozzle guards
- Available with E85 logo

Easy-On Guard Package

MODEL NO.	DESCRIPTION
003440	X, XS®, XFS Nozzles (includes 003795 Mate Nozzle Guard and 012117 Fluted Handle Cover)
011597	V34 International Nozzles (includes 014526 Mate Nozzle Guard and 010089 Handle Cover)
014524	X, XS®, XFS International Nozzles (includes 014530 Mate Nozzle Guard and 007361 Handle Cover)

Full Grip Nozzle Guards

MODEL NO.	DESCRIPTION
000554	1A, 1GS, 1HS Nozzles
004145	X, XS®, XFS Nozzles
004740	VIII, VIIS Nozzles
005170	V3 Nozzles
006483	Safe-T-Squeeze® Nozzles
006951	V34 Nozzles

Full Grip Nozzle Reguards (includes zip tie)

MODEL NO.	DESCRIPTION
001804	1A, 1GS, 1HS Nozzles
001806	X, XS®, XFS Nozzles
005516	VIII, VIIS Nozzles
004231	V34 Nozzles
005169	V3 Nozzles

Nozzle Guard Packages

MODEL NO.	DESCRIPTION
000099	1A, 1HS Nozzle Protection Package (includes 000554 Full Grip Nozzle Guard and 001808 Waffle Splash Guard)
001506	X, XS® Nozzle Protection Package (includes 004145 Full Grip Nozzle Guard and 001808 Waffle Splash Guard)
001809	X, XS® Nozzle Reguard Package (includes 001806 Full Grip Reguard, Zip Tie and 001808 Waffle Splash Guard)
001811	1A, 1HS Nozzle Reguard Package (includes 001804 Full Grip Reguard, Zip Tie and 001808 Waffle Splash Guard)

Waffle Splash Guards

MODEL NO.	DESCRIPTION
001807	Waffle Splash Guard (small hole)
001808	X, XS®, 1A, 1HS, VIII, VIIS Nozzles
006955	V3 Nozzles

Safe-T-Break® Guards

MODEL NO.	DESCRIPTION
003096	003360, 006130, and 005230 Safe-T-Breaks®
003098	002276, 004034, 005134, 006210, 006301, and 006560 Safe-T-Breaks®
003990	003360VR Safe-T-Break®
006534	006310 Swivel Safe-T-Break® Combo
006503	2 piece Safe-T-Break® Dispenser Guard
006570	2 piece Safe-T-Break® Dispenser Guard with E85 logo

Mate Nozzle Guards

MODEL NO.	DESCRIPTION
000226	1A, 1GS, 1HS, DEF Nozzles
003795	X, XS®, XFS Nozzles
007295	1A, 1GS, 1HS, DEF Handle Cover
007361	X, XS®, XFS, DEF X, PHG Handle Cover
010089	V34, PHG Handle Cover
012117	X, XS®, XFS Fluted Handle Cover
014526	V34 International Nozzles
014530	X, XS®, XFS International Nozzles
015257	1A, 1GS, 1HS, DEF International Nozzles



WARNING: Cancer and Reproductive Harm - www.P65Warnings.ca.gov

Husky® Guards

For nozzles and Safe-T-Breaks®



Guard Color Chart

COLOR	SUFFIX	COLOR	SUFFIX	COLOR <i>CUSTOM</i>	SUFFIX
Blue	-01	Gold	-08	Amoco Blue	-07 <i>CUSTOM</i>
Red	-02	Silver	-09	Apple Green	-18 <i>CUSTOM</i>
Green	-03	BP Green	-16	Purple	-19 <i>CUSTOM</i>
Black	-04	M Blue	-21	Pink	-20 <i>CUSTOM</i>
Yellow	-05	Orange	-39	BPS Green	-22 <i>CUSTOM</i>
White	-06				

Scuff Guards are to be ordered with the corresponding guard color option added to the model number.
 Example: If BLUE guards are desired, add guard color option -01 to the model number (159504-01).
 For custom colors, a minimum order of 4,000 guards will be required.

POPD Guards

For nozzles and Safe-T-Breaks®

- Allows additional advertising at the point of fuel purchases
- Unique angled design for easy readability both hanging in dispenser and while fueling
- Guards come standard with clear cover to protect the advertisement.
- Clear cover contains UV stabilizer for durability and to prevent discoloring.
- Built-in to the nozzle guard for easy installation



Full Grip Nozzle Guards

MODEL NO.	DESCRIPTION
006665	X, XS®, XFS Nozzles
006655	1A, 1HS, 1GS Nozzles
007352	VIII, VIIS Nozzles
006660	V34 Nozzles
007175	11A Nozzles
007180	11B Nozzles
008183	1A, 1GS, 1HS, Nozzles
008184	V34 Nozzle
008185	X, XS®, XFS Nozzles
008186	VIII, VIIS, Nozzles
008187	11A Nozzles
008188	11B Nozzles

Full Grip Nozzle Reguards

MODEL NO.	DESCRIPTION
007205	X, XS®, XFS Nozzles
007210	1A, 1HS, 1GS Nozzles
007220	V34 Nozzles
007225	11A Nozzles
007230	11B Nozzles
008194	VIII, VIIS Nozzles
008190	1A, 1GS, 1HS Nozzles
008191	V34 Nozzle
008192	X, XS®, XFS Nozzles
008193	VIII, VIIS Nozzles
008195	11A Nozzles
008196	11B Nozzles

Clear Cover

MODEL NO.	DESCRIPTION
006628	POPD S Clear Cover
008181	POPD H Clear Cover

EZ Guards

MODEL NO.	DESCRIPTION
008179	1A, 1GS, 1HS Nozzles
008175	X, XS®, XFS Nozzles
008177	VIII, VIIS Nozzles
007990	11A Nozzles
007992	11B Nozzles
008180	1A, 1GS, 1 HS Nozzles
008176	X, XS®, XFS Nozzles
008178	VIII, VIIS Nozzles
007991	11A Nozzles
007993	11B Nozzles

POPD Guards

For nozzles and Safe-T-Breaks®

System Options

Mate Nozzle Guards

MODEL NO.	DESCRIPTION
008169	1A, 1GS, 1HS Nozzles
008165	X, XS®, XFS Nozzles
008167	VIII, VIIS Nozzles
008171	11A Nozzles
008173	11B Nozzles
008170	1A, 1GS, 1HS Nozzles
008166	X, XS®, XFS Nozzles
008168	VIII, VIIS Nozzles
008172	11A Nozzles
008174	11B Nozzles
015247	X,XS International Polymer Handguard Nozzles
015253	X,XS International Polymer Handguard Nozzles without Clear Cover

Black Handle Cover

MODEL NO.	DESCRIPTION
007361	X,XS,XFS Polymer Handguard Nozzles
007376	1A, 1HS, 1GS and DEF Nozzles
012117	X,XS,XFS Metal Handguard Nozzles

Waffle Splash Guard

MODEL NO.	DESCRIPTION
001808	X, XS®, 1A, 1HS, VIII, VIIS Nozzles
001807	11A, 11B Nozzles

Guard Color Chart

COLOR	SUFFIX	COLOR	SUFFIX	COLOR <i>CUSTOM</i>	SUFFIX
Blue	-01	Gold	-08	Amoco Blue	-07 <i>CUSTOM</i>
Red	-02	Silver	-09	Apple Green	-18 <i>CUSTOM</i>
Green	-03	BP Green	-16	Purple	-19 <i>CUSTOM</i>
Black	-04	M Blue	-21	Pink	-20 <i>CUSTOM</i>
Yellow	-05	Orange	-39	BPS Green	-22 <i>CUSTOM</i>
White	-06				

Scuff Guards are to be ordered with the corresponding guard color option added to the model number.
 Example: If BLUE guards are desired, add guard color option -01 to the model number (159504-01).
 For custom colors, a minimum order of 4,000 guards will be required.





GENERAL FUELING PRODUCTS

Spouts

X, XS[®] Spouts

Spout assemblies

- Stainless Steel Spout Bushing (optional on LDD)
- *Streamshaper*[®]
- Keeps spout tip round
- Reduces turbulence for straighter fuel flow and less splashback spillage



Unloaded Spout Assembly



Light-Duty Diesel Spout Assembly

Unloaded Spout Assemblies

MODEL NO.	DESCRIPTION	SHIPPING WEIGHT LBS (KG)
001473	X, XS [®] , 1A, 1GS Spout Assembly with Streamshaper [®]	.3 (.14)
008684	X, XS [®] , 1A, 1GS MTBE Spout Assembly with Streamshaper [®]	.3 (.14)
010432	X, XS [®] , 1A, 1GS Long Spout Assembly with Streamshaper [®]	.4 (.18)
014376	X, XS [®] , 1A, 1GS Spout Assembly without Spout Spring, with Streamshaper [®]	.4 (.18)
014420	X, XS [®] , 1A, 1GS Spout Assembly with Streamshaper [®] and Spout Ring	.4 (.18)

Light Duty Diesel Spout Assemblies

MODEL NO.	DESCRIPTION	SHIPPING WEIGHT LBS (KG)
001471	X, XS [®] , 1A, 1GS Spout Assembly with Streamshaper [®]	.4 (.18)
014378	X, XS [®] , 1A, 1GS Spout Assembly without Spout Spring, with Streamshaper [®]	.4 (.18)
014421	X, XS [®] , 1A, 1GS Spout Assembly with Streamshaper [®] and Spout Ring	.4 (.18)



 WARNING: Cancer and Reproductive Harm - www.P65Warnings.ca.gov

X, XS[®] Spouts

Spout assemblies

Dimensions

Unleaded Spouts

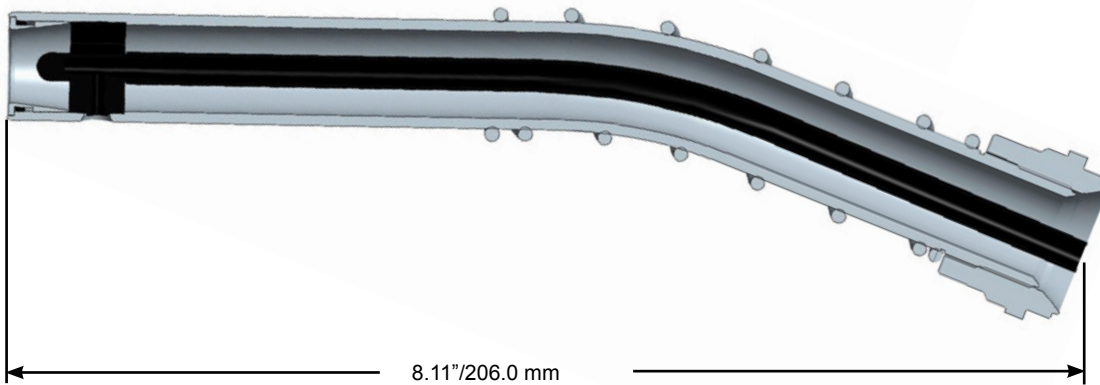
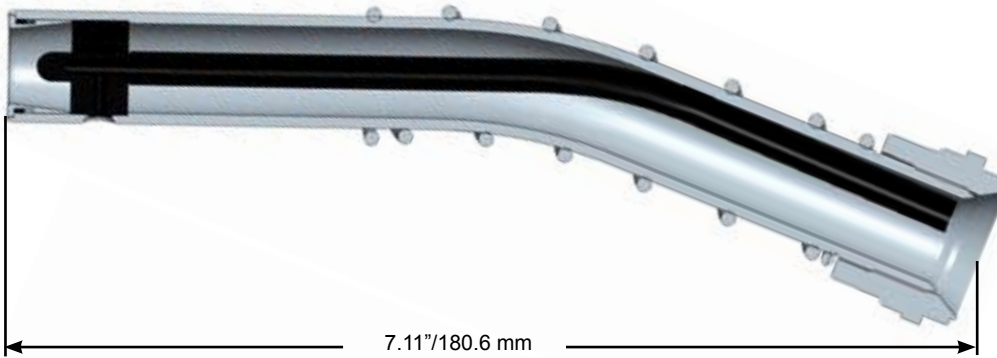

Light Duty Diesel Spout

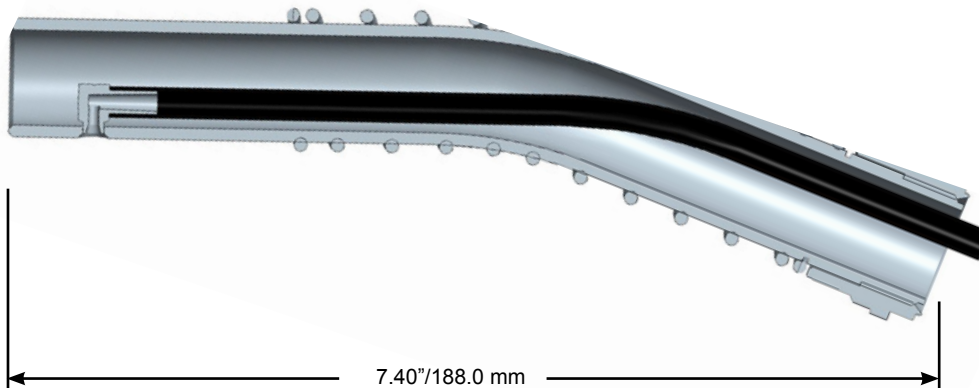

1GS Spouts

Spout assemblies

- Stainless Steel Spout Bushing (optional on LDD)
- *Streamshaper*®
- Keeps spout tip round
- Reduces turbulence for straighter fuel flow and less splashback spillage



Unleaded Spout Assemblies

MODEL NO.	DESCRIPTION	SHIPPING WEIGHT LBS (KG)
001473	X, XS®, 1A, 1GS Spout Assembly with Streamshaper®	.3 (.14)
003356	XFS Spout Assy with Hanging Hook and Streamshaper®	.5 (.23)
008684	X, XS®, 1A, 1GS MTBE Spout Assembly with Streamshaper®	.3 (.14)
010432	X, XS®, 1A, 1GS Long Spout Assembly with Streamshaper®	.4 (.18)
014376	X, XS®, 1A, 1GS Spout Assembly without Spout Spring, with Streamshaper®	.4 (.18)
014420	X, XS®, 1A, 1GS Spout Assembly with Streamshaper® and Spout Ring	.4 (.18)

Light Duty Diesel Spout Assemblies

MODEL NO.	DESCRIPTION	SHIPPING WEIGHT LBS (KG)
001471	X, XS®, 1A, 1GS Spout Assembly with Streamshaper®	.4 (.18)
003358	XFS Spout Assembly with Hanging Hook	.6 (.27)
014378	X, XS®, 1A, 1GS Spout Assembly without Spout Spring, with Streamshaper®	.4 (.18)
014421	X, XS®, 1A, 1GS Spout Assembly with Streamshaper® and Spout Ring	.4 (.18)

High Flow/High Volume Spout Assemblies

MODEL NO.	DESCRIPTION	SHIPPING WEIGHT LBS (KG)
005215	1HS, 1GS Spout Assembly	.4 (.18)



 WARNING: Cancer and Reproductive Harm - www.P65Warnings.ca.gov

1GS Spouts

Spout assemblies

Dimensions

Unleaded Spouts

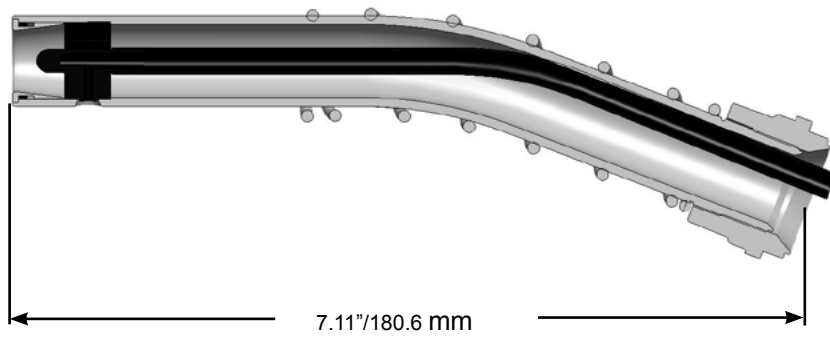

Light Duty Diesel Spout

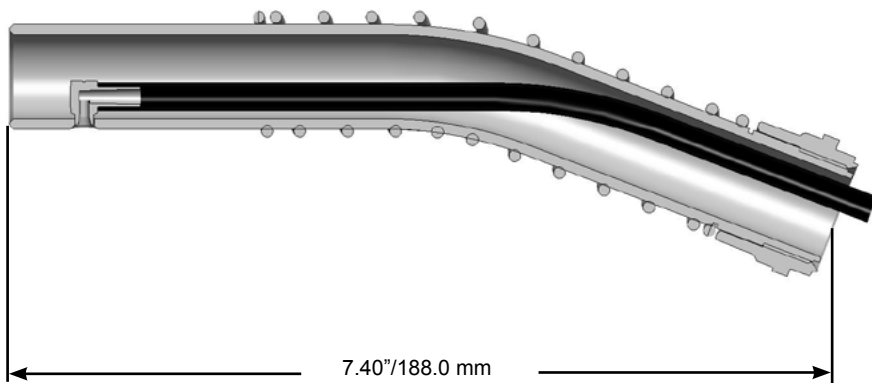

High Flow/High Volume Spout

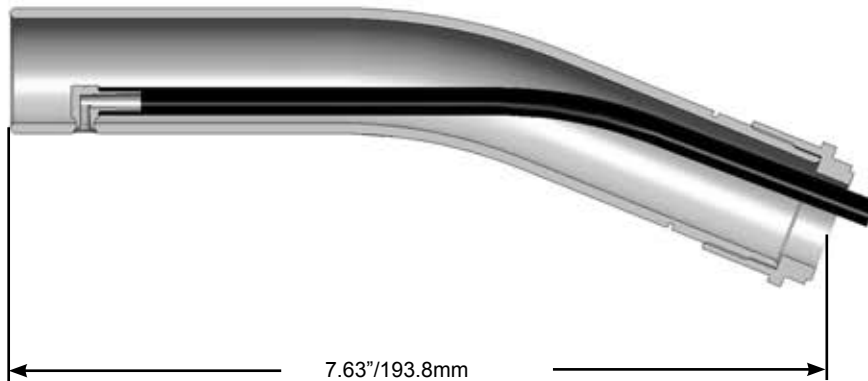

DEF Spouts

Spout assemblies

- Spout assemblies with the *StreamShaper*® reduces turbulence for straighter DEF flow and less splash back spillage.
- Spout assemblies with the Flo-Stop® device that shuts off the nozzle if it falls from the fill tank or raises above the horizontal.
- Spout assemblies with the Accufuel® safety feature prevents misfilling of DEF in the diesel tank.

Stainless Steel DEF Nozzle Spout Assemblies

MODEL NO.	DESCRIPTION	SHIPPING WEIGHT LBS (KG)
007360	with Spout Ring and Flo-Stop®	.4 (.18)
007362	with Flo-Stop®	.4 (.18)
007364	with Spout Ring and Magnetic Accufuel® Safety Feature	.4 (.18)

X DEF Nozzle Spout Assemblies

MODEL NO.	DESCRIPTION	SHIPPING WEIGHT LBS (KG)
013285	with StreamShaper®	.4 (.18)
013286	with Spout Ring and Magnetic Accufuel® Safety Feature	.4 (.18)

Polymer DEF Nozzle Spout Assemblies

MODEL NO.	DESCRIPTION	SHIPPING WEIGHT LBS (KG)
013591	with StreamShaper®	.4 (.18)
013592	with Spout Ring and StreamShaper®	.4 (.18)
013593	with Spout Ring and Magnetic Accufuel® Safety Feature	.4 (.18)



WARNING: Cancer and Reproductive Harm - www.P65Warnings.ca.gov

DEF Spouts

Spout assemblies

Dimensions

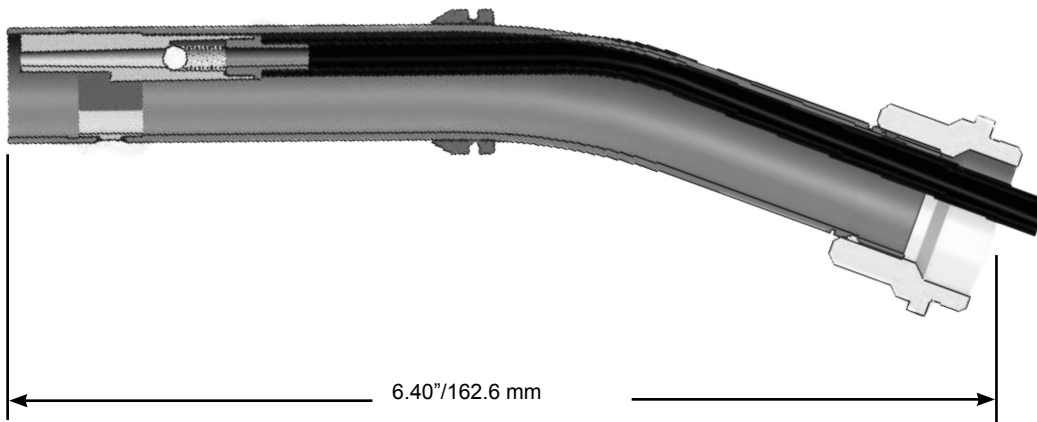
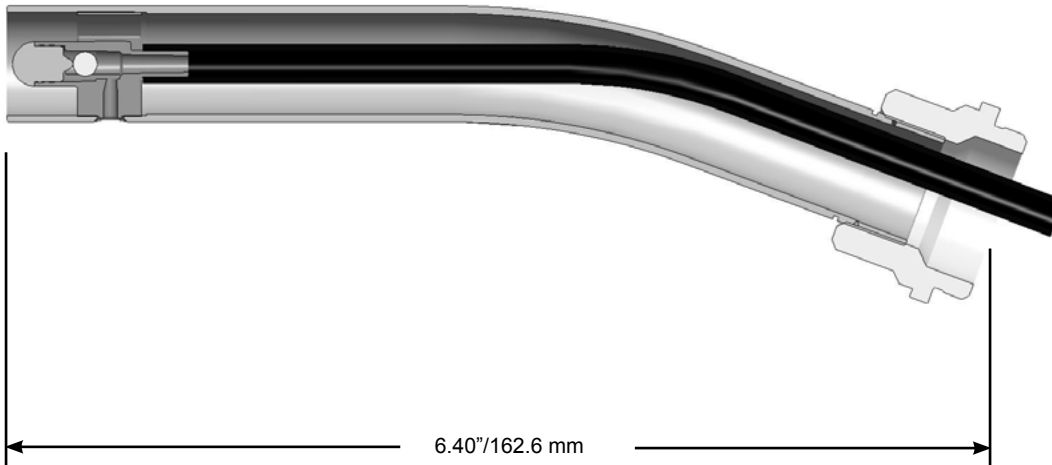
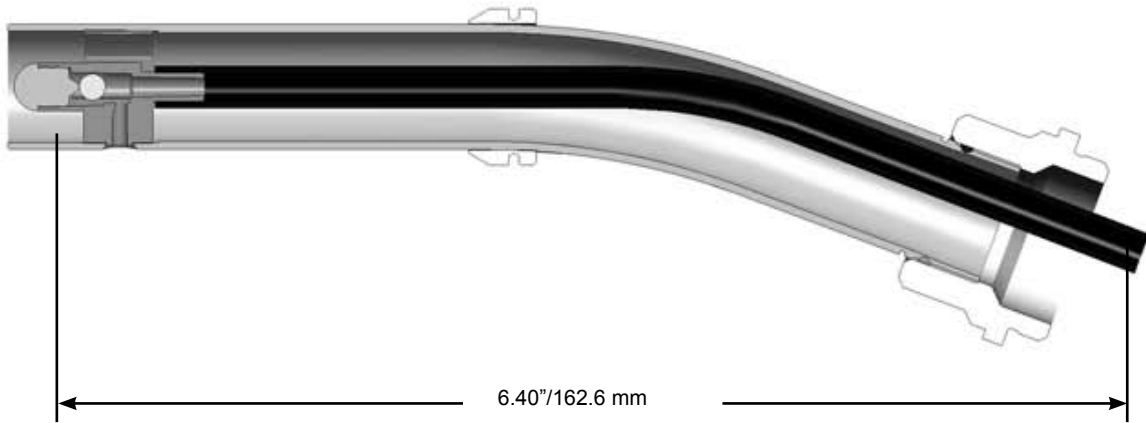

VIII, VIIS Spouts

Spout assemblies

- Aluminum Spout Bushing
- Retains spout spring
- Flow stop device
- Shuts off flow when spout is raised above horizontal
- Reduces rounding in of spout



High Flow/High Volume Spout Assemblies

MODEL NO.	DESCRIPTION	SHIPPING WEIGHT LBS (KG)
002279	VIII, VIIS Spout Assembly with Spout Bushing	.9 (.41)
003589	VIII, VIIS Long Spout Assembly without Spout Bushing	1.0 (.45)
004889	1690 High-Volume Spout Assembly without Shear Groove (USA)	.5 (.23)
005017	VIII, VIIS Spout Assembly without Spout Bushing	.9 (.41)
005042	1691 High-Volume Spout Assembly with Shear Groove (Canada)	.5 (.23)
005215	1HS, 1GS Spout Assembly	.4 (.18)
007218	VIII, VIIS Long Spout Assembly with Spout Bushing	1.0 (.45)



WARNING: Cancer and Reproductive Harm - www.P65Warnings.ca.gov

VII, VIIS Spouts

Spout assemblies

Dimensions

High Flow/High Volume Spouts

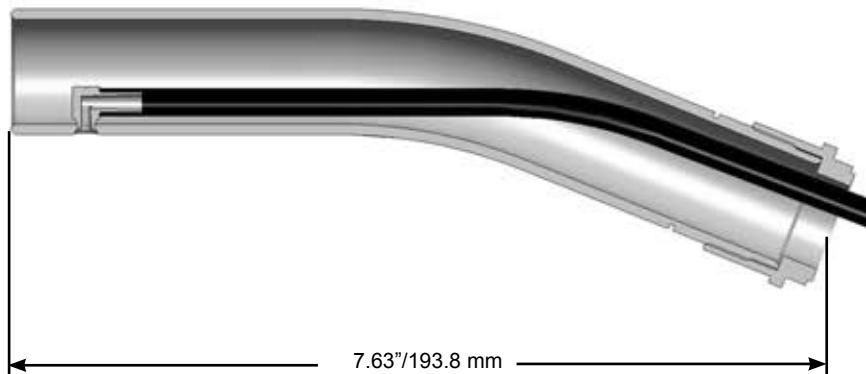
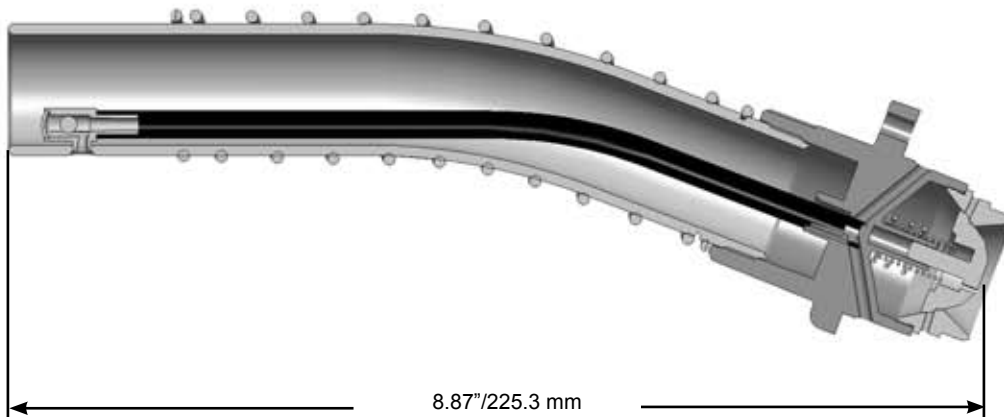
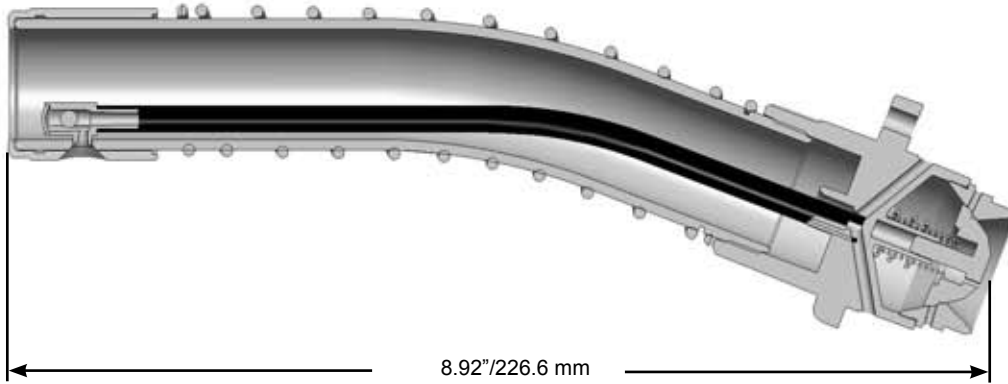

V3 & V34 Spouts

Spout assemblies

- Stainless steel spout bushing
- *Streamshaper*® reduces turbulence for straighter fuel flow and less splash back spillage.
- Keeps spout tip round



V3 Spout Kit



V34 Spout Kit

Vacuum Assist Vapor Recovery Unleaded Spout Assemblies

MODEL NO.	DESCRIPTION	SHIPPING WEIGHT LBS (KG)
004000	V34 Vapor Splash Guard (VSG) (Includes 004039 Clamp)	.1 (.05)
004039	VSG Single Use Clamp	.1 (.05)
006289	V3 Spout Assy Kit (Includes 006389 Spout Assembly and 006955 Waffle Splash Guard)	.3 (.14)
006291	V34 Spout Assy Kit (Includes 004000 VSG and 006391 Spout Assembly)	.3 (.14)
006389	V3 Spout Assembly (without Waffle Splash Guard)	.2 (.09)
006391	V34 Spout Assembly with Streamshaper®	.3 (.14)
006656	V34-006536 VSG (Includes 004039 Clamp)	.1 (.05)
006663	V34-006536 Spout Assembly Kit (Includes 006391 Spout Assembly and 006656 VSG)	.3 (.14)
008411	V34i Spout Assembly Kit with Streamshaper® (Includes 003877 O-Ring and 006511 Set Screw)	.2 (.09)
008642	V34-006200 Coaxial Spout Assembly Kit (Includes 009968 Spout Assembly and 004000 VSG)	.3 (.14)
009968	V34-006200 Coaxial Spout Assembly	.2 (.09)

Vacuum Assist Vapor Recovery Light Duty Diesel Spout Assemblies

MODEL NO.	DESCRIPTION	SHIPPING WEIGHT LBS (KG)
006261	V34C Spout Assembly Kit (Includes 004000 Vsg)	.4 (.18)
006361	V34 Spout Assembly Kit (Includes 004039 Clamp)	.3 (.14)



 WARNING: Cancer and Reproductive Harm - www.P65Warnings.ca.gov

V3 & V34 Spouts

Spout assemblies

Dimensions

Vacuum Assist Vapor Recovery

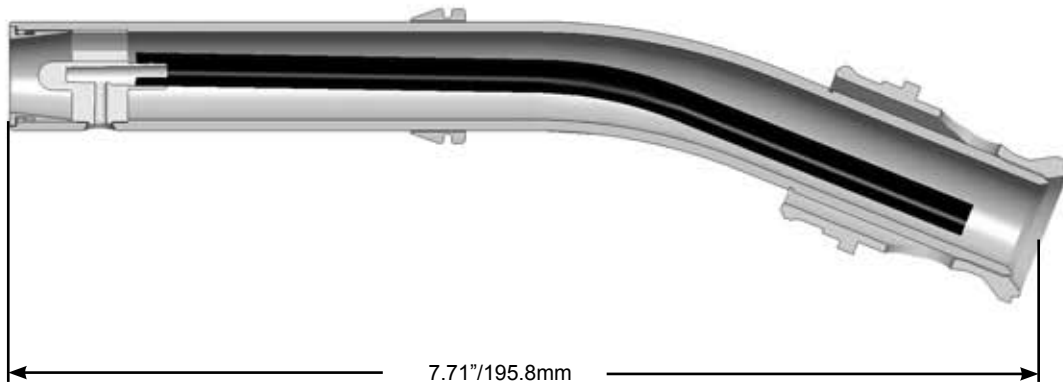

E85 Spouts

Spout assemblies

- Nickel plated aluminum spout
- *Streamshaper*[®]
- Stainless Steel Spout Bushing
- E85 compatible
- Keeps spout tip round
- Reduces turbulence for straighter fuel flow and less splashback spillage.



Ethanol Spout Assemblies

MODEL NO.	DESCRIPTION	SHIPPING WEIGHT LBS (KG)
006207	X, XS [®] E85 Spout Assembly with Streamshaper [®]	.4 (.18)



WARNING: Cancer and Reproductive Harm - www.P65Warnings.ca.gov

E85 Spouts

Spout assemblies

Dimensions

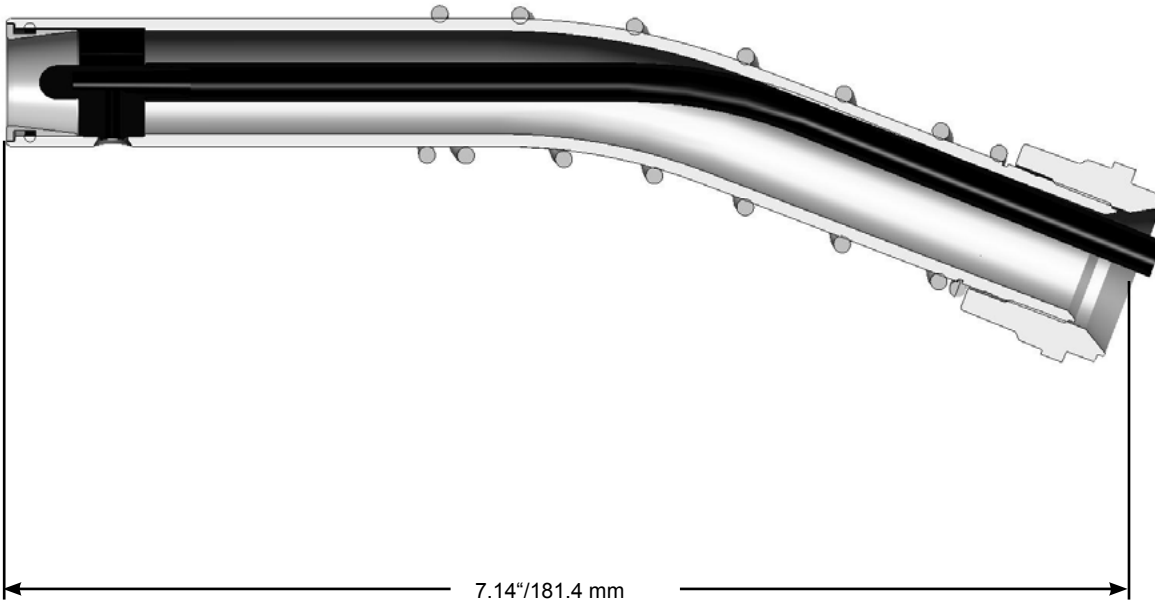



GENERAL FUELING PRODUCTS

PV Vents

Model 008060 has three (3) separate valves that address pressure/vacuum conditions in underground storage tanks (UST) and above ground storage tanks (AST).

- Husky pressure/vacuum (P/V) vents incorporate three (3) separate valves to control over-pressure and vacuum conditions that arise in storage tanks. The three (3) valve system provides the necessary protection and durability needed in UST and AST vent caps.
- The vacuum valve is diaphragm operated and provides ten (10) times more sealing force than gravity devices. It constantly opens at 6" - 8" of water column (WC)/2 - 2.5 KPa vacuum.
- The first over-pressure valve is diaphragm operated, giving ten (10) times more sealing force than gravity devices. It opens at 8" - 12" WC/.75 - 1.5 KPa pressure.
- The safety over-pressure valve is designed to handle high pressure/high flow conditions. This valve will vent up to 7900 SCFH at 2 psi/.14 bar.
- Threaded vent cap that is easily installed by using the cast-on hex nut which allows tightening without having to go between vent pipes
- Not for use in California/ EVR applications
- Constructed from materials 100% compatible with B0-B20 and E0-E85

Pressure/Vacuum Vents

MODEL NO.	DESCRIPTION	SHIPPING WEIGHT LBS (KG)
008060	2" / 51 mm Thread-On Pressure / Vacuum Vent Cap	1.2 (.54)

Construction

Body	Aluminum
Screen	40 Mesh Stainless Steel
Set Screws	Stainless Steel
Deflector	Aluminum



This component was tested to and met the following criteria:

PRES. 8-12 IN. W.C.

VAC. 6-8 IN. W.C.

.05 CFH @ +2 IN. W.C.

.21 CFH @ -4 IN. W.C.

PV Vents

Model 008060 has three (3) separate valves that address pressure/vacuum conditions in underground storage tanks (UST) and above ground storage tanks (AST).

Dimensions and System Options

Adapter

MODEL NO.	DESCRIPTION
005041	3 in / 76 mm Thread to 2 in / 51 mm Thread Pipe Adapter

Testing Equipment

MODEL NO.	DESCRIPTION
005426	Pressure / Vacuum Vent Test Adapter

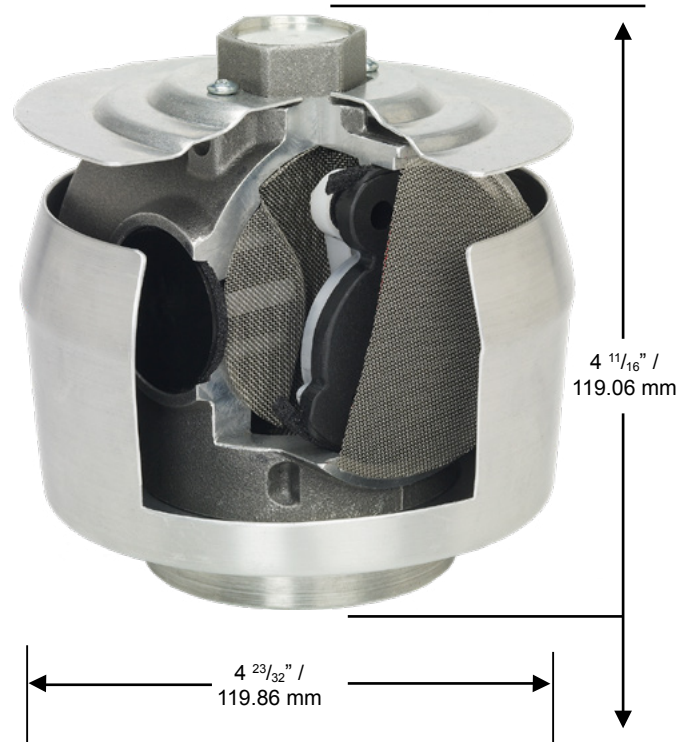

Model 008060 has three (3) separate valves that address pressure/vacuum conditions in underground storage tanks (UST) and above ground storage tanks (AST).

Model 004620 and 004885

- The three (3) valve system provides the necessary protection and durability needed in UST and AST vent caps.
- The vacuum valve is diaphragm operated and provides ten (10) times more sealing force than gravity devices. It consistently opens at 6" - 10" of water column (WC)/1.5 - 2.5 KPa vacuum.
- The first over-pressure valve is diaphragm operated, giving ten (10) times more sealing force than gravity devices. It opens at 2.5" - 6" WC/.63 - 1.5 KPa pressure.
- Not for use in California/EVR applications
- Model 004885 is certified to less than 1/3 of the CARB EVR Standard CP-201 which allows installation of three (3) P/V Vents maximum. This reduces installation time by not having to manifold the vent pipes together.
- Model 004885 is a threaded vent cap that is easily installed by using the caston hex nut which allows tightening without having to go between vent pipes.
- Model 004620 is a slip-on vent cap with a main pliable seal that seals to the vent stack and provides leakproof protection because the seal is at the end of the vent stack, not on the threads.

- Model 004620 uses four (4) stainless steel set screws to grip the vent stack preventing any loosening of the seal.
- Constructed from materials 100% compatible with B0-B20 and E0-E85

Model 005885*

- Has an internal screen to protect the pressure plate in the event of a bad bulk drop
- The safety over-pressure valve is designed to handle high pressure/high flow conditions. This valve will vent up to 7900 SCFH at 2 psi/.14 bar.
- Certified to less than 1/3 of the CARB EVR Standard CP-201 which allows installation of three (3) P/V vents maximum. This reduces installation time by not having to manifold the vent pipes together.
- Has a threaded vent cap that is easily installed by using the cast-on hex nut. This also allows tightening without having to go between vent pipes.
- Constructed from materials 100% compatible with B0-B20 and E0-E85

Pressure/Vacuum Vents

MODEL NO.	DESCRIPTION	SHIPPING WEIGHT LBS (KG)
004620	2 in / 51 mm Slip-On Pressure / Vacuum Vent Cap	1.2 (.54)
004885	2 in / 51 mm Thread-On Pressure / Vacuum Vent Cap	1.2 (.54)
005885*	2 in / 51 mm Thread-On Pressure / Vacuum Vent Cap with internal screen	1.2 (.54)

Construction

Body	Aluminum
Screen	40 Mesh Stainless Steel
Internal Screen	40 Mesh Stainless Steel (005885 only)
Set Screws	Stainless Steel
Deflector	Aluminum



This component was tested to and met the following criteria:

PRES. 2.5-6 IN. W.C.
VAC. 6-10 IN. W.C.
.05 CFH @ +2 IN. W.C.
.21 CFH @ -4 IN. W.C.



CALIFORNIA AIR RESOURCES BOARD

PV Vents

Model 008060 has three (3) separate valves that address pressure/vacuum conditions in underground storage tanks (UST) and above ground storage tanks (AST).

Dimensions and System Options

Adapter

MODEL NO.	DESCRIPTION
005041	3 in / 76 mm Thread to 2 in / 51 mm Thread Pipe Adapter

Testing Equipment

MODEL NO.	DESCRIPTION
005426	Pressure / Vacuum Vent Test Adapter

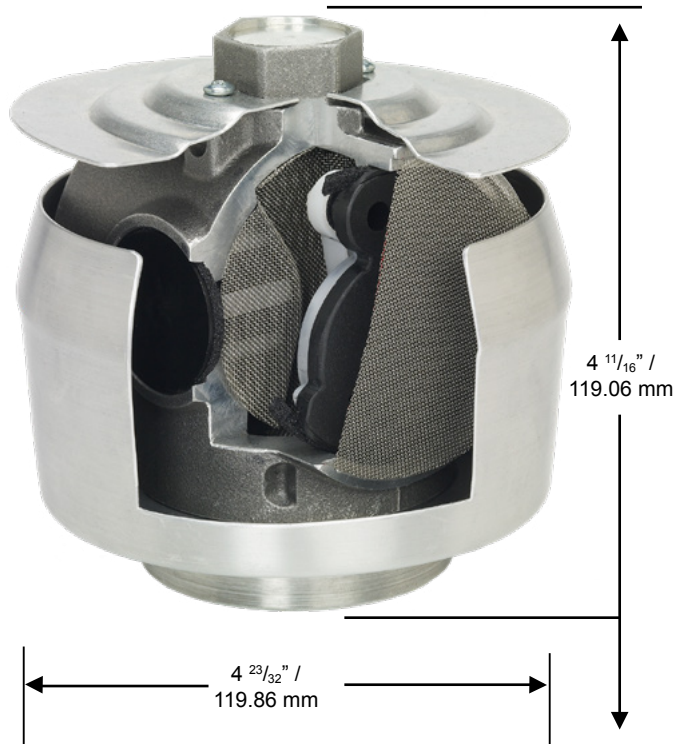



GENERAL FUELING PRODUCTS

Testing & Maintenance

Nozzle Service Kit

For Conventional, Balance, or Vacuum Assist Systems

- Nozzle Service Device (NSD) can be used with all brands/styles of retail nozzles.
- NSD provides easier removal and installation of nozzles - keeps nozzles off the ground.
- Safe-T-Break® Drain Cup can be used with all brands of breakaways - even non-reconnectable versions.
- Safe-T-Break® Drain Cup allows for pressure relief making reconnecting easier.
- Fuel Filter Cup can be used on all brands/styles of automotive and diesel dispenser fuel filters.
- Provides safe collection of fuel when replacing nozzles, Safe-T-Breaks® and fuel filters
- Allows product maintenance without getting fuel directly on hands/skin
- NSD, Safe-T-Break® Drain Cup, Fuel Filter Cup, wrench and pliers all fit inside the service pail for easy transportation

Nozzle Service Kit

MODEL NO.	DESCRIPTION	SHIPPING WEIGHT LBS (KG)
007089	Nozzle Service Kit (includes part 006662 NSD, 007000 Safe-T-Break® Drain Cup, 007004, Fuel Filter Cup, 007086 Service Pail, 007088 NSD Pliers, 007332 Shear Valve Wrench and 007098 Fuel Filter Tool)	9.5 (4.3)

Basic Nozzle Service Kit

MODEL NO.	DESCRIPTION	SHIPPING WEIGHT LBS (KG)
007262	Basic Nozzle Service Kit (includes part 006662 NSD, 007000 Safe-T-Break® Drain Cup, 007004, Fuel Filter Cup and 007086 Service Pail)	9.0 (4.0)

Deluxe Nozzle Service Kit

MODEL NO.	DESCRIPTION	SHIPPING WEIGHT LBS (KG)
007263	Deluxe Nozzle Service Kit (includes part 006662 NSD, 007000 Safe-T-Break® Drain Cup, 007004, Fuel Filter Cup, 007086 Service Pail, 007332 Shear Valve Wrench, 007348 Deluxe Service Pliers and 007349 Deluxe Fuel Filter Pliers)	9.5 (4.3)

Construction

Service Pail	Steel
Nozzle Service Device (NSD)	Polypropylene
Safe-T-Break® Drain Cup	Polypropylene
Fuel Filter Cup	Plastisol



⚠ WARNING: Cancer and Reproductive Harm - www.P65Warnings.ca.gov

Nozzle Service Kit

For Conventional, Balance, or Vacuum Assist Systems

Dimensions and System Options

Nozzle Service Kit Parts

MODEL NO.	DESCRIPTION
006662	Nozzle Service Device (NSD)
007000	Safe-T-Break® Drain Cup
007004*	Fuel Filter Cup
007086	Service Pail
007088	NSD 12" Pliers
007098	Fuel Filter Tool (Wrench)
007099	Fuel Filter Service Kit (includes part 007004 Fuel Filter Cup and 007098 Fuel Filter Tool)
007332	Shear Valve Wrench
007348	Deluxe Service Pliers
007349	Deluxe Fuel Filter Pliers
007350	Deluxe Service Tool Kit (includes 007332 Shear Valve Wrench, 007348 Service Pliers, and 007349 Fuel Filter Pliers)
008071	Fuel Filter Cap with 5" Base



Part No. 007086



Part No. 007000



Part No. 007004

Guard Color Chart

COLOR	SUFFIX	COLOR	SUFFIX	COLOR <i>CUSTOM</i>	SUFFIX
Blue	-01	Gold	-08	Amoco Blue	-07 <i>CUSTOM</i>
Red	-02	Silver	-09	Apple Green	-18 <i>CUSTOM</i>
Green	-03	BP Green	-16	Purple	-19 <i>CUSTOM</i>
Black	-04	M Blue	-21	Pink	-20 <i>CUSTOM</i>
Yellow	-05	Orange	-39	BPS Green	-22 <i>CUSTOM</i>
White	-06				

Scuff Guards are to be ordered with the corresponding guard color option added to the model number. Example: If BLUE guards are desired, add guard color option -01 to the model number (159504-01). For custom colors, a minimum order of 4,000 guards will be required.



Part No. 006662

HCA Hose Conversion Adaptor

For Conventional, Balance, or Vacuum Assist Systems

- Easy conversion of vapor recovery dispenser manifold to accept conventional hose configurations

Specifications

- 1 piece machined aluminum fittings
- Fluorocarbon o-rings.

Advantages

- Simple installation



WARNING: Cancer and Reproductive Harm - www.P65Warnings.ca.gov

HCA Hose Conversion Adaptor

For Conventional, Balance, or Vacuum Assist Systems

Dimensions and System Options

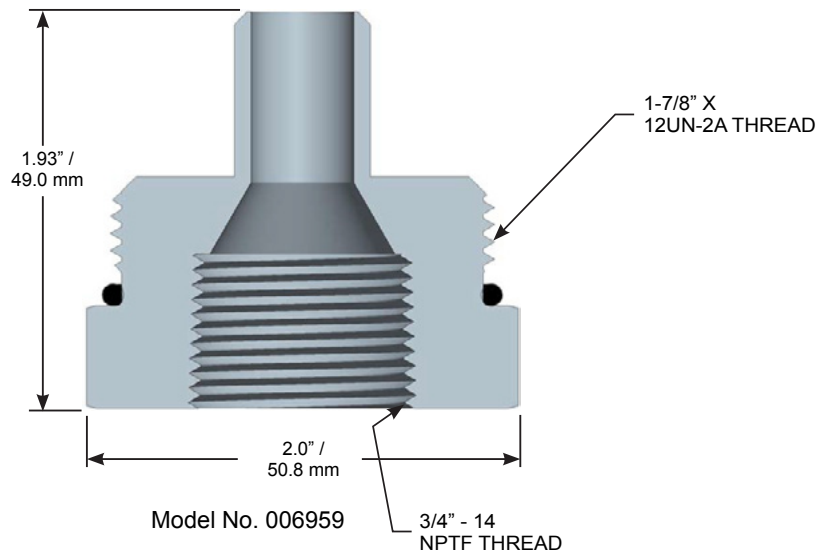
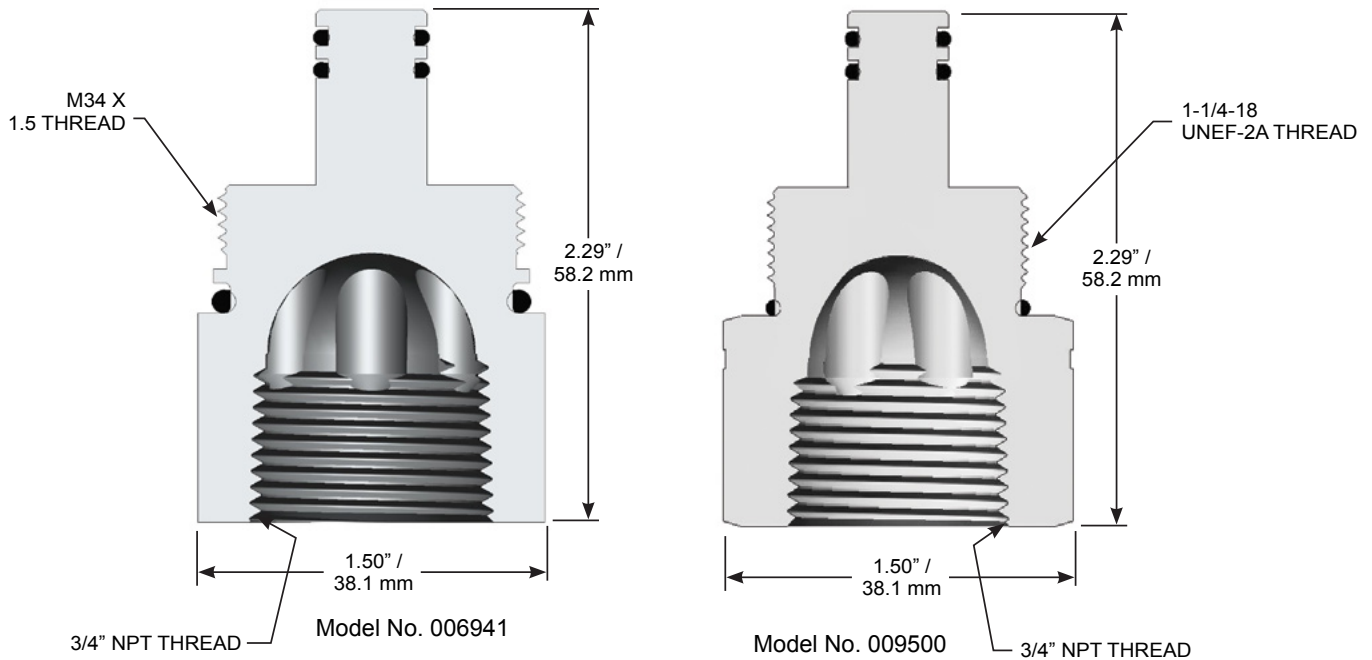

Mobile Fill Neck Device

For Conventional, Balance, or Vacuum Assist Systems

- Optimized for assessing nozzle performance by simulating a real-time tank fueling environment
- Equipped with a ball valve for easy drainage and cleanup
- Engineered to have a robust design that ensures longevity
- Folds into a compact size for easy transport and storage
- Built with the leading fill neck in the industry
- Anodized to prevent corrosion
- Unique design aids service technicians with diagnosis of damaged or worn nozzles in the field

Mobile Fill Neck

MODEL NO.	DESCRIPTION	SHIPPING WEIGHT LBS (KG)
014381	Unleaded Mobile Fill Neck Device	

Construction

Anodized Aluminum, Stainless Steel, and Brass



**Bucket and hanging hardware not included*



 WARNING: Cancer and Reproductive Harm - www.P65Warnings.ca.gov

Mobile Fill Neck Device

For Conventional, Balance, or Vacuum Assist Systems

Dimensions and System Options

Mobile Fill Neck Device Accessories

MODEL NO.	DESCRIPTION
006662	Nozzle Service Device (NSD)
007000	Safe-T-Break® Drain Cup
007004*	Fuel Filter Cup
007086	Service Pail
007088	NSD 12" Pliers
007089	Nozzle Service Kit (includes part 006662 NSD, 007000 Safe-T-Break® Drain Cup, 007004, Fuel Filter Cup, 007086 Service Pail, 007088 NSD Pliers, 007332 Shear Valve Wrench and 007098 Fuel Filter Tool)
007098	Fuel Filter Tool (Wrench)
007099	Fuel Filter Service Kit (includes part 007004 Fuel Filter Cup and 007098 Fuel Filter Tool)
007262	Basic Nozzle Service Kit (includes part 006662 NSD, 007000 Safe-T-Break® Drain Cup, 007004 Fuel Filter Cup and 007086 Service Pail)
007263	Deluxe Nozzle Service Kit (includes part 006662 NSD, 007000 Safe-T-Break® Drain Cup, 007004 Fuel Filter Cup, 007086 Service Pail, 007332 Shear Valve Wrench, 007348 Deluxe Service Pliers and 007349 Deluxe Fuel Filter Pliers)
007332	Shear Valve Wrench
007348	Deluxe Service Pliers
007349	Deluxe Fuel Filter Pliers
007350	Deluxe Service Tool Kit (includes 007332 Shear Valve Wrench, 007348 Service Pliers, and 007349 Fuel Filter Pliers)
008071	Fuel Filter Cup with 5" Base



Part No. 007086



Part No. 007000



Part No. 007004*



Part No. 006662

Guard Color Chart

COLOR	SUFFIX	COLOR	SUFFIX	COLOR <i>CUSTOM</i>	SUFFIX
Blue	-01	Gold	-08	Amoco Blue	-07 <i>CUSTOM</i>
Red	-02	Silver	-09	Apple Green	-18 <i>CUSTOM</i>
Green	-03	BP Green	-16	Purple	-19 <i>CUSTOM</i>
Black	-04	M Blue	-21	Pink	-20 <i>CUSTOM</i>
Yellow	-05	Orange	-39	BPS Green	-22 <i>CUSTOM</i>
White	-06				

Scuff Guards are to be ordered with the corresponding guard color option added to the model number. Example: If BLUE guards are desired, add guard color option -01 to the model number (159504-01). For custom colors, a minimum order of 4,000 guards will be required.

Full Filter & Drain Cups

Safe and Clean filter removal.

- 007004, 008071, 016506, 016664, & 016642 safely holds oils, fuel (gasoline, diesel, biofuels), brake fluid, antifreeze and other hazardous fluids.
- Pliable, non-slip plastisol material conforms for secure grip including within small, oddly shaped places.
- Allows filter maintenance without getting fuel or oil directly on the skin
- Filter Cups can be used on all brands and styles of fuel dispenser and vehicle fuel/oil filters.
- Great for storing loose nuts, bolts, screws, drain plugs, and other items during service
- 007000 Safe-T-Break Drain Cup
- Safe-T-Break Drain Cup allows for pressure relief making reconnecting easier.
- Safe-T-Break Drain Cup safely collects fuel to avoid spills when changing or reconnecting breakaways.
- Safe-T-Break Drain Cup can be used with all brands of breakaways- even non-reconnectable versions.

Filter Cups

MODEL NO.	DESCRIPTION	SHIPPING WEIGHT LBS (KG)
007004	Filter Cup, 5.8"H x 3.60" Base ID	.53 (.24)
008071	Filter Cup, 5.85"H x 4.98" Base ID	.71 (.32)
016506	Filter Cup, 7.5"H x 4.98" Base ID	.88 (.40)
016664	Filter Cup, 7.5"H x 3.85" Base ID	.70 (.32)
016642	Filter Cup, 3.85"H x 2.88" Base ID	.21 (.09)

Safe-T-Break Drain Cup

MODEL NO.	DESCRIPTION	SHIPPING WEIGHT LBS (KG)
007000	Safe-T-Break Drain Cup	.13 (.06)



WARNING: Cancer and Reproductive Harm - www.P65Warnings.ca.gov

Full Filter & Drain Cups

Safe and Clean filter removal.

Dimensions

MODEL NO. 008071



MODEL NO. 007004



MODEL NO. 016642



MODEL NO. 016506



MODEL NO. 016664



MODEL NO. 007000

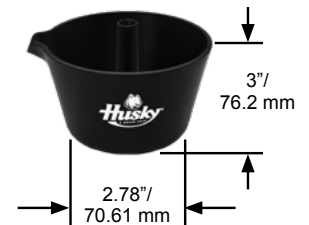

Guard Color Chart

COLOR	SUFFIX	COLOR	SUFFIX	COLOR	SUFFIX	COLOR	SUFFIX	COLOR	SUFFIX	COLOR	SUFFIX
Blue	-01	Black	-04	Gold	-08	M Blue	-21	Apple Green	-18 <i>CUSTOM</i>	BPS Green	-22 <i>CUSTOM</i>
Red	-02	Yellow	-05	Silver	-09	Orange	-39	Purple	-19 <i>CUSTOM</i>		
Green	-03	White	-06	BP Green	-16	Amoco Blue	-07 <i>CUSTOM</i>	Pink	-20 <i>CUSTOM</i>		

Scuff Guards are to be ordered with the corresponding guard color option added to the model number. Example: If BLUE guards are desired, add guard color option -01 to the model number (159504-01). For custom colors, a minimum order of 4,000 guards will be required. Custom logos for private branding are available. Email sales@husky.com for more information.



GENERAL FUELING PRODUCTS

Flo-Equalizers®

Flo-Equalizer®

Husky Flo-Equalizers® limit fuel flow to a maximum 10 gpm / 37.9 Lpm to comply with Comprehensive Environmental Response, Compensation, and Liability Act.

- All Husky Flo-Equalizers® are pressure compensating and allow full advantage of high capacity pumps.
- Low pressure loss at flows less than 10 gpm/37.9 Lpm

Model 004490

- For conventional systems
- Installs in-line within the fuel line
- Comes standard with pipe nipple for easy installation

Model 005827

- For balance vapor recovery systems
- Installs directly into the dispenser outlet casting

Model 005837

- For vacuum assist vapor recovery systems
- Installs directly into the dispenser outlet casting

Model 007490

- For conventional nozzles with 3/4"/19 mm inlet
- Installs into nozzle inlet

Flo-Equalizer®

MODEL NO.	DESCRIPTION	SHIPPING WEIGHT LBS (KG)
004490	3/4" F x 3/4" F NPT threads	.37 (0.16)
005827	1 1/8" x 12 threads	.43 (0.19)
005837	M34 x 1.5 threads	.37 (0.16)
007490	Internal use only	.02 (0.01)

Construction

Body	004490, 005827 and 005837: Aluminum 007490: Plastic
Seals	004490 and 700490: N/A 005827 and 005837: Fluorocarbon



Model 004490



Model 005827

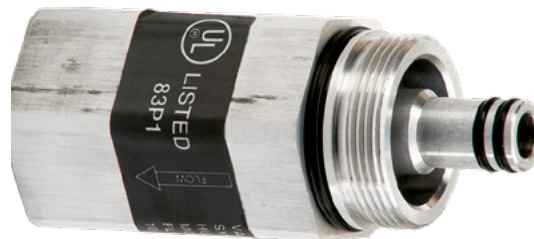

Model 005837



Model 007490



WARNING: Cancer and Reproductive Harm - www.P65Warnings.ca.gov

Flo-Equalizer®

For nozzles and Safe-T-Breaks® Husky Flo-Equalizers® limit fuel flow to a maximum 10 gpm / 37.9 Lpm to comply with Comprehensive Environmental Response, Compensation, and Liability Act.

Dimensions and System Options

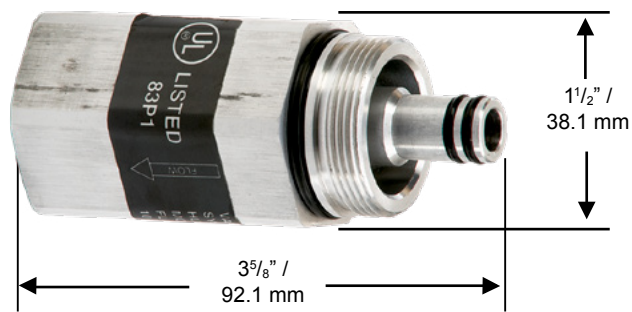
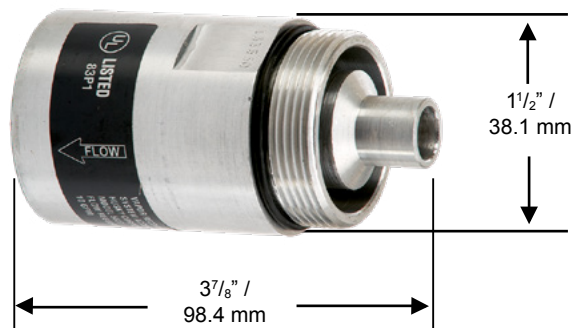



GENERAL FUELING PRODUCTS

DEF Adaptors

DEF Adaptors

Diesel Exhaust Fueling Adaptors

- 007214, 007285, 007356, 008413, 010579, 010675, 011477 and 012872 adaptors have stainless steel construction.
- 010227, 010549, 010551 and 010553 adaptors have polymer construction.
- 007214, 007285, 007356 and 008413 adaptors are UL recognized components and certified for DEF.

Diesel Exhaust Adaptors

MODEL NO.	DESCRIPTION	SHIPPING WEIGHT LBS (KG)
007214	Hose Barb 3/4" ID Hose x 3/4" BSPP with Seal Kit	.22 (.10)
007285	1" M x 1" M BSPP Straight Adaptor	.29 (.13)
007356	1" M BSPP x M M34 Straight Adaptor	.30 (.13)
008413	Hose Barb 3/4" ID Hose x 1" BSPP with Seal Kit	.29 (.13)
010227	1" F BSPP Adaptor	.20 (.10)
010549	1" F BSPP x 1" NPT Adaptor	.20 (.10)
010551	1" F BSPP x 3/4" NPT Adaptor	.20 (.10)
010553	1" F BSPP x 3/4" BSP Adaptor	.20 (.10)
010579	1" F BSPP x 3/4" Hose Barb Adaptor	.20 (.10)
010675	1" F x 1" F BSPP Straight Adaptor	.20 (.10)
011477	1" M BSPP x 3/4" F NPT Straight Adaptor	.22 (.10)
012872	1" M BSPP x 3/4" F BSPP Straight Adaptor	.22 (.10)



Model 007214



Model 008413



Model 007356



Model 007285



 WARNING: Cancer and Reproductive Harm - www.P65Warnings.ca.gov

DEF Adaptors

Diesel Exhaust Fueling Adaptors.

Dimensions and System Options

Accessories

MODEL NO.	DESCRIPTION
007406	3/4" DEF Seal Kit
007407	1" DEF Seal Kit

Model 007214

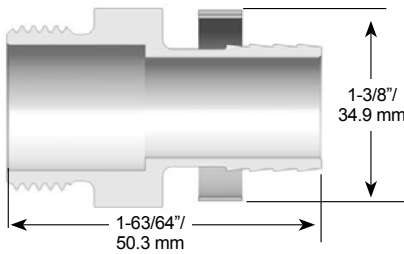

Model 007285

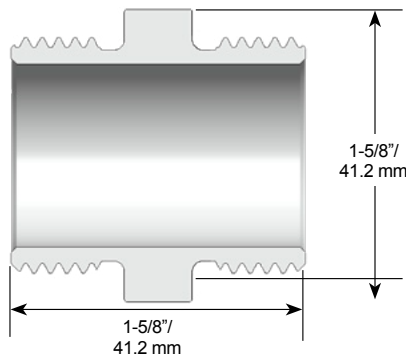

Model 007356

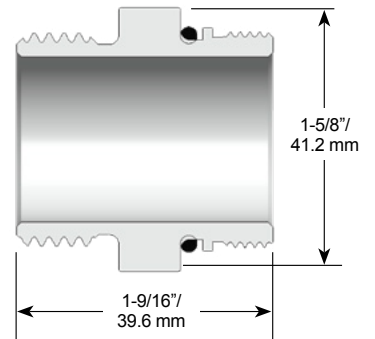

Model 008413

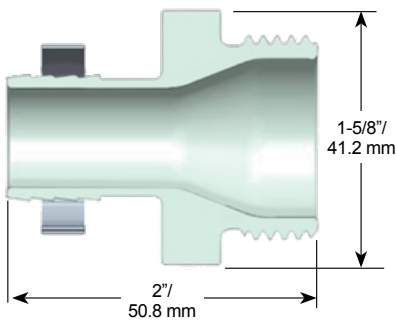

Model 010579

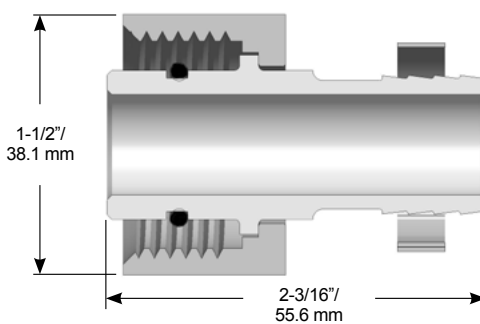

Model 010675

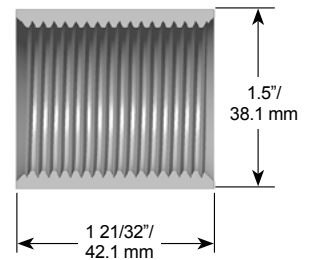

Model 010227

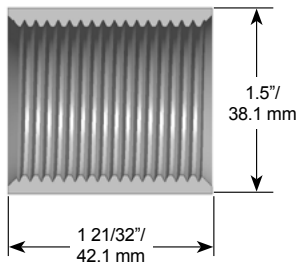

Model 010549

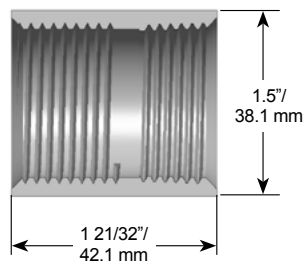

Model 010551

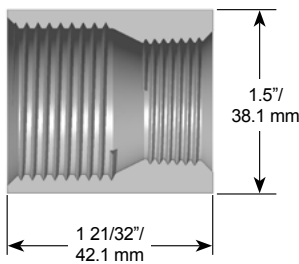

Model 010553

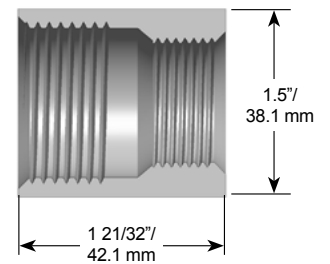

Model 011477 & 012872

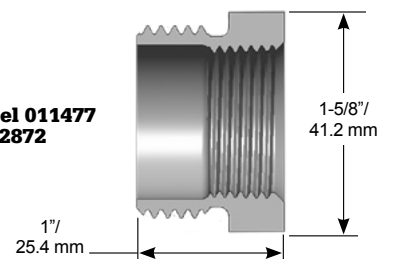

Rev 6 1/20



GENERAL FUELING PRODUCTS

Hoses

EagleFlex® Hardwall

Premium Hardwall Gasoline Pump Hose

- Recommended anywhere a hardwall hose is required
- Resists kinking and eliminates meter creep
- Recommended for all gasoline and gasoline/Ethanol blends at Ethanol levels designated as “gasohol” (E15 maximum or less), diesel fuel and diesel fuel/biodiesel blends with nominal biodiesel concentrations up to 20% (B0-B20), kerosene and fuel oil (heating oil), leaded and unleaded gasoline
- Improves ozone and abrasion resistance while providing increased life
- Improves draping and handling characteristics
- Will not mark or scratch vehicle finishes
- Hose material is private branded and UL Listed to UL 330 and CAN/ULC-S612-99
- Designed for durability, flexibility, and easy handling
- All curb pump hose assemblies are 100% pressure tested, inspected for electrical continuity and sample pull tested.
- Highly resistant to cuts, abrasions, sun and weather

(See page two for coupling descriptions)

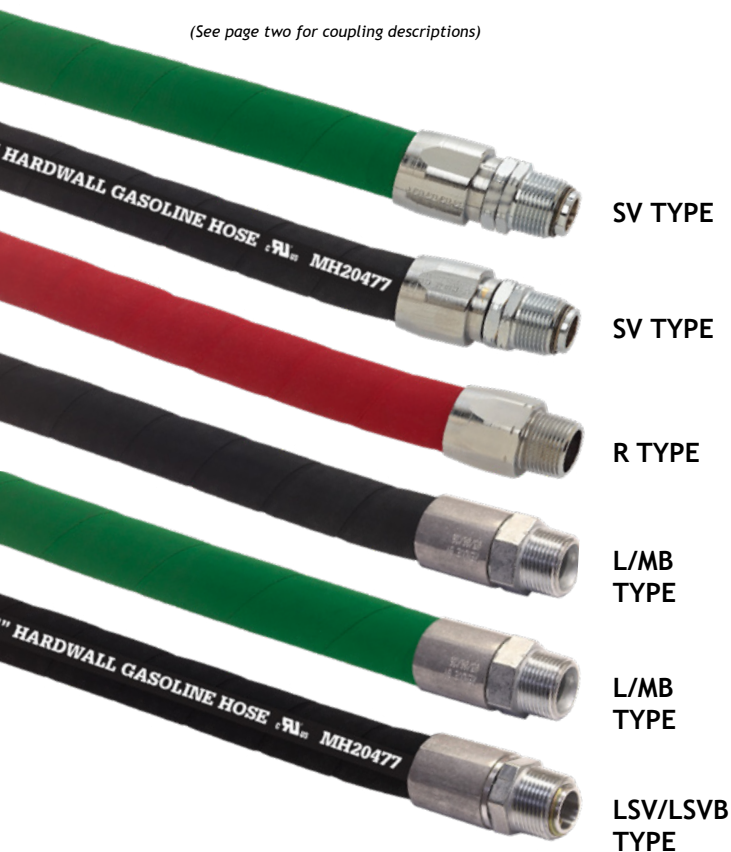

Hardwall Hoses

MODEL NO.	DESCRIPTION	SHIPPING WEIGHT LBS (KG)
5/8" HOSES		
CP10HW09	5/8" Hardwall 9' Assembly Hose	3.5 (1.6)
3/4" HOSES		
CP12HWG08	3/4" Green Hardwall 8' Assembly Hose	3.8 (1.7)
CP12HWG09	3/4" Green Hardwall 9' Assembly Hose	4.2 (1.9)
CP12HWG10	3/4" Green Hardwall 10' Assembly Hose	4.7 (2.1)
CP12HWG12SV	3/4" Green Hardwall 12' Assembly Hose Swivel	5.6 (2.5)
CP12HW09	3/4" Hardwall 9' Assembly Hose	4.2 (1.9)
CP12HW09.5	3/4" Hardwall 9.5' Assembly Hose	4.5 (2.0)
CP12HW09SV	3/4" Hardwall 9' Assembly Hose Swivel	4.2 (1.9)
CP12HW12	3/4" Hardwall 12' Assembly Hose	5.6 (2.5)
CP12HW14	3/4" Hardwall 14' Assembly Hose	6.6 (3.0)
CP12HW17	3/4" Hardwall 17' Assembly Hose	8.0 (3.6)
CP12HW01L	3/4" Hardwall 14' Assembly Hose	6.6 (3.0)
CP12HWR01L	3/4" Hardwall 14' Assembly Hose	6.6 (3.0)
CP12HW01LSV	3/4" Hardwall 14' Assembly Hose	6.6 (3.0)

1" HOSES

CP16HW01	1" Hardwall 1' Assembly Hose	0.64 (0.95)
CP16HW06	1" Hardwall 6' Assembly Hose	3.8 (1.7)
CP16HW10	1" Hardwall 10' Assembly Hose	6.4 (2.9)
CP16HW10X	1" Hardwall 10' Assembly Hose Bulk	6.4 (2.9)
CP16HW15	1" Hardwall 15' Assembly Hose	9.6 (4.4)
CP16HW15X	1" Hardwall 15' Assembly Hose Bulk	9.6 (4.4)
CP16HW17	1" Hardwall 17' Assembly Hose	10.9 (4.9)
CP16HW20X	1" Hardwall 20' Assembly Hose Bulk	12.8 (5.8)

Construction

Tube	Black Nitrile
Cover	Black CPE (chlorinated polyethylene), wrap impression
Reinforcement	Multiple textile braids with dual static wire helix
Temperature Range	-40° F to +180° F (-40° C to +82° C)
Body	3/4" Green Hardwall Available



WARNING: Cancer and Reproductive Harm - www.P65Warnings.ca.gov

EagleFlex® Hardwall

Premium Hardwall Gasoline Pump Hose

Dimensions and System Options

Available in these Sizes

Size	ID		NOM OD		MAX WP		WEIGHT	
	MM	IN	MM	IN	PSI	MPA	LB/FT	KG/M
5/8"	16	1.03	26	1.03	150	1.03	0.39	0.58
3/4"	19	1.17	30	1.03	150	1.03	0.47	0.70
1"	25	1.45	37	1.03	150	1.03	0.64	0.95

Couplings

Permanent internally expanded fixed chrome plated brass or external crimp zinc (L type).

Reattachable fixed and Reattachable swivel 3/4" and 1" male NPT. U L does not recognize field installation of reattachable fittings.



EagleFlex[®] Softwall

Softwall Gasoline Pump Hose

- A lightweight, flexible hose for use when a hardwall hose is inappropriate
- Recommended for all gasoline and gasoline/Ethanol blends at Ethanol levels designated as “gasohol” (E15 maximum or less), diesel fuel and diesel fuel/biodiesel blends with nominal biodiesel concentrations up to 20% (B0-B20), kerosene and fuel oil (heating oil), leaded and unleaded gasoline
- Excellent strength without sacrificing flexibility.
- Highly resistant to cuts, abrasions, sun and weather
- Smooth cover will not mark or scratch vehicle finishes.
- All curb pump hose assemblies are 100% pressure tested, inspected for electrical continuity and sample pull tested.



Softwall Hoses

MODEL NO.	DESCRIPTION	SHIPPING WEIGHT LBS (KG)
3/4" HOSES		
CP12SW09	3/4" Softwall 9' Assembly Hose	3.1 (1.4)
CP12SW10	3/4" Softwall 10' Assembly Hose	3.4 (1.5)
CP12SW10X	3/4" Softwall 10' Assembly Hose Bulk	3.4 (1.5)
CP12SW12	3/4" Softwall 12' Assembly Hose	4.1 (1.9)
CP12SW14	3/4" Softwall 14' Assembly Hose	4.8 (2.2)
CP12SW14X	3/4" Softwall 14' Assembly Hose Bulk	4.8 (2.2)
CP12SW17	3/4" Softwall 17' Assembly Hose	5.8 (2.6)
CP12SW20	3/4" Softwall 20' Assembly Hose	6.8 (3.1)
CP12SW30	3/4" Softwall 30' Assembly Hose	10.2 (4.6)
CP12SW50	3/4" Softwall 50' Assembly Hose	17.0 (7.7)
CP12SW9.5	3/4" Softwall 9.5' Assembly Hose	3.2 (1.5)
1" HOSES		
CP16SW10	1" Softwall 10' Assembly Hose	4.7 (2.1)
CP16SW12	1" Softwall 12' Assembly Hose	5.6 (2.5)
CP16SW14	1" Softwall 14' Assembly Hose	6.6 (3.0)
CP16SW14X	1" Softwall 14' Assembly Hose Bulk	6.6 (3.0)
CP16SW17	1" Softwall 17' Assembly Hose	8.0 (3.6)
CP16SW20	1" Softwall 20' Assembly Hose	9.4 (4.3)
CP16SW20X	1" Softwall 20' Assembly Hose Bulk	9.4 (4.3)
CP16SW60	1" Softwall 60' Assembly Hose	28.2 (12.8)

Construction

Tube	Black Nitrile
Cover	Black CPE (chlorinated polyethylene), smooth finish
Reinforcement	Multiple textile braids static wire
Temperature Range	-40° F to +180° F (-40° C to +82° C)



WARNING: Cancer and Reproductive Harm - www.P65Warnings.ca.gov

EagleFlex® Softwall

Softwall Gasoline Pump Hose

Dimensions and System Options

Available in these Sizes

ID size	NOM OD		MAX WP		WEIGHT		
	MM	IN	PSI	MPA	LB/FT	KG/M	
3/4"	19	1.10	28	150	1.03	0.34	0.51
1"	25	1.39	35	150	1.03	0.47	0.63

Couplings

Permanent internally expanded fixed chrome plated brass or external crimp zinc (L type).

Reattachable fixed and Reattachable swivel 3/4" and 1" male NPT. U L does not recognize field installation of reattachable fittings.



EagleFlex[®] Wirebraid

Premium Hardwall Gasoline Pump Hose

- Recommended anywhere a hardwall or softwall hose is inappropriate
- Recommended for all gasoline and gasoline/Ethanol blends at Ethanol levels designated as "gasohol" (E15 maximum or less), diesel fuel and diesel fuel/biodiesel blends with nominal biodiesel concentrations up to 20% (B0-B20), kerosene and fuel oil (heating oil), leaded and unleaded gasoline
- Resistant to crushing and stands up to run-over
- Highly resistant to cuts,
- Flexibility of a softwall, durability of a hardwall
- Assures accurate readings at the pump
- Will not mark or scratch vehicle finishes
- Hose material is private branded and UL Listed to UL 330 and CAN/ULC-S612-99.
- All curb pump hose assemblies are 100% pressure tested, inspected for electrical continuity and sample pull tested



Wirebraid Hoses

MODEL NO.	DESCRIPTION	SHIPPING WEIGHT LBS (KG)
5/8" HOSES		
CP10WB08	5/8" Wirebraid 8' Assembly Hose	2.8 (1.3)
CP10WB09	5/8" Wirebraid 9" Assembly Hose	0.26 (0.12)
CP10WB09.5	5/8" Wirebraid 9.5' Assembly Hose	3.3 (1.5)
CP10WB10	5/8" Wirebraid 10' Assembly Hose	3.5 (1.6)
CP10WB14	5/8" Wirebraid 14' Assembly Hose	4.9 (2.2)
3/4" HOSES		
CP12WB04	3/4" Wirebraid 4' Assembly Hose	1.7 (0.8)
CP12WB05	3/4" Wirebraid 5' Assembly Hose	2.1 (1.0)
CP12WB06	3/4" Wirebraid 6' Assembly Hose	2.5 (1.1)
CP12WB08	3/4" Wirebraid 8' Assembly Hose	3.4 (1.5)
CP12WB09	3/4" Wirebraid 9' Assembly Hose	3.8 (1.7)
CP12WB09SV	3/4" Wirebraid 9' Assembly Hose Swivel	3.8 (1.7)
CP12WB10	3/4" Wirebraid 10' Assembly Hose	4.2 (1.9)
CP12WB12	3/4" Wirebraid 12' Assembly Hose	5.0 (2.3)
CP12WB12SV	3/4" Wirebraid 12' Assembly Hose Swivel	5.0 (2.3)
CP12WB12X	3/4" Wirebraid 12' Assembly Hose Bulk	5.0 (2.3)
CP12WB14	3/4" Wirebraid 14' Assembly Hose	5.9 (2.7)
CP12WB15SV	3/4" Wirebraid 15' Assembly Hose Swivel	6.3 (2.9)
CP12WB16	3/4" Wirebraid 16' Assembly Hose	6.7 (3.0)
CP12WB20	3/4" Wirebraid 20' Assembly Hose	8.4 (3.8)
CP12WB14L	3/4" Wirebraid 14' Assembly Hose	5.9 (2.7)
CP12WB14SV	3/4" Wirebraid 14' Assembly Hose Swivel	5.9 (2.7)
CP12WB14LSV	3/4" Wirebraid 14' Assembly Hose Swivel	5.9 (2.7)
1" HOSES		
CP16WB04	1" Wirebraid 4' Assembly Hose	2.0 (0.9)
CP16WB06	1" Wirebraid 6' Assembly Hose	3.0 (1.4)
CP16WB08	1" Wirebraid 8' Assembly Hose	4.0 (1.8)
CP16WB09	1" Wirebraid 9' Assembly Hose	4.5 (2.0)
CP16WB10	1" Wirebraid 10' Assembly Hose Bulk	5.0 (2.3)
CP16WB10X	1" Wirebraid 10' Assembly Hose	5.0 (2.3)
CP16WB100SV	1" Wirebraid 100' Assembly Hose Swivel	50.0 (22.7)
CP16WB12	1" Wirebraid 12' Assembly Hose	6.0 (2.7)
CP16WB12SV	1" Wirebraid 12' Assembly Hose Swivel	6.0 (2.7)
CP16WB13	1" Wirebraid 13' Assembly Hose	6.5 (3.0)
CP16WB14	1" Wirebraid 14' Assembly Hose	7.0 (3.2)
CP16WB14X	1" Wirebraid 14' Assembly Hose Bulk	7.0 (3.2)
CP16WB16	1" Wirebraid 16' Assembly Hose	8.0 (3.6)
CP16WB18	1" Wirebraid 18' Assembly Hose	9.0 (4.1)
CP16WB18X	1" Wirebraid 18' Assembly Hose Bulk	9.0 (4.1)
CP16WB20	1" Wirebraid 20' Assembly Hose	10.0 (4.5)
CP16WB20X	1" Wirebraid 20' Assembly Hose Bulk	10.0 (4.5)
CP16WB30	1" Wirebraid 30' Assembly Hose	15.0 (6.8)
CP16WB50SV	1" Wirebraid 50' Assembly Hose Swivel	25.0 (11.3)

Construction

Tube	Black Nitrile
Cover	Black CPE (chlorinated polyethylene), wrap impression
Reinforcement	One wirebraid with full diameter grounding sheath
Temperature Range	-40° F to +180° F (-40° C to +82° C)



WARNING: Cancer and Reproductive Harm - www.P65Warnings.ca.gov

EagleFlex® Wirebraid

Premium Hardwall Gasoline Pump Hose

Dimensions and System Options

Available in these Sizes

Size	ID		NOM OD		MAX WP		WEIGHT	
	MM	IN	MM	IN	PSI	MPA	LB/FT	KG/M
5/8"	16	0.97	25		150	1.03	0.35	0.52
3/4"	19	1.10	28		150	1.03	0.42	0.63
1"	25	1.34	34		150	1.03	0.50	0.74

Couplings

Permanent internally expanded fixed chrome plated brass (X type) or external crimp zinc (L type).

Reattachable fixed (R type) and reattachable swivel (SV type) 3/4" and 1" male NPT. U L does not recognize field installation of reattachable fittings.

External crimp zinc swivel 3/4" and 1" male NPT (L SV type) or 3/4" male BSPP (L SVB type).



EagleFlex[®] Farm Tank

Gasoline Hose Assemblies with Static Wire

- Designed for durability and flexibility
- Oil and abrasion resistant
- Supplied with static wire
- Recommended for use with electric pumps
- Static wire hose always recommended with electric motors
- Designed for use in agricultural, industrial and construction maintenance applications
- Engineered for dispensing gasoline, diesel, kerosene and oil from farm and barrel-type pumps where UL approval is not required
- Curb pump hose recommended for:
 - UL Listed hose material requirements
 - For high aromatics or severe applications
- All Farm Tank hose assemblies are 100% inspected for electrical continuity.
- Do not use these hoses at a service station or to refuel aircraft.

Farm Fueling Hoses

MODEL NO.	DESCRIPTION	SHIPPING WEIGHT LBS (KG)
3/4" HOSES		
FT012S10	3/4" x 10' Farm Tank Assembly Hose Bulk	2.9 (1.3)
FT012S12	3/4" x 12' Farm Tank Assembly Hose Bulk	3.5 (1.6)
FT012S12B	3/4" x 12' Farm Tank Assembly Hose Boxed	3.5 (1.6)
FT012S14	3/4" x 14' Farm Tank Assembly Hose Bulk	4.1 (1.9)
FT012S14B	3/4" x 14' Farm Tank Assembly Hose Boxed	4.1 (1.9)
FT012S15	3/4" x 15' Farm Tank Assembly Hose Bulk	4.4 (2.0)
FT012S15B	3/4" x 15' Farm Tank Assembly Hose Boxed	4.4 (2.0)
FT012S17	3/4" x 17' Farm Tank Assembly Hose Bulk	4.9 (2.2)
FT012S20	3/4" x 20' Farm Tank Assembly Hose Bulk	5.8 (2.6)
FT012S20B	3/4" x 20' Farm Tank Assembly Hose Boxed	5.8 (2.6)
1" HOSES		
FT016S10	1" x 10' Farm Tank Assembly Hose Bulk	4.5 (2.0)
FT016S12	1" x 12' Farm Tank Assembly Hose Bulk	5.4 (2.4)
FT016S12B	1" x 12' Farm Tank Assembly Hose Boxed	5.4 (2.4)
FT016S14	1" x 14' Farm Tank Assembly Hose Bulk	6.3 (2.9)
FT016S15	1" x 15' Farm Tank Assembly Hose Bulk	6.8 (3.1)
FT016S15B	1" x 15' Farm Tank Assembly Hose Boxed	6.8 (3.1)
FT016S17	1" x 17' Farm Tank Assembly Hose Bulk	7.7 (3.5)
FT016S20	1" x 20' Farm Tank Assembly Hose Bulk	9.0 (4.1)
FT016S20B	1" x 20' Farm Tank Assembly Hose Boxed	9.0 (4.1)
FT016S25	1" x 25' Farm Tank Assembly Hose Bulk	11.3 (5.1)

Construction

Tube	NBR, RMA Class A
Cover	NBR/PVC RMA Class A
Reinforcement	Spiral high tensile strength polyester cord
Temperature Range	-20° F to +160° F (-29° C to +71° C)



WARNING: Cancer and Reproductive Harm - www.P65Warnings.ca.gov

EagleFlex® Farm Tank

Gasoline Hose Assemblies with Static Wire

Dimensions and System Options

Available in these Sizes

Size	ID MM	NOM OD		WEIGHT	
		IN	MM	LB/FT	KG/M
3/4"	19	1.13	29	0.29	0.43
1"	25	1.38	35	0.45	0.67

Couplings

Permanent externally crimped 3/4" and 1" NPT.



Whip Hoses

HARDWALL WHIP HOSE:

- Recommended anywhere a hardwall hose is required
- Highly resistant to cuts, abrasions, sun and weather
- Improves ozone and abrasion resistance while providing increased life

WIREBRAID WHIP HOSE:

- Recommended anywhere a hardwall or softwall hose is inappropriate
- Provides full flow with no internal spring guards and will withstand full suction
- Highly resistant to cuts, abrasions, sun and weather
- Flexibility of a softwall, durability of a hardwall

SOFTWALL WHIP HOSE:

- A lightweight, flexible hose for use when a hardwall hose is inappropriate
- Highly resistant to cuts, abrasions, sun and weather

ALL WHIP HOSES:

- Recommended for all gasoline and gasoline/Ethanol blends at Ethanol levels designated as “gasohol” (E15 maximum or less), diesel fuel and diesel fuel/biodiesel blends with nominal biodiesel concentrations up to 20% (B0-B20), kerosene and fuel oil (heating oil), leaded and unleaded gasoline
- Hose Material is private branded and UL listed.
- All curb pump hose assemblies are 100% pressure tested, inspected for electrical continuity and sample pull tested.

Whip Hoses

MODEL NO.	DESCRIPTION	SHIPPING WEIGHT LBS (KG)
5/8" HOSES		
CP10HW.75	5/8" Hardwall 9" Assembly Hose	0.3 (0.14)
CP10HW.75L	5/8" Hardwall low cost 9" Assembly Hose	0.3 (0.14)
CP10WB.75M	5/8" Wirebraided medium cost 9" Assembly Hose	0.3 (0.14)
CP10WB.75SV	5/8" Wirebraided Swivel 9" Assembly Hose	0.3 (0.14)
3/4" HOSES		
CP12HW.75	3/4" Hardwall 9" Assembly Hose	0.3 (0.14)
CP12HWG.75	3/4" Green Hardwall 9" Assembly Hose	0.3 (0.14)
CP12HW.75L	3/4" Hardwall low cost 9" Assembly Hose	0.3 (0.14)
CP12HW.75SV	3/4" Hardwall Swivel 9" Assembly Hose	0.3 (0.14)
CP12WB.75L	3/4" Wirebraided low cost 9" Assembly Hose	0.3 (0.14)
CP12WB.75SV	3/4" Wirebraided Swivel 9" Assembly Hose	0.3 (0.14)
1" HOSES		
CP16HW.75	1" Hardwall 9" Assembly Hose	0.5 (0.23)
CP16HW.75L	1" Hardwall low cost 9" Assembly Hose	0.5 (0.23)
CP16HW.75SV	1" Hardwall Swivel 9" Assembly Hose	0.5 (0.23)
CP16WB.75L	1" Wirebraided low cost 9" Assembly Hose	0.5 (0.23)
CP16WB.75SV	1" Wirebraided Swivel 9" Assembly Hose	0.5 (0.23)



WARNING: Cancer and Reproductive Harm - www.P65Warnings.ca.gov

Whip Hoses

Dimensions



DEF Dispensing

DEF hose assemblies without static wire

- Designed for durability and flexibility
- Abrasion resistant
- Supplied without static wire
- Recommended for use with electric pumps or dispensers
- Designed for any DEF dispensing applications.
- Engineered for dispensing DEF where UL approval is not required
- Curb pump hose recommended for:
 - UL Listed hose material requirements
 - For high aromatics or severe applications
- All DEF hose assemblies are 100% inspected for pressure to 50 psi.

(See page two for coupling descriptions)



GP/GPM TYPE

AN TYPE

ANB/ANF TYPE

ANF/ANMF TYPE

DEF Fueling Hoses

MODEL NO.	DESCRIPTION	SHIPPING WEIGHT LBS (KG)
3/4" HOSES		
CP12DF10GP	3/4" x 10' DEF Assembly Hose	2.9 (1.3)
CP12DF12GP	3/4" x 12' DEF Assembly Hose	3.5 (1.6)
CP12DF12GPX	3/4" x 12' DEF Assembly Hose Bulk	3.5 (1.6)
CP12DF14GP	3/4" x 14' DEF Assembly Hose	4.1 (1.9)
CP12DF15GPX	3/4" x 15' DEF Assembly Hose Bulk	4.4 (2.0)
CP12DF17GP	3/4" x 17' DEF Assembly Hose	4.9 (2.2)
CP12DF20GP	3/4" x 20' DEF Assembly Hose	5.8 (2.6)
CP12DF20GPX	3/4" x 20' DEF Assembly Hose Bulk	5.8 (2.6)
CP12DF10AN	3/4" x 10' DEF Assembly Hose w/ 3/4" NPT aluminum fittings	2.9 (1.3)
CP12DF10ANB	3/4" x 10' DEF Assembly Hose with 3/4" BSPP Aluminum Fittings	2.9 (1.3)
CP12DF10ANF	3/4" x 10' DEF Assembly Hose with 1" Female BSPP Fittings	2.9 (1.3)

Construction

Tube	Black customized peroxide-cured EPDM
Cover	Black customized EPDM with smooth finish
Reinforcement	Multiple textile plies
Temperature Range	-40° F to +212° F (-40° C to +100° C)



WARNING: Cancer and Reproductive Harm - www.P65Warnings.ca.gov

DEF Dispensing

DEF hose assemblies without static wire

Dimensions and System Options

Available in these Sizes

ID		NOM OD		MAX WP		WEIGHT	
Size	MM	IN	MM	LB/FT	KG/M	LB/FT	KG/M
3/4"	19	1.13	29	150	1.03	0.29	0.43

Couplings

Permanent externally crimped 3/4" NPT polypropylene stem with brass ferrule (GP type) or 3/4" BSPP (GPM type)

Permanent externally crimped 3/4" NPT anodized aluminum stem with stainless steel ferrule (AN type)

Permanent externally crimped 3/4" BSPP anodized aluminum stem with stainless steel ferrule (ANB type)

Permanent externally crimped 1" female BSPP anodized aluminum stem with stainless steel ferrule (ANF type)

Permanent externally crimped 1" female & 3/4" male BSPP anodized aluminum stems with stainless steel ferrules (ANB type)



EagleFlex® Low Perm Hardwall

Premium Low Permeation Hardwall Gasoline Pump Hose

- Recommended anywhere a hardwall hose is required
- Resists kinking and eliminates meter creep
- Recommended for all gasoline and gasoline/Ethanol blends at Ethanol levels designated as “gasohol” (E10 maximum or less), diesel fuel and diesel fuel/biodiesel blends with nominal biodiesel concentrations up to 5% (B0-B5), kerosene and fuel oil (heating oil), leaded and unleaded gasoline where low permeation ($\leq 10\text{g}/\text{m}^2/\text{day}$) is required
- Improves ozone and abrasion resistance while providing increased life
- Improves draping and handling characteristics
- Will not mark or scratch vehicle finishes
- Hose material is private branded and UL Listed to UL 330 for low permeation.
- All curb pump hose assemblies are 100% pressure tested, inspected for electrical continuity and sample pull tested.
- Designed for durability, flexibility, and easy handling
- Highly resistant to cuts, abrasions, sun and weather

Low Perm Hardwall Hoses

MODEL NO.	DESCRIPTION	SHIPPING WEIGHT LBS (KG)
5/8" LP HOSES		
CP10LP8.5	5/8" Low Perm Hardwall 8.5' Assembly Hose	3.8 (1.7)
CP10LP10	5/8" Low Perm Hardwall 10' Assembly Hose	4.7 (2.1)
3/4" LP HOSES		
CP12LP8.5	3/4" Low Perm Hardwall 8.5' Assembly Hose	3.8 (1.7)
CP12LP8.5SV	3/4" Low Perm Hardwall 8.5' Assembly Hose Swivel	4.2 (1.9)
CP12LP9	3/4" Low Perm Hardwall 9' Assembly Hose	4.2 (1.9)
CP12LP9SV	3/4" Low Perm Hardwall 9' Assembly Hose Swivel	4.7 (2.1)
1" LP HOSES		
CP16LP8	1" Low Perm Hardwall 8' Assembly Hose	6.4 (2.9)
CP16LP14	1" Low Perm Hardwall 14' Assembly Hose	9.6 (4.4)

Construction

Tube	Black Nitrile
Cover	Black CPE (Chlorinated Polyethylene), wrap impression
Reinforcement	Multiple textile braids with dual static wire helix
Temperature Range	-40°F to +180°F (-40°C to +82°C)



WARNING: Cancer and Reproductive Harm - www.P65Warnings.ca.gov

EagleFlex® Low Perm Hardwall

Premium Low Permeation Hardwall Gasoline Pump Hose

Dimensions and System Options

Available in these Sizes

ID Size MM	NOM OD		MAX WP		WEIGHT	
	IN	MM	PSI	MPA	LB/FT	KG/M
5/8" 16	1.03	26	150	1.03	0.37	0.55
3/4" 19	1.17	30	150	1.03	0.44	0.65
1" 25	1.45	37	150	1.03	0.59	0.88

Couplings

Permanent, external crimp, zinc plated steel couplings, fixed and swivel



Whip Low Perm Hoses

- Recommended anywhere a hardwall hose is required
- Recommended for all gasoline and gasoline/Ethanol blends at Ethanol levels designated as “gasohol” (E10 maximum or less), diesel fuel and diesel fuel/biodiesel blends with nominal biodiesel concentrations up to 5% (B0-B5), kerosene and fuel oil (heating oil), leaded and unleaded gasoline where low permeation ($\leq 10\text{g/m}^2/\text{day}$) is required
- Designed for durability, flexibility, and easy handling
- Highly resistant to cuts, abrasions, sun and weather
- Resists kinking and eliminates meter creep
- Improves ozone and abrasion resistance while providing increased life
- Will not mark or scratch dispenser finishes
- Hose material is private branded and UL Listed to UL 330 for low permeation.
- All curb pump hose assemblies are 100% pressure tested, inspected for electrical continuity and sample pull tested.

Whip Low Perm Hoses

MODEL NO.	DESCRIPTION	SHIPPING WEIGHT LBS (KG)
5/8" LP HOSES		
CP10LP.75	5/8" Low Perm Hardwall 9" Assembly Hose	0.72 (0.3)
CP10LP.75SV	5/8" Low Perm Hardwall 9" Swivel Assembly Hose	0.72 (0.3)
3/4" LP HOSES		
CP12LP.75	3/4" Low Perm Hardwall 9" Assembly Hose	1.00 (0.5)
CP12LP.75SV	3/4" Low Perm Hardwall 9" Swivel Assembly Hose	1.00 (0.5)
1" LP HOSES		
CP16LP.75	1" Low Perm Hardwall 9" Assembly Hose	1.20 (0.5)
CP16LP.75SV	1" Low Perm Hardwall 9" Swivel Assembly Hose	1.20 (0.5)



WARNING: Cancer and Reproductive Harm - www.P65Warnings.ca.gov

Whip Low Perm Hoses

Dimensions and System Options

Available in these Sizes

ID Size MM	NOM OD		MAX WP		WEIGHT	
	IN	MM	PSI	MPA	LB/FT	KG/M
5/8" 16	1.03	26	150	1.03	0.37	0.55
3/4" 19	1.17	30	150	1.03	0.44	0.65
1" 25	1.45	37	150	1.03	0.59	0.88

Couplings

Permanent, external crimp, zinc plated steel couplings, fixed and swivel



Fuel Oil Hose

Fuel Oil Permanent Fitting fueling hose recommended for all home fuel oils, leaded and unleaded gasolines, and diesel and tractor fuels.

- Used for all home fuel oils, leaded and unleaded gasolines, and diesel and tractor fueling applications
- All fuel oil hose assemblies are 100% hydrostatic tested.
- Resistant to flex fatigue
- Smooth cover gives it minimum ground drag, added freedom of movement and abrasion resistance

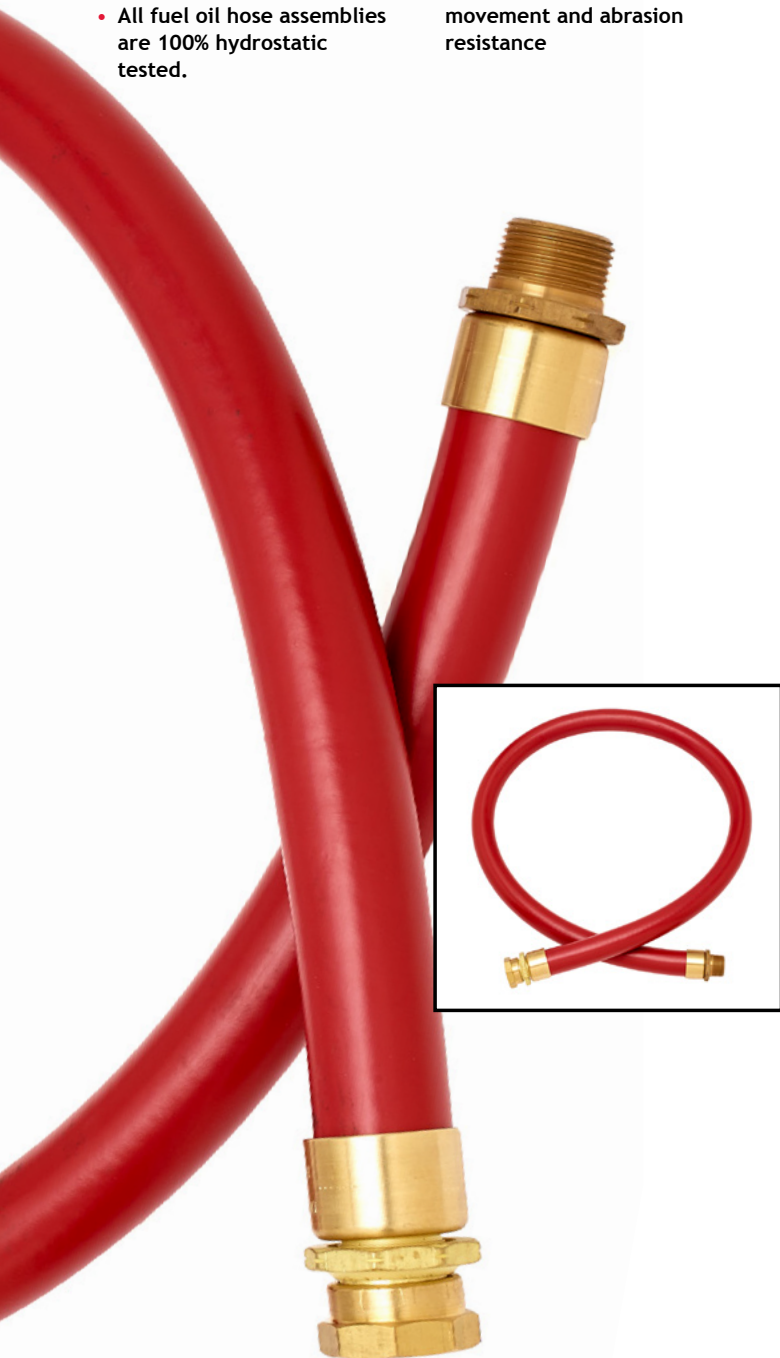

Specifying Information

MODEL NO.	DESCRIPTION	SHIPPING WEIGHT LBS (KG)
1" BULK HOSES		
9769	Hose, 1" Red Fuel Oil 100'	47 (21.3)
9769	Hose, 1" Red Fuel Oil 125'	59 (26.8)
9769	Hose, 1" Red Fuel Oil 150'	71 (32.2)
1 1/4" BULK HOSES		
9770	Hose, 1 1/4" Red Fuel Oil 100'	59 (26.8)
9770	Hose, 1 1/4" Red Fuel Oil 125'	74 (33.6)
9770	Hose, 1 1/4" Red Fuel Oil 150'	89 (40.4)
1 1/2" BULK HOSES		
9771	Hose, 1 1/2" Red Fuel Oil 100'	80 (36.3)
9771	Hose, 1 1/2" Red Fuel Oil 125'	100 (45.4)
9771	Hose, 1 1/2" Red Fuel Oil 150'	120 (54.4)
1" HOSES		
CP161200FABA	1" x 100' Red Fuel Oil Assy M x M	49 (22.2)
CP161200FBBA	1" x 100' Red Fuel Oil Assy M x F	49 (22.2)
CP161200FCBA	1" x 100' Red Fuel Oil Assy F x F	49 (22.2)
CP161500FABA	1" x 125' Red Fuel Oil Assy M x M	61 (27.7)
CP161500FBBA	1" x 125' Red Fuel Oil Assy M x F	61 (27.7)
CP161500FCBA	1" x 125' Red Fuel Oil Assy F x F	61 (27.7)
CP161800FABA	1" x 150' Red Fuel Oil Assy M x M	73 (33.1)
CP161800FBBA	1" x 150' Red Fuel Oil Assy M x F	73 (33.1)
CP161800FCBA	1" x 150' Red Fuel Oil Assy F x F	73 (33.1)
1 1/4" HOSES		
CP201200FABA	1 1/4" x 100' Red Fuel Oil Assy M x M	61 (27.7)
CP201200FBBA	1 1/4" x 100' Red Fuel Oil Assy M x F	61 (27.7)
CP201200FCBA	1 1/4" x 100' Red Fuel Oil Assy F x F	61 (27.7)
CP201500FABA	1 1/4" x 125' Red Fuel Oil Assy M x M	76 (34.5)
CP201500FBBA	1 1/4" x 125' Red Fuel Oil Assy M x F	76 (34.5)
CP201500FCBA	1 1/4" x 125' Red Fuel Oil Assy F x F	76 (34.5)
CP201800FABA	1 1/4" x 150' Red Fuel Oil Assy M x M	91 (41.3)
CP201800FBBA	1 1/4" x 150' Red Fuel Oil Assy M x F	91 (41.3)
CP201800FCBA	1 1/4" x 150' Red Fuel Oil Assy F x F	91 (41.3)
1 1/2" HOSES		
CP241200FABA	1 1/2" x 100' Red Fuel Oil Assy M x M	82 (37.2)
CP241200FBBA	1 1/2" x 100' Red Fuel Oil Assy M x F	82 (37.2)
CP241200FCBA	1 1/2" x 100' Red Fuel Oil Assy F x F	82 (37.2)
CP241500FABA	1 1/2" x 125' Red Fuel Oil Assy M x M	102 (46.3)
CP241500FBBA	1 1/2" x 125' Red Fuel Oil Assy M x F	102 (46.3)
CP241500FCBA	1 1/2" x 125' Red Fuel Oil Assy F x F	102 (46.3)
CP241800FABA	1 1/2" x 150' Red Fuel Oil Assy M x M	122 (55.3)
CP241800FBBA	1 1/2" x 150' Red Fuel Oil Assy M x F	122 (55.3)
CP241800FCBA	1 1/2" x 150' Red Fuel Oil Assy F x F	122 (55.3)

Construction

Tube	NBR, RMA Class A
Cover	NBR/PVC, RMA Class A
Reinforcement	4 spiral polyester yarn
Cover Color:	Red
Oil Resistance:	High, Medium-High
Temperature:	-20° F (-29° C) to +180° F (82° C)



WARNING: Cancer and Reproductive Harm - www.P65Warnings.ca.gov

Fuel Oil Hose

Fuel Oil Permanent Fitting fueling hose recommended for all home fuel oils, leaded and unleaded gasolines, and diesel and tractor fuels.

Dimensions and System Options

Available in these Sizes

ID		NOM OD		MAX WP		WEIGHT	
Size	MM	IN	MM	PSI	MPA	LB/FT	KG/M
1"	25	1.50	38.0	250	1.72	0.47	0.71
1 1/4"	32	1.78	45.2	250	1.72	0.59	0.87
1 1/2"	38	2.06	52.3	250	1.72	0.80	1.19

Couplings

Permanent Brass	Internally expanded fittings - male NPT and female NPS (swivel nut)
-----------------	---

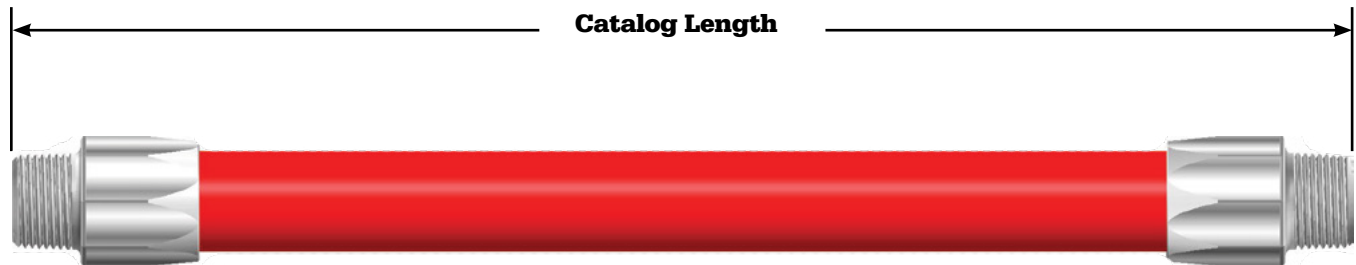

EagleFlex® E0-E85

E0-E85 Curb Pump Hose

- Recommended for use with Ethanol blends from E0 to E85
- Resistant to crushing and stands up to run-over
- Highly resistant to cuts, abrasions, sun and weather
- Flexibility of a softwall, durability of a hardwall
- Assures accurate readings at the pump
- Will not mark or scratch vehicle finishes
- Hose material is private branded and UL Listed to UL 330A and CAN/ULC-S612-99.
- All curb pump hose assemblies are 100% pressure tested, inspected for electrical continuity and sample pull tested.

E0-E85 Wirebraided Hoses

MODEL NO.	DESCRIPTION	SHIPPING WEIGHT LBS (KG)
3/4" HOSES		
CP12ET04	3/4" E0-E85 4' Assembly Hose	1.7 (0.8)
CP12ET05	3/4" E0-E85 5' Assembly Hose	2.1 (1.0)
CP12ET06	3/4" E0-E85 6' Assembly Hose	2.5 (1.1)
CP12ET09	3/4" E0-E85 9' Assembly Hose	3.8 (1.7)
CP12ET10	3/4" E0-E85 10' Assembly Hose	4.2 (1.9)
CP12ET10X	3/4" E0-E85 10' Assembly Hose Bulk	4.2 (1.9)
CP12ET12	3/4" E0-E85 12' Assembly Hose	5.0 (2.3)
CP12ET12X	3/4" E0-E85 12' Assembly Hose Bulk	5.0 (2.3)
CP12ET14	3/4" E0-E85 14' Assembly Hose	5.9 (2.7)
CP12ET16	3/4" E0-E85 16' Assembly Hose	6.7 (3.0)
CP12ET20	3/4" E0-E85 20' Assembly Hose	8.4 (3.8)
CP12ET50X	3/4" E0-E85 50' Assembly Hose Bulk	21.0 (9.5)

Whip Hoses

MODEL NO.	DESCRIPTION	SHIPPING WEIGHT LBS (KG)
3/4" HOSES		
CP12ET.75	3/4" E85 9" Assembly Hose	0.86 (0.39)
CP12ET.66	3/4" E85 8" Assembly Hose	0.82 (0.37)

Construction

Tube	Black Nitrile
Cover	Black CPE (chlorinated polyethylene), wrap impression
Reinforcement	One wirebraid with full diameter grounding sheath
Temperature Range	-40°F to +180°F (-40°C to +82°C)



 WARNING: Cancer and Reproductive Harm - www.P65Warnings.ca.gov

EagleFlex® E0-E85

E0-E85 Curb Pump Hose

Dimensions and System Options

Available in these Sizes

ID Size	NOM OD		MAX WP		WEIGHT	
	MM	IN	PSI	MPA	LB/FT	KG/M
3/4" 19	1.10	28	150	1.03	0.42	0.63

Couplings

Permanent externally crimped zinc (L type).





GENERAL FUELING PRODUCTS

EZ-Connect[®]

The only certified, pre-assembled, pressure and continuity-tested hanging hardware.

- Stage II Decommissioning Ready
- Can also be configured for new station installs
- Fully customizable
- Available in 5/8", 3/4" and 1" assemblies
- Pre-fabricated hanging hardware assembly
- Includes choice of Hose/Dispenser adaptor (Balanced/Vac-Assist/Heavy)
- Robust multi-plane Husky[®] swivel
- 3 types of hose material offered: Hardwall, Wirebraid and Softwall
- Zinc fittings
- Chrome-plated brass fittings
- EZ-Connect[®] hoses assembled with UL/CUL certified components
- Your choice of nozzle configuration
- 100% continuity/pressure tested
- Thread sealant used on all component connections (Gasola[®])
- All required hanging hardware for decommissioning in one single package



⚠ WARNING: Cancer and Reproductive Harm - www.P65Warnings.ca.gov

EZ-Connect®

For nozzles and Safe-T-Breaks®

Thousands of conventional fuel pump combinations are available with **EZ-Connect's®** six interchangeable components, making it possible to design a pump package to meet specific fuel-dispensing needs.

This sample chart, using 5/8" Hardwall Hoses, demonstrates the many options available:			
5/8" Connections/9' Hardwall Hoses Kits			
	w/002273 (Single Use) STB	w/003360 Reconnectable STB	w/008330 MagBreak®
Balance to Conventional Adaptor	006959	006959	006959
5/8" x 9" Hardwall Whip Hose	CP10HW.75	CP10HW.75	CP10HW.75
Safe-T-Break®	002273	003360	008330
5/8" x 9' Hardwall Curb Hose	CP10HW09	CP10HW09	CP10HW09
3/4" Multi-Plane Swivel	000350	000350	000350
New XS® Pressure Activated Automatic Nozzle w/1808 Splash Guard	159559	159559	159559
5/8" Connections/10' Hardwall Hoses Kits			
	w/002273 (Single Use) STB	w/003360 Reconnectable STB	w/008330 MagBreak®
Balance to Conventional Adaptor	006959	006959	006959
5/8" x 9" Hardwall Whip Hose	CP10HW.75	CP10HW.75	CP10HW.75
Safe-T-Break®	002273	003360	008330
5/8" x 10' Hardwall Curb Hose	CP10HW10	CP10HW10	CP10HW10
3/4" Multi-Plane Swivel	000350	000350	000350
New XS® Pressure Activated Automatic Nozzle w/1808 Splash Guard	159559	159559	159559
This sample chart, using 3/4" Softwall DEF Hoses, demonstrates the many options available:			
New X DEF Nozzle w/ 3/4" NPT Connections/9' Softwall DEF Hose Kits^			
	w/012070 Reconnectable STB		
3/4" 9" Softwall DEF Whip Hose	CP12DF.75AN		
Safe-T-Break®	012070		
3/4" 9' Softwall DEF Hose	CP12DF09AN		
3/4" Roller Bearing Swivel	012604		
New X DEF Automatic Nozzle w/004809 Splash Guard	11676155N		
New X DEF Nozzle w/ 3/4" NPT Connections/9' Softwall DEF Hose Kits^			
	w/012070 Reconnectable STB		
3/4" 9" Softwall DEF Whip Hose	CP12DF.75AN		
Safe-T-Break®	012070		
3/4" 9' Softwall DEF Hose	CP12DF09AN		
3/4" Roller Bearing Swivel	012604		
New X DEF Automatic Nozzle w/004809 Splash Guard New X DEF Automatic Nozzle w/004809 Splash Guard	11676155N		
New Polymer DEF Nozzle w/ 3/4" NPT Connections/9' Softwall DEF Hose Kits^			
	w/012070 Reconnectable STB		
3/4" 9" Softwall DEF Whip Hose	CP12DF.75GP		
Safe-T-Break®	012070		
3/4" 9' Softwall DEF Hose	CP12DF09PB		
New Polymer DEF Automatic Nozzle w/000216 Splash Guard	873504N		
New X DEF Nozzle w/ 3/4" BSPP Connections/9' Softwall DEF Hose Kits^			
	w/012659 Reconnectable STB		
3/4" 9" Softwall DEF Whip Hose	CP12DF.75AB		
Safe-T-Break®	012659		
3/4" 9' Softwall DEF Hose	CP12DF09AB		
3/4" Roller Bearing Swivel	012656		
New X DEF Automatic Nozzle w/001808 Splash Guard, w/007361 Handle Guard	11676154N		

^Not Listed

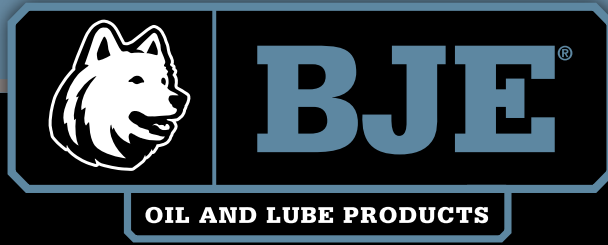

BJE Catalog

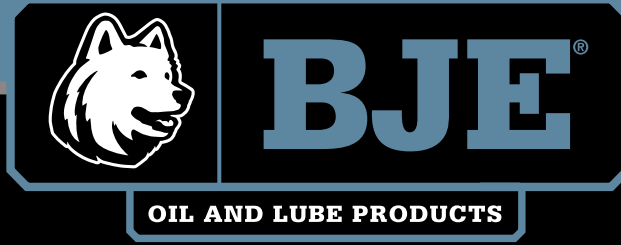

Crushers

C-4 Crusher

C-4 Pneumatic Oil Filter Crusher for automobile filters.

- Reduces filters by 75% of original size, and removes 95% of the free-flowing oil so it can be recycled
- Crushing chamber accepts filters 7-1/2" tall x 5" diameter
- Only one moving part, a 1-1/2" shaft
- Safety door - crusher will not operate if door is opened
- Cycle time: 5 seconds
- Air requirement: 125 to 175 PSI
- Air regulator not needed
- Oiler and lubricator not needed
- All parts in contact with air are rust proof.
- Optional stand (sold separately)
- Overall size: 26" high, 11" wide, 11" deep
- Lifetime warranty on housing, one year limited on all other parts
- 12" Flexible drain hose included
- Wall mounting brackets included
- Crusher weight 108 lbs. (shipping weight 160 lbs. shipped UPS)

New Crushers

MODEL NO.	DESCRIPTION	SHIPPING WEIGHT LBS (KG)
007605	C-4 Pneumatic Automobile Oil Filter Crusher	108 (48.9)
007590	Small Crusher Stand for C-4 and C-6 Oil Filter Crushers	101 (45.8)
008203	C-4 Pneumatic Automobile Oil Filter Crusher (007605) with Crusher Stand (007590)	219 (99.3)



Model 007590



Model 007605



⚠ WARNING: Cancer and Reproductive Harm - www.P65Warnings.ca.gov

C-4 Crusher

C-4 Pneumatic Oil Filter Crusher for automobile filters.

Dimensions and System Options

Repair Parts

MODEL NO.	DESCRIPTION
007589	C4, C6 90 degree Elbow
007599	C4, C6 TT12 Ball Valve
007602	C4 8" Black Cylinder
007611	C4 Cup Plate
007614	C4 Push Plate
007612	C4 Door
007617	C4 Return Spring
007618	C4 Shaft
007619	C4 Top Bearing
007642	C4, C6 TT12 MJV-3 Air Clippard Valve
007708	C4, C6 3/8" Push-on Connector
007719	C4, C6, TT12 Muffler
007749	C4, C6, TT12 S1205 Safety Valve
007847	C4, C6 Handle
007853	C4 Air Tube / Galvanized Pipe
007859	C4 Neoprene Cup
007860	C4 8" Large O-Ring
007901	C4, C6 Reducer Bushing
007902	C4, C6, TT12 1-1/4" 12 Jam Nut
007903	C, C6, TT12 1-1/8" Washer
007904	C4, C6, TT12, TT25 3/8" Ball Bearing Switch
007905	C4, C6, TT12, TT25 Safety Switch Spring
007906	C4, C6, TT12, TT25 1/4" x 2-1/4" Clevis Pin
007907	C4, C6, TT12, TT25 3/8" ID x 1/2" OD Bearing
007908	C4, C6, TT12, TT25 1/4" x 1-1/2" Clevis Pin
007909	C4, C6, TT12, TT25 3/32" x 1/2" Cotter Pin
007914	C4 Drain Hose Adaptor
007917	C4, C6, TT12. TT25 3/8" x 2-1/4" Grade 8 Tap Bolt
007918	C4, C6. TT12, TT25 3/8" x 16 Stover Nut
007938	C4, C6, TT12, TT25 5/16" Flat Washer
007940	C4, C6, TT12 1/4" Air Hose Assembly

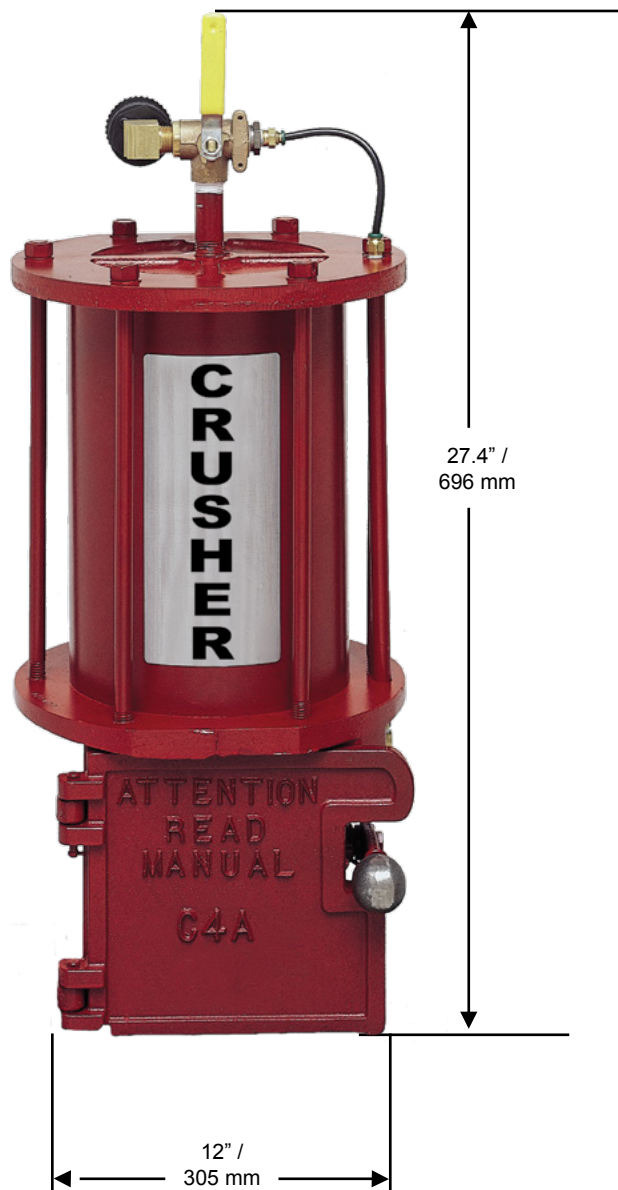

C-6 Crusher

C-6 Pneumatic Oil Filter Crusher for automobile filters.

- Reduces filters by 75% of original size, and removes 95% of the free-flowing oil so it can be recycled
- Large crushing chamber: accepts filters up to 10" tall x 7" diameter
- Only one moving part, a 2" shaft
- Safety door - crusher will not operate if door is opened
- Cycle time: 27 seconds
- Air requirement: 125 to 175 PSI
- Air regulator not needed
- Oiler and lubricator not needed
- All parts in contact with air are rust proof
- Optional stand (sold separately)
- Overall size on stand: 75" high, 36" wide, 26" deep
- Lifetime warranty on housing, one year limited on all other parts
- 12" Flexible drain hose included
- Overall weight on stand 170 lbs. (shipping weight 182 lbs. trucked on pallet)

New Crushers

MODEL NO.	DESCRIPTION	SHIPPING WEIGHT LBS (KG)
008207	C-6 Pneumatic SUV Oil Filter Crusher	221 (100.2)
007590	Smaller Crusher Stand for C-4 and C-6 Oil Filter Crushers	101 (45.9)
007610	C-6 Pneumatic SUV Oil Filter Crusher (008207) with Crusher Stand (007590)	281 (127.5)



Model 007590



Model 008207



⚠ WARNING: Cancer and Reproductive Harm - www.P65Warnings.ca.gov

C-6 Crusher

C-6 Pneumatic Oil Filter Crusher for light truck diesel and SUV filters.

Dimensions and System Options

Repair Parts

MODEL NO.	DESCRIPTION
007589	C-4, C6 90 degree Elbow
007599	C-4, C6 TT12 Ball Valve
007628	C-6 Cup Plate
007632	C-6 Push Plate
007629	C-6 Door
007858	C-6 Return Spring
007633	C-6 Shaft
007634	C-6 Top Bearing
007642	C-4, C-6 TT-12 MJV-3 Air Clippard Valve
007708	C-4, C-6 3/8" Push-on Connector
007719	C-4, C-6, TT-12 Muffler
007749	C-4, C-6, TT-12 S1205 Safety Valve
007847	C-4, C-6 Handle
007861	C-6 Neoprene Cup
007862	C-6 10" Large O-Ring
007901	C-4, C-6 Reducer Bushing
007902	C-4, C-6, TT-12 1-1/4" 12 Jam Nut
007903	C, C-6, TT-12 1-1/8" Washer
007904	C-4, C-6, TT-12, TT-25 3/8" Ball Bearing Switch
007905	C-4, C-6, TT-12, TT-25 Safety Switch Spring
007906	C-4, C-6, TT-12, TT-25 1/4" x 2-1/4" Clevis Pin
007907	C-4, C-6, TT-12, TT-25 3/8" ID x 1/2" OD Bearing
007908	C-4, C-6, TT-12, TT-25 1/4" x 1-1/2" Clevis Pin
007909	C-4, C-6, TT-12, TT-25 3/32" x 1/2" Cotter Pin
007917	C-4, C-6, TT-12, TT-25 3/8" x 2-1/4" Grade 8 Tap Bolt
007918	C-4, C-6, TT-12, TT-25 3/8" x 16 Stover Nut
007938	C-4, C-6, TT-12, TT-25 5/16" Flat Washer
007940	C-4, C-6, TT-12 1/4" Air Hose Assembly



TT-12 Crusher

Pneumatic Oil Filter Crusher for tractor trailer and truck filters.

- Reduces filters by 75% of original size, and removes 95% of the free-flowing oil so it can be recycled
- Only one moving part, a 2" shaft
- Safety door - crusher will not operate if door is opened
- Cycle time: 23 seconds
- Air requirement - 125 to 175 PSI
- Air regulator not needed
- Oiler and lubricator not needed
- All parts in contact with air are rust proof.
- Size: 51" high, 18" wide, 17" deep
- Lifetime warranty on housing, one year limited on all other parts
- Optional stand (sold separately)
- Crusher weight 358 lbs. with stand 470 lbs. (shipping weight 530 lbs. trucked on pallet.)
- Large crushing chamber: accepts filters up to 16" tall x 9" diameter

New Crushers

MODEL NO.	DESCRIPTION	SHIPPING WEIGHT LBS (KG)
007715	TT12 Pneumatic Truck Oil Filter Crusher	418 (189.6)
007550	Large Crusher Stand with Reservoir for C-6, TT12 and TT25 Oil Filter Crushers	172 (78)
008210	TT12 Pneumatic Truck Oil Filter Crusher (007715) with Crusher Stand with Reservoir (007550)	530 (240.4)



Model 007550



Model 007715



 WARNING: Cancer and Reproductive Harm - www.P65Warnings.ca.gov

TT-12 Crusher

Pneumatic Oil Filter Crusher for tractor trailer and truck filters.

Dimensions and System Options

Repair Parts

Model No.	Description
007599	C4, C6 TT12 Ball Valve
007644	TT12 Cylinder
007604	TT12 Bottom Plate
007863	TT12, TT25 Push Plate
007799	TT12 Door
007796	TT12 Return Spring
007800	TT12 Shaft
007642	C4, C6 TT12 MJV-3 Air Clippard Valve
007719	C4, C6, TT12 Muffler
007749	C4, C6, TT12 S1205 Safety Valve
007793	TT12 Handle
007856	TT12 1/2" OD x .062 Tubing
007795	TT12 12" Piston Cup
007794	TT12 12" Large O-Ring
007902	C4, C6, TT12 1-1/4" 12 Jam Nut
007903	C, C6, TT12 1-1/8" Washer
007904	C4, C6, TT12, TT25 3/8" Ball Bearing Switch
007905	C4, C6, TT12, TT25 Safety Switch Spring
007906	C4, C6, TT12, TT25 1/4" x 2-1/4" Clevis Pin
007907	C4, C6, TT12, TT25 3/8" ID x 1/2" OD Bearing
007908	C4, C6, TT12, TT25 1/4" x 1-1/2" Clevis Pin
007909	C4, C6, TT12, TT25 3/32" x 1/2" Cotter Pin
007917	C4, C6, TT12. TT25 3/8" x 2-1/4" Grade 8 Tap Bolt
007918	C4, C6. TT12, TT25 3/8" x 16 Stover Nut
007938	C4, C6, TT12, TT25 5/16" Flat Washer
007940	C4, C6, TT12 1/4" Air Hose Assembly

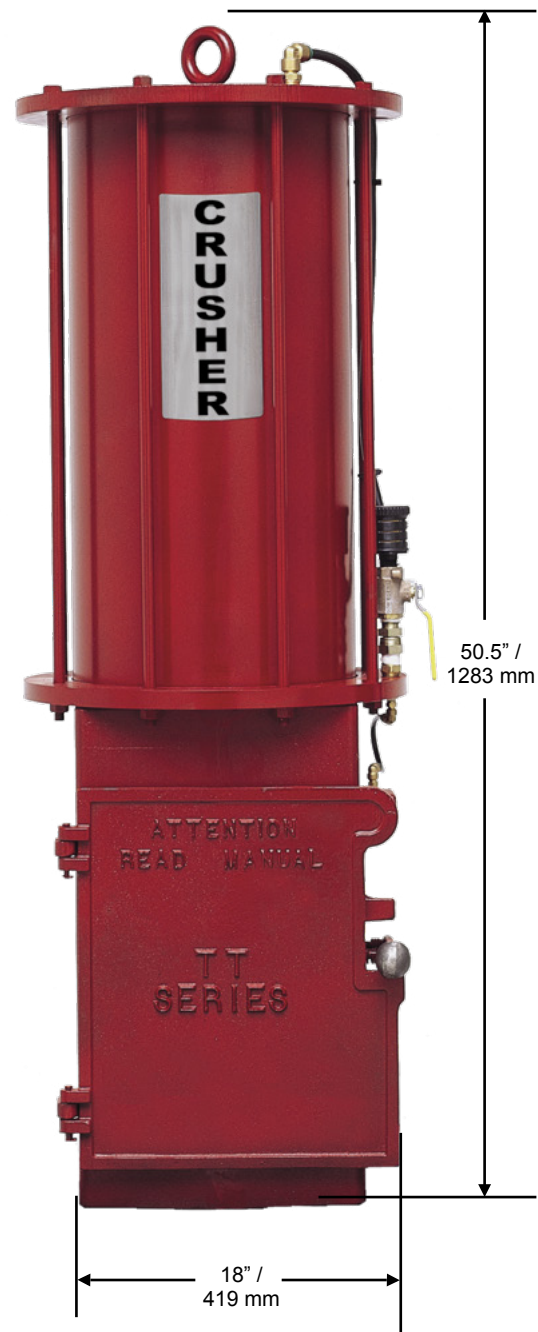

TT-25 Crusher

Electric Hydraulic Oil Filter Crusher for tractor trailer and truck filters.

- Reduces filters by 75% of original size, and removes 95% of the free-flowing oil so it can be recycled
- Large crushing chamber: accepts filters up to 16" tall x 9" diameter
- Automatic crushing cycle
- Cycle time: 1 minute
- Pump: 1 Phase/ 230V/60Hz or 1 Phase 220V/50Hz
- Safety door - crusher will not operate if door is opened
- Overall size on optional stand: 87" high, 23" wide, 31" deep
- Lifetime warranty on housing, one year limited on all other parts
- Size: 50" high, 18" wide, 31" deep
- Optional stand (sold separately)
- Crusher weight 404 lbs. with stand 516 lbs. (shipping weight 576 lbs.\ trucked on pallet.)

New Crushers

MODEL NO.	DESCRIPTION	SHIPPING WEIGHT LBS (KG)
008215	TT25 Electric Hydraulic Oil Filter Crusher, 60Hz	464 (210.5)
007550	Large Crusher Stand with Reservoir for C-6, TT12 and TT25 Oil Filter Crushers	172 (78)
007720	TT25 Electric Hydraulic Oil Filter Crusher (008215) with Crusher Stand with Reservoir (007550)	576 (261.3)



Model 007550

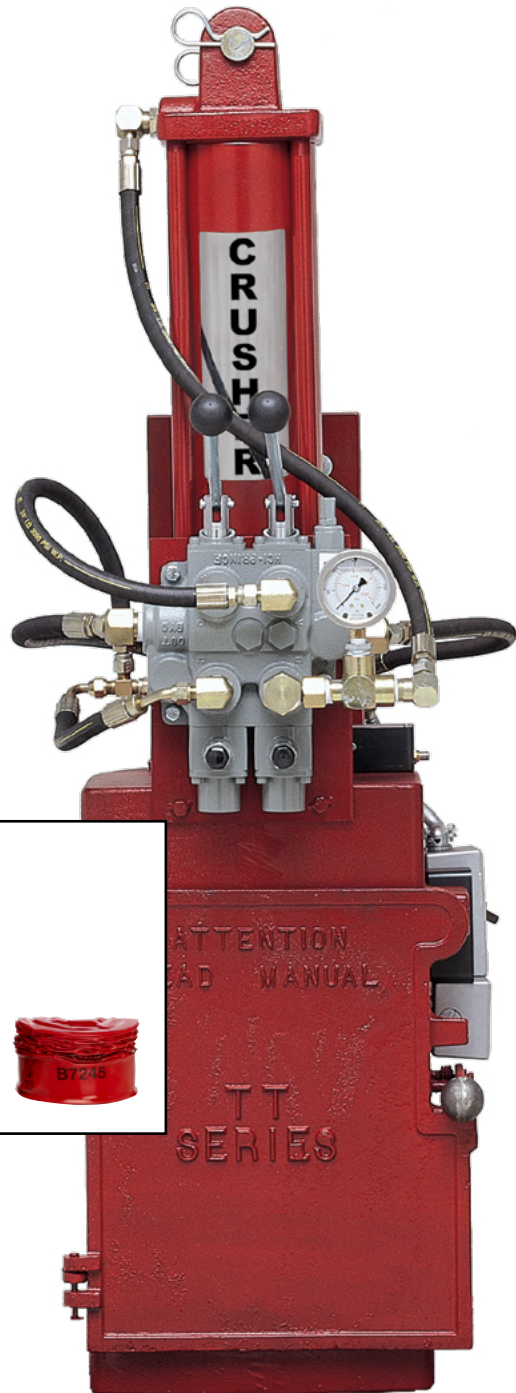

Model 008215



 WARNING: Cancer and Reproductive Harm - www.P65Warnings.ca.gov

TT-25 Crusher

Electric Hydraulic Oil Filter Crusher for tractor trailer and truck filters.

Dimensions and System Options

Repair Parts

MODEL NO.	DESCRIPTION
007714	TT25 9/16" MJIC x 9/16" Elbow Adaptor
007863	TT12, TT25 Push Plate
007929	TT25 Ram
007734	TT25 Pump, 60Hz
011943	TT25 Pump, 50Hz
007899	TT25 Handle Spring
007904	C4, C6, TT12, TT25 3/8" Ball Bearing Switch
007905	C4, C6, TT12, TT25 Safety Switch Spring
007906	C4, C6, TT12, TT25 1/4" x 2-1/4" Clevis Pin
007907	C4, C6, TT12, TT25 3/8" ID x 1/2" OD Bearing
007908	C4, C6, TT12, TT25 1/4" x 1-1/2" Clevis Pin
007909	C4, C6, TT12, TT25 3/32" x 1/2" Cotter Pin
007917	C4, C6, TT12, TT25 3/8" x 2-1/4" Grade 8 Tap Bolt
007918	C4, C6, TT12, TT25 3/8" x 16 Stover Nut
007938	C4, C6, TT12, TT25 5/16" Flat Washer

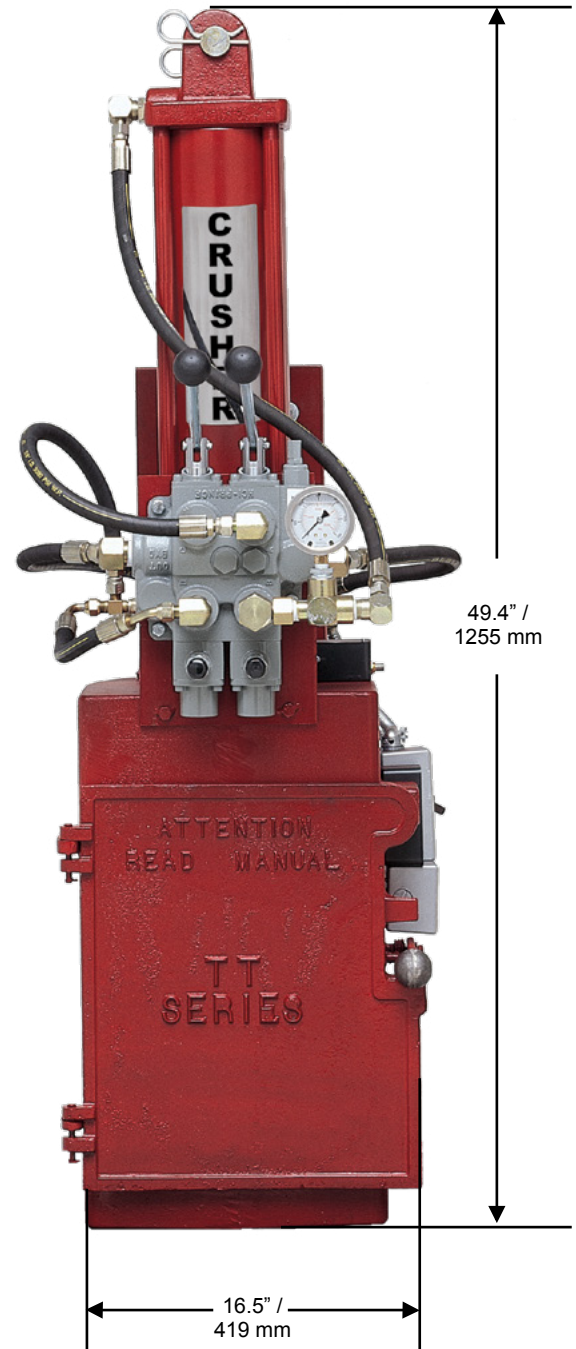

Rev 6 6/22

Filter Crusher Stands

For all truck and automotive filter crushers.

Model 007550

- Industrial grade steel
- Drain shelf for storing filters
- 2" NPT drain for piping to other storage vessels
- Accommodates a 30-gallon drum
- Can be used with most filter crushers manufactured by BJ Enterprises
- Vibration pads and provisions for securing to the floor

Model 007590

- Designed for use with C-4 and C-6 oil filter crushers
- Industrial grade steel
- Vibration pads and provisions for securing to the floor

New Stands

MODEL NO.	DESCRIPTION	SHIPPING WEIGHT LBS (KG)
007550	Large Crusher Stand with Reservoir for C-6, TT12 and TT25 Oil Filter Crushers	153 (69.4)
007590	Small Crusher Stand for C-4 and C-6 Oil Filter Crushers	101 (45.9)



 WARNING: Cancer and Reproductive Harm - www.P65Warnings.ca.gov

Filter Crusher Stands

For all truck and automotive filter crushers.

Dimensions and System Options

Automotive Crushers

MODEL NO.	DESCRIPTION
007605	C-4 Pneumatic Automobile Oil Filter Crusher
008203	C-4 Pneumatic Automobile Oil Filter Crusher with #007590 Crusher Stand
008207	C-6 Pneumatic SUV Oil Filter Crusher
007610	C-6 Pneumatic SUV Oil Filter Crusher with #007590 Crusher Stand

Truck Crushers

MODEL NO.	DESCRIPTION
007715	TT12 Pneumatic Truck Oil Filter Crusher
008210	TT12 Pneumatic Truck Oil Filter Crusher with #007550 Crusher Stand with Reservoir
008215	TT25 Electronic Over Hydraulic Oil Filter Crusher
007720	TT25 Electronic Over Hydraulic Oil Filter Crusher with #007550 Crusher Stand with Reservoir



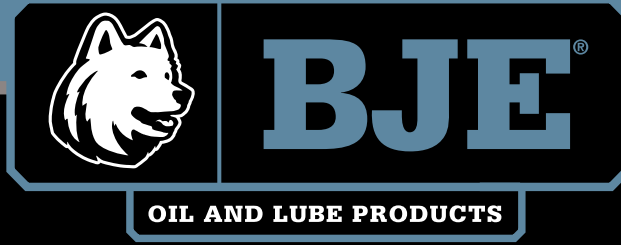

Tank Gauges

Black Knight® LLG

Numbers decrease as fluid level lowers indicating how many inches are left until the tank is empty.
For use with oil, waste oil, diesel fuel, antifreeze, and other fluids with a high flash point.

- One gauge accommodates tanks up to 99"
- Measures from 99" - 0"
- 2" NPT threads
- Large number display
- Molded housing
- Direct drive
- Nickel-plated brass chain
- Oversized aluminum float assembly rotates to prevent chain entanglement
- For use with oil, waste oil, diesel fuel, antifreeze, and most liquids with a high flash point
- New swivel allows easy orientation of gauge after installation

New Gauges

MODEL NO.	DESCRIPTION	SHIPPING WEIGHT LBS (KG)
007600	Black Knight® 99" Liquid Level Gauge for New Product	3.5 (1.6)
008164	Black Knight® 99" Liquid Level Gauge for New Product with Vertical Float	3.5 (1.6)



⚠ WARNING: Cancer and Reproductive Harm - www.P65Warnings.ca.gov

Black Knight[®] LLG

Numbers decrease as fluid level lowers indicating how many inches are left until the tank is empty. For use with oil, waste oil, diesel fuel, antifreeze, and other fluids with a high flash point.

Dimensions and System Options

Floats

MODEL NO.	DESCRIPTION
007615	1 1/2" Vertical Float
007616	2" Horizontal Float

Other Accessories

MODEL NO.	DESCRIPTION
007551	Chain, #2 Ball
007552	Eyelet, Brass
007639	Clear Acrylic Cover

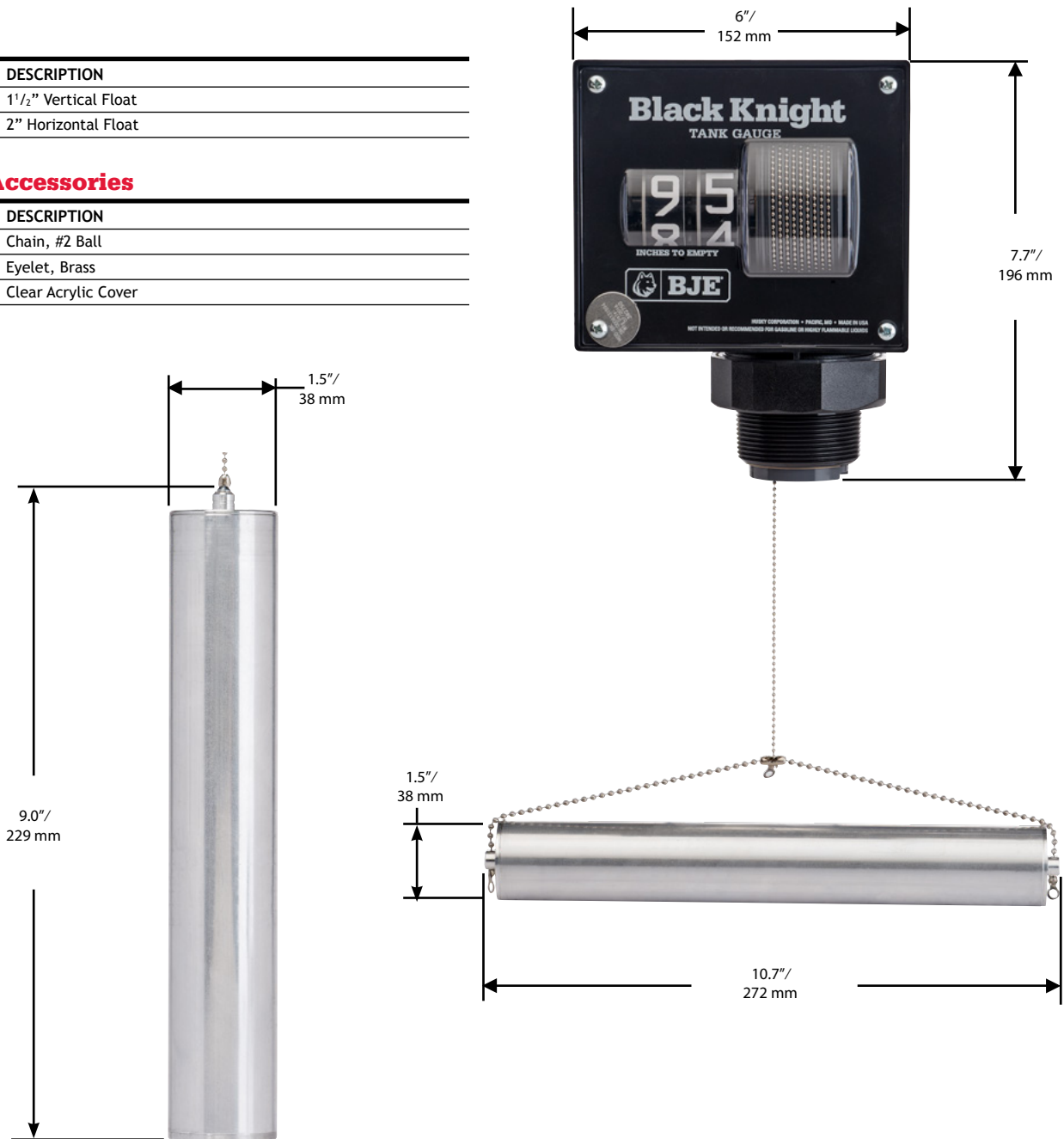

Metric Black Knight®

Numbers decrease as fluid level lowers indicating how many centimeters are left until the tank is empty. For use with oil, waste oil, diesel fuel, antifreeze, and other fluids with a high flash point.

- Large number display
- Measures from 0 cm to 365 cm (approximately 3.65 m).
- Mechanical operation, no batteries required
- Weather resistant durable molded housing
- 2" NPT threads and 2" BSPT threads
- Nickel-plated brass chain
- Aluminum horizontal float (vertical float optional)
- Easy-to-read digital readout
- Durable direct drive chain
- Less expensive than comparable models
- Faster than sticking the tank for level reading

New Gauges

MODEL NO.	DESCRIPTION	SHIPPING WEIGHT LBS (KG)
008743	Metric Black Knight® Horizontal Float, 2" BSPT	2.5 (1.1)
010176	Metric Black Knight® Horizontal Float, 2" NPT	2.5 (1.1)
010753	Metric Black Knight® Vertical Float, 2" NPT	2.5 (1.1)



WARNING: Cancer and Reproductive Harm - www.P65Warnings.ca.gov

Metric Black Knight®

Numbers decrease as fluid level lowers indicating how many centimeters are left until the tank is empty. For use with oil, waste oil, diesel fuel, antifreeze, and other fluids with a high flash point.

Dimensions and System Options

Floats

MODEL NO.	DESCRIPTION
007615	1½" Vertical Float
007616	2" Horizontal Float

Other Accessories

MODEL NO.	DESCRIPTION
007551	Chain, #2 Ball
007552	Eyelet, Brass

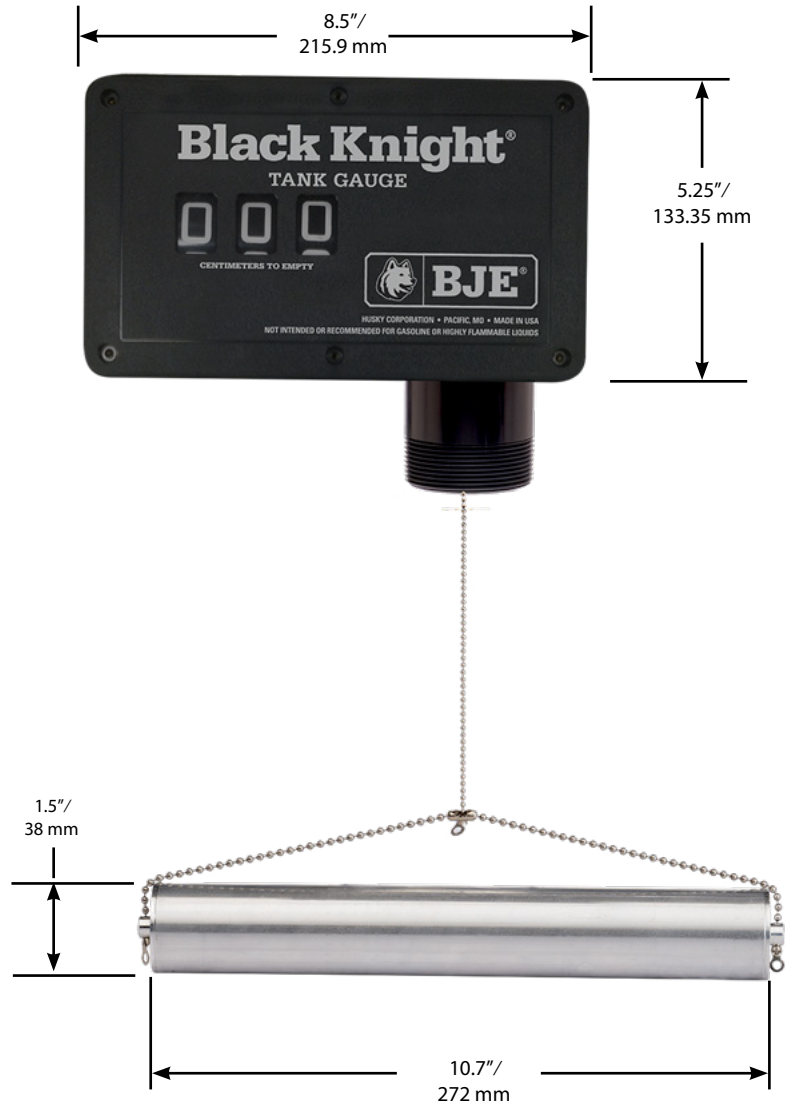
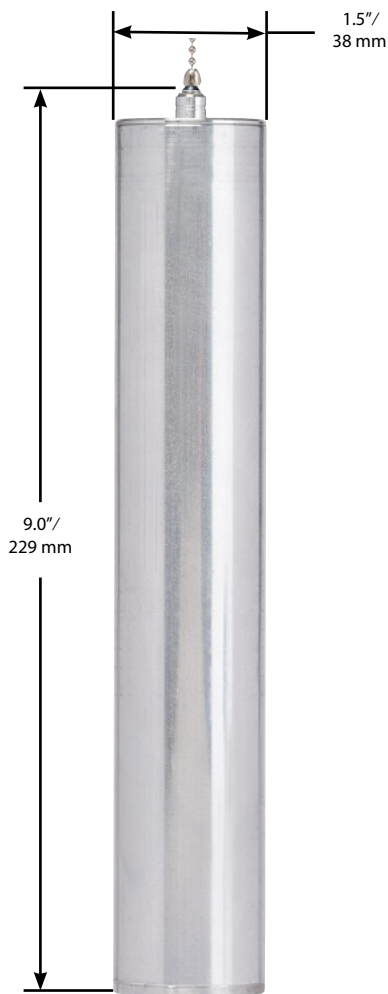

Numbers decrease as fluid level rises indicating how many inches are left until the tank is full.
 For use with oil, waste oil, diesel fuel, antifreeze, and other fluids with a high flash point.

- One gauge accommodates tanks up to 99"
- Large number display
- Molded housing
- Direct drive
- 2" NPT threads
- Nickel-plated brass chain
- Oversized aluminum float assembly rotates to prevent chain entanglement.
- For use with oil, waste oil, diesel fuel, antifreeze, and most liquids with a high flash point
- New swivel allows easy orientation of gauge after installation

New Gauges

MODEL NO.	DESCRIPTION	SHIPPING WEIGHT LBS (KG)
007665	Red Fox [®] 99" Liquid Level Gauge Horizontal Float	3.5 (1.6)
008566	Red Fox [®] 99" Liquid Level Gauge Vertical Float 2" NPT	3.5 (1.6)

*Specify tank depth (in inches) and riser height (in inches)



! WARNING: Cancer and Reproductive Harm - www.P65Warnings.ca.gov

Red Fox[®] LLG

Numbers decrease as fluid level rises indicating how many inches are left until the tank is full.
 For use with oil, waste oil, diesel fuel, antifreeze, and other fluids with a high flash point.

Dimensions and System Options

Floats

MODEL NO.	DESCRIPTION
007615	1 1/2" Vertical Float
007616	2" Horizontal Float

Other Accessories

MODEL NO.	DESCRIPTION
007551	Chain, #2 Ball
007552	Eyelet, Brass
007639	Clear Acrylic Cover

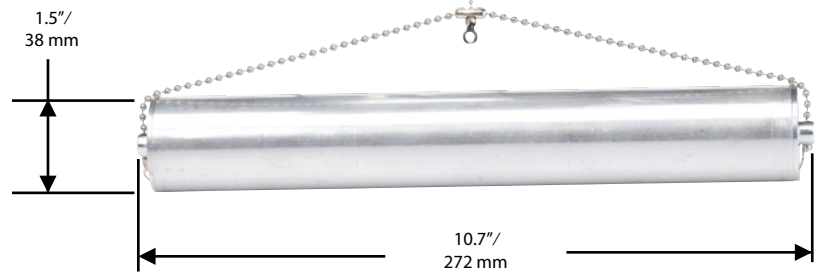
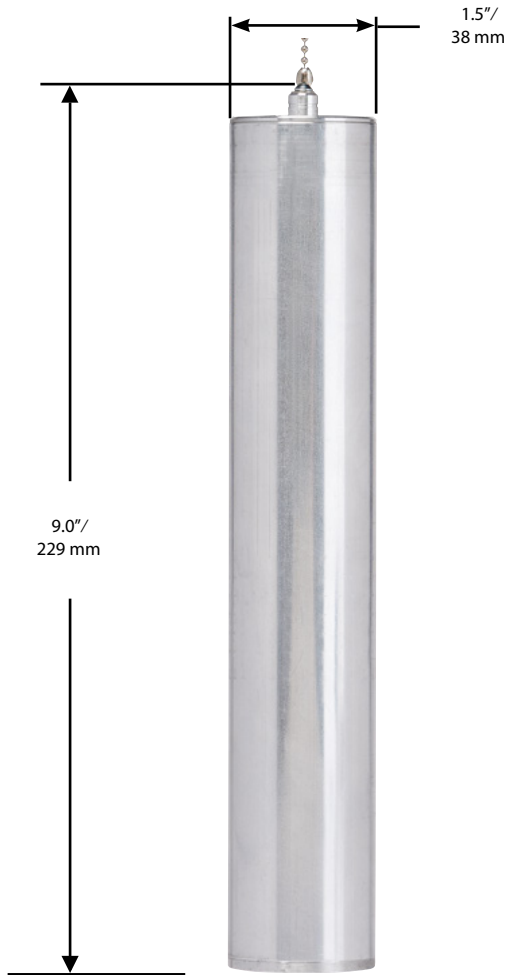

Metric Red Fox®

Liquid Level Gauges – numbers decrease as fluid level rises indicating how many centimeters are left until the tank is full. For use with oil, waste oil, diesel fuel, antifreeze, and other fluids with a high flash point.

- One gauge accommodates tanks up to 365 cm
- Large number display
- Mechanical operation, no batteries required
- Weather resistant durable molded housing
- 2" NPT threads and 2" BSPT threads
- Nickel-plated brass chain
- Easy-to-read digital readout
- Durable direct drive chain
- Less expensive than comparable models
- Faster than sticking the tank for level reading
- Aluminum horizontal float (vertical float optional)

New Gauges

MODEL NO.	DESCRIPTION	SHIPPING WEIGHT LBS (KG)
010751	Metric Red Fox® Tank Gauge, BSPT	2.5 (1.1)
010752	Metric Red Fox® Vertical, BSPT	2.5 (1.1)
010754	Metric Red Fox® Tank Gauge, NPT	2.5 (1.1)
010755	Metric Red Fox® Vertical, NPT	2.5 (1.1)



 WARNING: Cancer and Reproductive Harm - www.P65Warnings.ca.gov

Metric Red Fox[®]

Liquid Level Gauges – numbers decrease as fluid level rises indicating how many centimeters are left until the tank is full. For use with oil, waste oil, diesel fuel, antifreeze, and other fluids with a high flash point.

Dimensions and System Options

Floats

MODEL NO.	DESCRIPTION
007615	1 1/2" Vertical Float
007616	2" Horizontal Float

Other Accessories

MODEL NO.	DESCRIPTION
007551	Chain, #2 Ball
007552	Eyelet, Brass

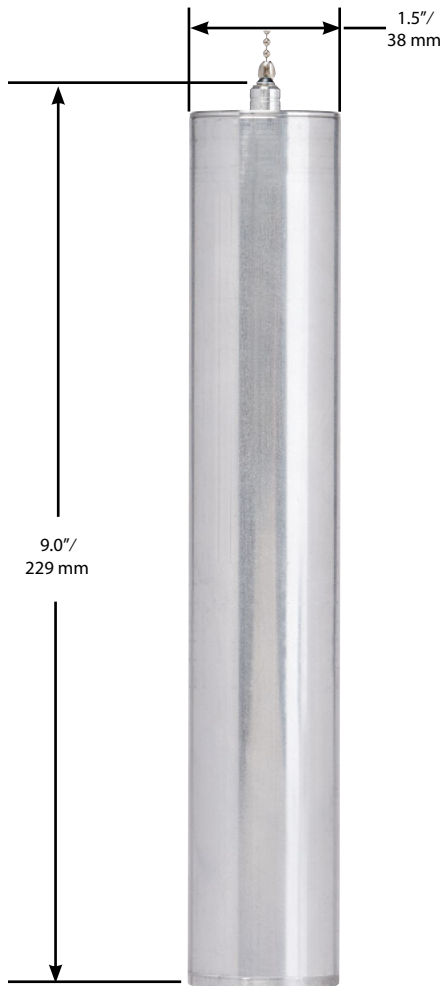

Jarhead Tank Gauge

For use with oil, waste oil, diesel fuel, antifreeze, water and other fluids with a high flash point.

- Large glass 4 window display
- Highly visible orange indicator with UV inhibitor
- 2" NPT (1-1/2" optional)
- Stainless steel rods
- Aluminum linkage
- Nitrophenyl float
- Easy installation.



New Gauges

MODEL NO.	DESCRIPTION	SHIPPING WEIGHT LBS (KG)
007620*	Jarhead Sightglass Tank Gauge with Fractional Indicators for 18"-60" Tank Depth with 2" Tank Fitting	2.0 (0.9)
007621*	Jarhead Sightglass Tank Gauge with Fractional Indicators for 18"-60" Tank Depth with 1 1/2" Tank Fitting	2.0 (0.9)
007622*	Jarhead Sightglass Tank Gauge with Fractional Indicators for 61"-72" Tank Depth with 2" Tank Fitting	2.3 (1.0)
007623*	Jarhead Sightglass Tank Gauge with Fractional Indicators for 61"-72" Tank Depth with 1 1/2" Tank Fitting	2.3 (1.0)
007625*	Jarhead 275 Gallon Sightglass Tank Gauge with 2" Tank Fitting	2.0 (0.9)
007626*	Jarhead 275 Gallon Sightglass Tank Gauge with 1 1/2" Tank Fitting	2.0 (0.9)

*Specify tank depth (in inches) and **riser height (in inches)



WARNING: Cancer and Reproductive Harm - www.P65Warnings.ca.gov

Jarhead Tank Gauge

For use with oil, waste oil, diesel fuel, antifreeze, water and other fluids with a high flash point.

Dimensions and System Options

007 Tank Monitors

MODEL NO.	DESCRIPTION
007555*	007 Audible and Visual Tank Monitor with Jarhead Tank Gauge (includes indoor mount control panel, Jarhead Tank Gauge, 2" NPT tank fitting and 12 volt transformer)
009919	007 Audible and Visual Tank Monitor with Jarhead Tank Gauge (includes indoor mount control panel, Jarhead Tank Gauge, 1-1/2" NPT tank fitting and 12 volt transformer)

Sentry Wall Mounted Tank Monitors

MODEL NO.	DESCRIPTION
007685*	Sentry High or Low Wall Mounted Battery Operated Tank Monitor with Built-in 103 Decibel Siren and Jarhead Tank Gauge, 2" NPT tank fitting
007686*	Sentry High or Low Wall Mounted Tank Monitor with Built-in 103 Decibel Siren, Jarhead Tank Gauge, 2" NPT tank fitting and 12 Volt Transformer
009969*	Sentry High or Low Wall Mounted Battery Operated Tank Monitor with Built-in 103 Decibel Siren and Jarhead Tank Gauge, 1-1/2" NPT tank fitting
009972*	Sentry High or Low Wall Mounted Tank Monitor with Built-in 103 Decibel Siren, Jarhead Tank Gauge, 1-1/2" NPT tank fitting and 12 Volt Transformer

*Specify tank depth (in inches) and **riser height (in inches)

Accessories

MODEL NO.	DESCRIPTION
011426	2" Jarhead Adaptor
007829	1-1/2" Jarhead Adaptor
007692	Jarhead Jar

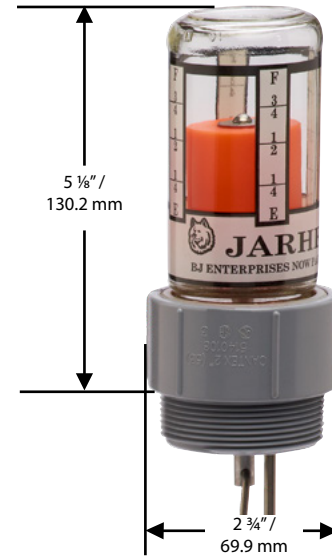

JAR Adjustable Jarhead

For use with oil, waste oil, diesel fuel, antifreeze and other fluids with a high flash point. Adjustable Jarhead that covers range of 18"-72" (46 cm - 182 cm).

- Infinitely adjustable within size range
- Durable glass housing
- Highly visible orange indicator
- Available with 2" NPT, 1 1/2" NPT, 2" BSP, and 1 1/2" BSP
- 4 ranges of tank depth available: 18"-23", 24"-34", 33"-47", 46"-72", 46 cm-58 cm, 61 cm-86 cm, 84 cm-119 cm, 117 cm-182 cm
- Scale reading - F-3/4-1/2-1/4-E
- Only mechanical tank gauge that is adjustable by the customer
- No need for custom factory orders, four models cover range of 18"-72" (46 cm-182cm)
- No special skills necessary to install
- Brass linkages
- Allen wrenches included to adjust and tighten linkages
- Aluminum float

New Adjustable Jarhead

MODEL NO.	DESCRIPTION	SHIPPING WEIGHT LBS (KG)
009909	Adjustable Jarhead, 2" NPT 18"-23"	2.0 (0.9)
009916	Adjustable Jarhead, 2" NPT 24"-34"	2.0 (0.9)
009918	Adjustable Jarhead, 2" NPT 33"-47"	2.3 (1.0)
009930	Adjustable Jarhead, 2" NPT 46"-72"	2.5 (1.1)
010393	Adjustable Jarhead, 2" BSP 46 cm-58 cm	2.0 (0.9)
010472	Adjustable Jarhead, 2" BSP 61 cm-86 cm	2.0 (0.9)
010473	Adjustable Jarhead, 2" BSP 84 cm-119 cm	2.3 (1.0)
010474	Adjustable Jarhead, 2" BSP 117 cm-182 cm	2.5 (1.1)
010996	Adjustable Jarhead, 1-1/2" NPT 18"-23"	2.0 (0.9)
010997	Adjustable Jarhead, 1-1/2" NPT 24"-34"	2.0 (0.9)
010998	Adjustable Jarhead, 1-1/2" NPT 33"-47"	2.3 (1.0)
010999	Adjustable Jarhead, 1-1/2" NPT 46"-72"	2.5 (1.1)
013638	Adjustable Jarhead, 1-1/2" BSP 84 cm-119 cm	2.3 (1.0)



 WARNING: Cancer and Reproductive Harm - www.P65Warnings.ca.gov

JAR Adjustable Jarhead

For use with oil, waste oil, diesel fuel, antifreeze and other fluids with a high flash point. Adjustable Jarhead that covers range of 18"-72" (46 cm - 182 cm).

Dimensions and System Options

Accessories

Model No.	Description
007551	#2 Ball Chain
007552	Eyelet, Brass
007692	Jarhead Jar
007829	Adaptor, 1-1/2" NPT
010009	Adaptor, 2" BSP
011189	Adaptor, 1-1/2" BSP
011426	Adaptor, 2" NPT

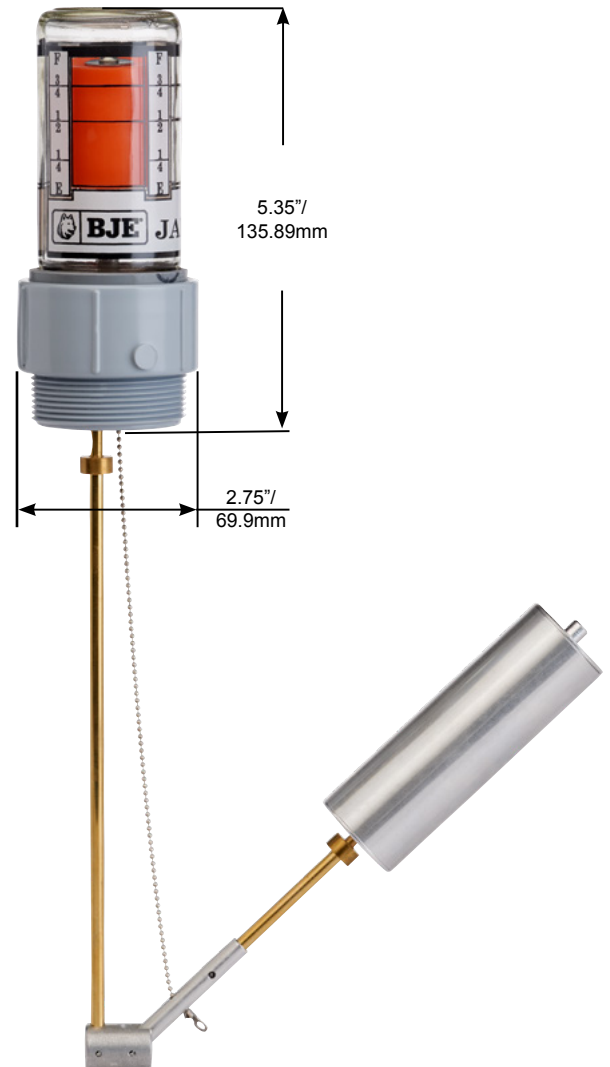

Overfill Tank Gauge

For use with oil, waste oil, diesel fuel, antifreeze and other fluids with a high flash point.



- Large glass 4 window display
- Highly visible orange indicator with UV inhibitor
- 2" NPT and BSP
- 1-1/2" NPT and BSP
- Nickel-plated brass chain, field adjustable to 24" from top of tank (extended chain available)
- Aluminum float

New Gauges

MODEL NO.	DESCRIPTION	SHIPPING WEIGHT LBS (KG)
007640*	Overfill Guard Sightglass Gauge with 2" NPT Tank Fitting	1.5 (0.7)
007641*	Overfill Guard Sightglass Gauge with 1-1/2" NPT Tank Fitting	1.5 (0.7)
011179*	Overfill Guard Sightglass Gauge with 2" BSP Tank Fitting	1.5 (0.7)
011180*	Overfill Guard Sightglass Gauge with 1-1/2" BSP Tank Fitting	1.5 (0.7)

*Specify tank depth (in inches) and **riser height (in inches)



 WARNING: Cancer and Reproductive Harm - www.P65Warnings.ca.gov

Overfill Tank Gauge

For use with oil, waste oil, diesel fuel, antifreeze and other fluids with a high flash point.

Dimensions and System Options

007 Tank Monitors

MODEL NO.	DESCRIPTION
007565	007 Audible and Visual Tank Monitor with Overfill Tank Gauge (includes indoor mount control panel, Overfill Tank Gauge and 12 volt transformer)
009965	007 Audible and Visual Tank Monitor with Overfill Tank Gauge, 1-1/2" NPT tank fitting (includes indoor mount control panel, Overfill Tank Gauge and 12 volt transformer)

Sentry Wall Mounted Tank Monitors

MODEL NO.	DESCRIPTION
007680	Sentry High or Low Wall Mounted Battery Operated Tank Monitor with Built-in 103 Decibel Siren and Overfill Tank Gauge
007681	Sentry High or Low Wall Mounted Tank Monitor with Built-in 103 Decibel Siren, Overfill Tank Gauge and 12 Volt Transformer
009973	Sentry High or Low Wall Mounted Battery Operated Tank Monitor with Built in 103 Decibel Siren, and Overfill Tank Gauge, 1-1/2" NPT tank fitting
009975	Sentry High or Low Wall Mounted Tank Monitor with Built-in 103 Decibel Siren, Overfill Tank Gauge and 12 Volt Transformer, 1-1/2" NPT tank fitting

Accessories

MODEL NO.	DESCRIPTION
007829	Adaptor, 1-1/2"
011426	Adaptor, 2"
007551	Chain, #2 Ball
007552	Eyelet, Brass
007866	Jar, Overfill



Leak Guard Tank Gauge

For use with oil, waste oil, diesel fuel, antifreeze and other fluids with a high flash point.



- Large glass 4 window display
- Highly visible orange indicator with UV inhibitor
- 2" NPT and BSP
- 1-1/2" NPT and BSP
- Nickel-plated brass chain. Field adjustable to 72" from top of tank (Model No. 010002 and 014287 have 120" extended chain available)
- Aluminum float

New Gauges

MODEL NO.	DESCRIPTION	SHIPPING WEIGHT LBS (KG)
007635	Leak Guard Sightglass Gauge for Double Wall Tanks with 2" Male NPT Tank Fitting	1.5 (0.7)
007636	Leak Guard Sightglass Gauge for Double Wall Tanks with 1 1/2" Male NPT Tank Fitting	1.5 (0.7)
010002	Leak Guard Sightglass Gauge for Double Wall Tanks with 2" Male NPT Tank Fitting and 120" Extended Chain	1.5 (0.7)
011177	Leak Guard Sightglass Gauge for Double Wall Tanks with 2" Male BSP Tank Fitting	1.5 (0.7)
011178	Leak Guard Sightglass Gauge for Double Wall Tanks with 1 1/2" Male BSP Tank Fitting	1.5 (0.7)
014287	Leak Guard Sightglass Gauge for Double Wall Tanks with 1 1/2" Male NPT Tank Fitting and 120" Extended Chain	1.5 (0.7)
014556	Leak Guard Sightglass Gauge for Double Wall Tanks with 2" Female NPT Tank Fitting	1.5 (0.7)



Leak Guard Tank Gauge

For use with oil, waste oil, diesel fuel, antifreeze and other fluids with a high flash point.

Dimensions and System Options

007 Tank Monitors

MODEL NO.	DESCRIPTION
007560	007 Audible and Visual Tank Monitor with Leak Guard Tank Gauge (includes indoor mount control panel, Leak Guard Tank Gauge and 12 volt transformer)

Sentry Wall Mounted Tank Monitors

MODEL NO.	DESCRIPTION
007675	Sentry High or Low Wall Mounted Battery Operated Tank Monitor with Built-in 103 Decibel Siren and Leak Guard Tank Gauge
007676	Sentry High or Low Wall Mounted Tank Monitor with Built-in 103 Decibel Siren, Leak Guard Tank Gauge and 12 Volt Transformer
009967	Sentry High or Low Wall Mounted Battery Operated Tank Monitor with Built-in 103 Decibel Siren and Leak Guard Tank Gauge, 1-1/2" Male NPT tank fitting
009970	Sentry High or Low Wall Mounted Battery Operated Tank Monitor with Built-in 103 Decibel Siren, Leak Guard Tank Gauge and 12 Volt Transformer, 1-1/2" Male NPT tank fitting

Accessories

MODEL NO.	DESCRIPTION
007551	Chain, #2 Ball
007552	Eyelet, Brass
011426	Adaptor, 2"
007865	Jar, Leak



Seasee Drum Gauge

55 Gallon Horizontal Drum Gauge for use with oil, waste oil, diesel fuel, antifreeze, water and other fluids with a high flash point.



- Zinc-plated aluminum faucet
- Zinc-plated steel drum gauge with visible fluid level
- Quick disconnect gauge fitting
- Gauge can be removed during installation/removal from drum
- For most fluids except concentrated acids or bases
- Fits 55 gallon drums with $\frac{3}{4}$ " NPT bung

New Gauges

MODEL NO.	DESCRIPTION	SHIPPING WEIGHT LBS (KG)
010528	55 Gallon Horizontal Drum Gauge	2.0 (0.9)

Construction

Gauge	Clear polymer
Faucet	Aluminum/polymers
Body	Steel
Quick disconnect	Brass/steel



⚠ WARNING: Cancer and Reproductive Harm - www.P65Warnings.ca.gov

Seasee Drum Gauge

55 Gallon Horizontal Drum Gauge for use with oil, waste oil, diesel fuel, antifreeze, water and other fluids with a high flash point.

Dimensions

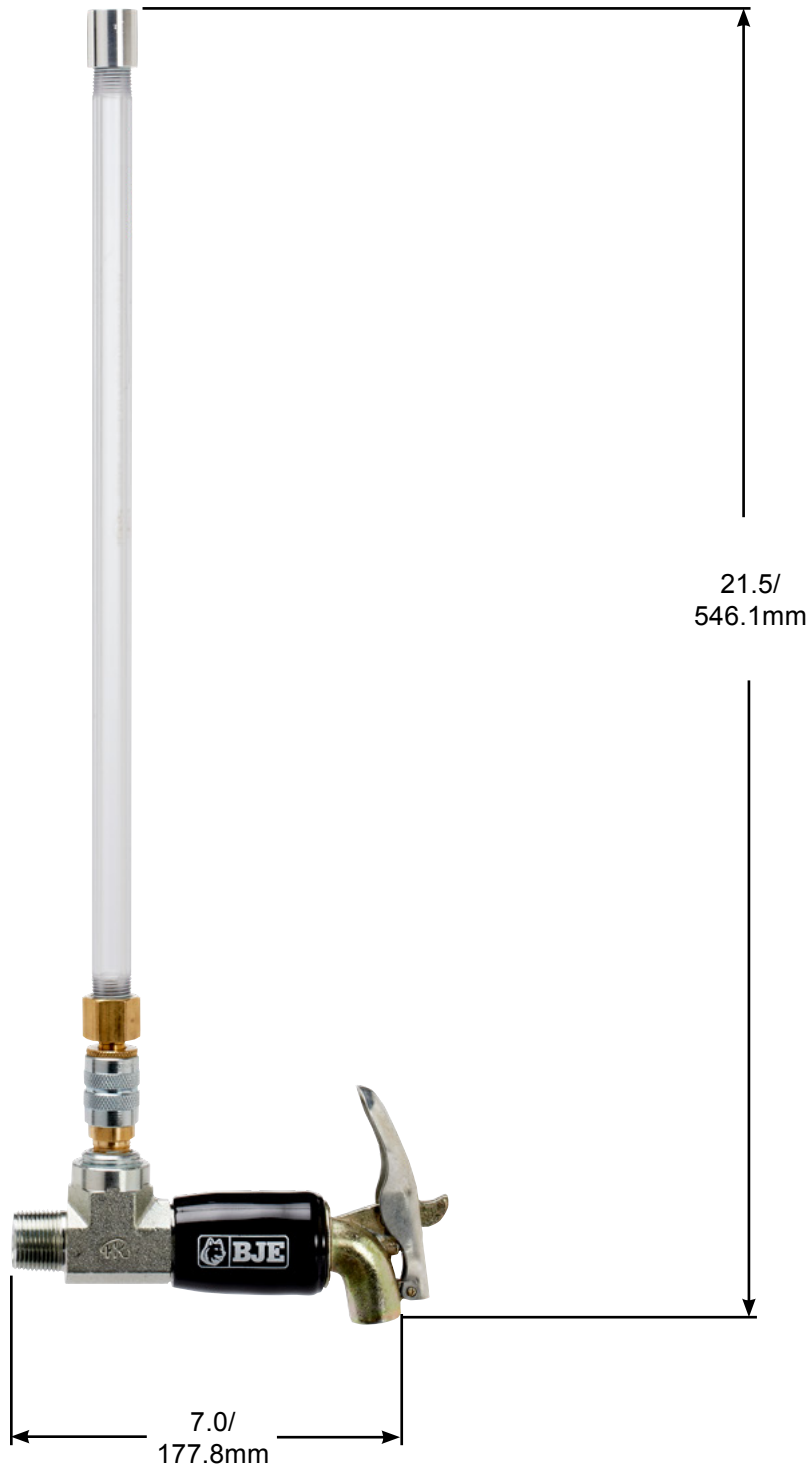

DEF Black Knight® LLG

Numbers decrease as fluid level lowers indicating how many inches are left until the tank is empty.
For use with diesel exhaust fluid (DEF).

- One gauge accommodates tanks up to 99"
- Measures from 99" - 0"
- 2" NPT threads
- Large number display
- Molded housing
- Direct drive
- Stainless steel chain
- Oversized, DEF compatible anodized aluminum float assembly rotates to prevent chain entanglement
- For use with diesel exhaust fluid (DEF)
- New swivel allows easy orientation of gauge after installation

New Gauges

MODEL NO.	DESCRIPTION	SHIPPING WEIGHT LBS (KG)
011809	DEF Black Knight® 99" Liquid Level Gauge for Diesel Exhaust Fluid	3.3 (1.5)



 WARNING: Cancer and Reproductive Harm - www.P65Warnings.ca.gov

DEF Black Knight® LLG

Numbers decrease as fluid level lowers indicating how many inches are left until the tank is empty.
For use with diesel exhaust fluid (DEF).

Dimensions and System Options

Floats

MODEL NO.	DESCRIPTION
013717	Float, DEF, 2" Horizontal, Anodized Assembly

Other Accessories

MODEL NO.	DESCRIPTION
007639	Clear Polycarbonate Cover

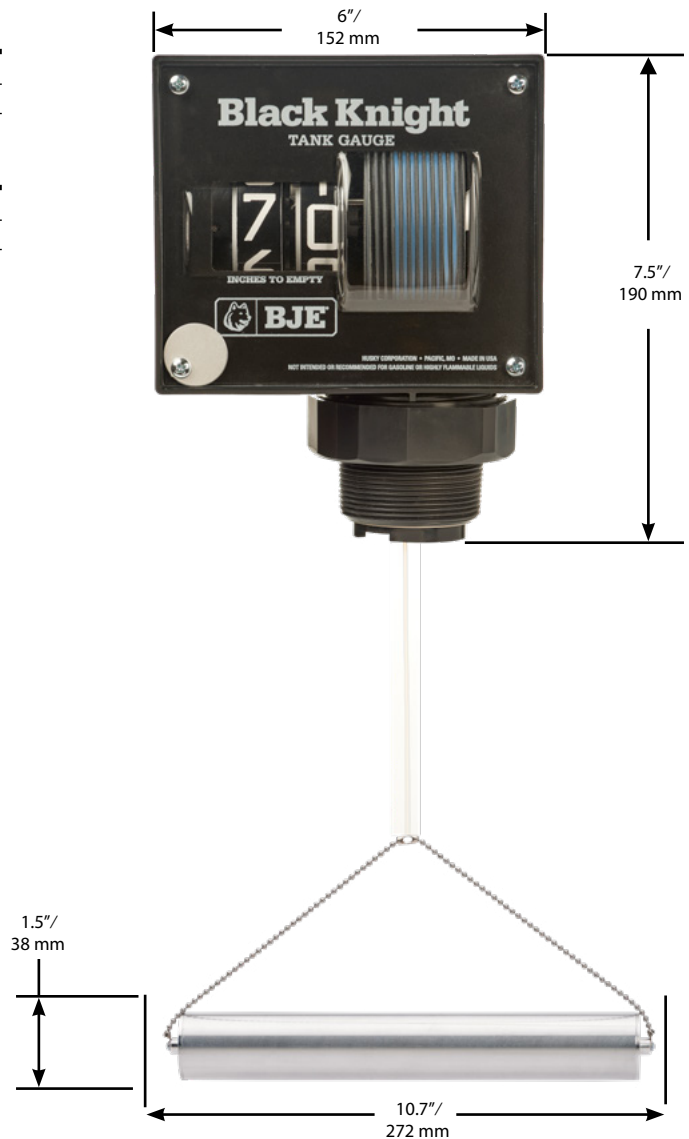

Clearly Gauge® LLG

Numbers decrease as fluid level lowers indicating how many inches are left until the tank is empty.
For use with oil, waste oil, diesel fuel, antifreeze, and other fluids with a high flash point.

- One gauge accommodates tanks up to 72"
- Measures from 72" - 0"
- 2" NPT threads
- Molded housing
- Direct drive
- Nickel-plated brass chain
- Oversized aluminum float assembly rotates to prevent chain entanglement
- For use with oil, waste oil, diesel fuel, antifreeze, and most liquids with a high flash point
- Greater depths available on request

New Gauges

MODEL NO.	DESCRIPTION	SHIPPING WEIGHT LBS (KG)
013962	Clearly Gauge® 72" Liquid Level Gauge	.95 (.43)
015184	Clearly Gauge® 72" Liquid Level Gauge with Vertical Float	.95 (.43)

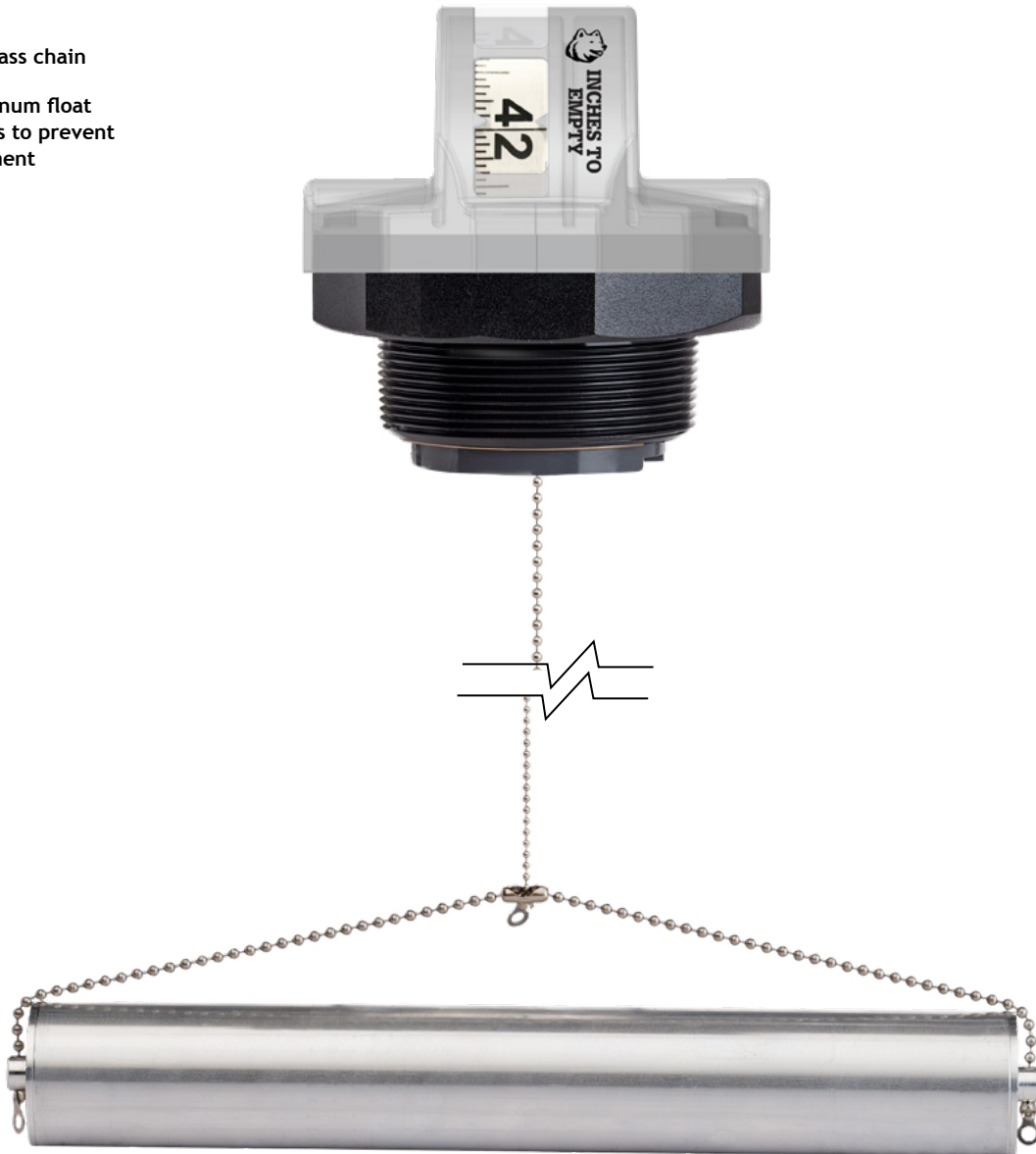

⚠️ WARNING: Cancer and Reproductive Harm - www.P65Warnings.ca.gov

Clearly Gauge® LLG

Numbers decrease as fluid level lowers indicating how many inches are left until the tank is empty.
 For use with oil, waste oil, diesel fuel, antifreeze, and other fluids with a high flash point.

Dimensions and System Options

Floats

MODEL NO.	DESCRIPTION
007615	1 1/2" Vertical Float
007616	1 1/2" Horizontal Float

Other Accessories

MODEL NO.	DESCRIPTION
007551	Chain, #2 Ball
007552	Eyelet, Brass

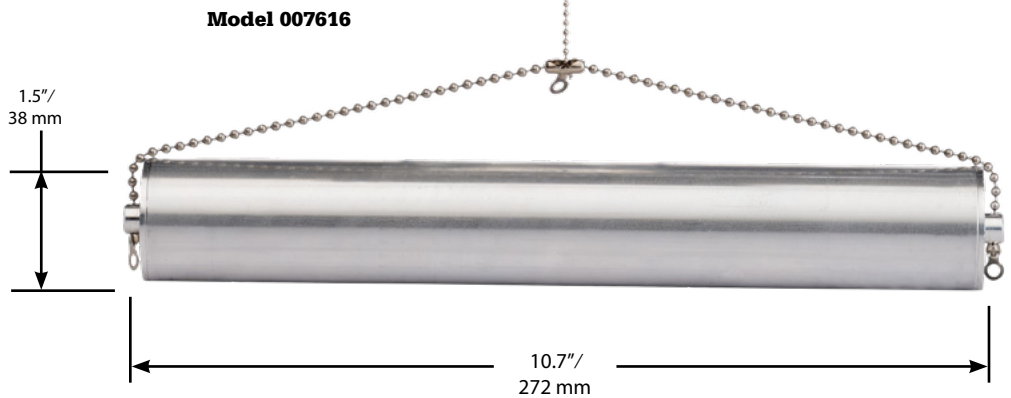
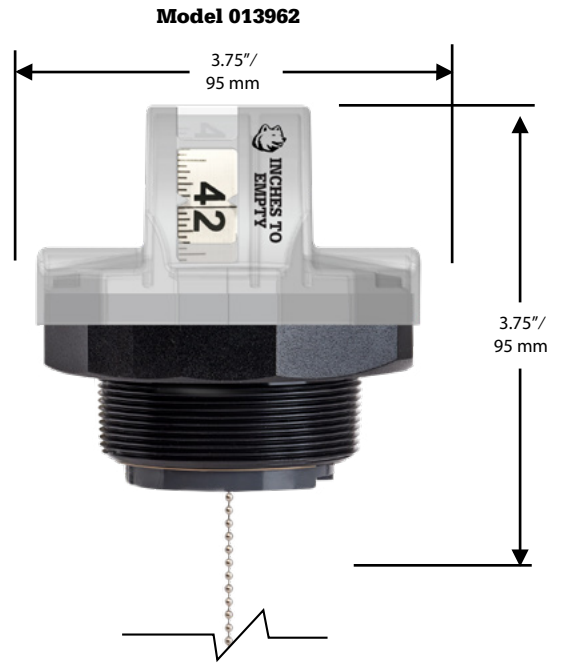
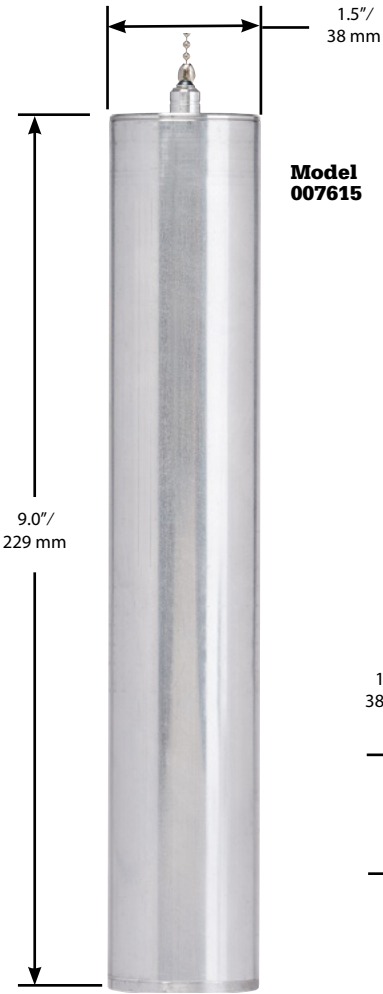

Clearly Gauge® LLG

Numbers decrease as fluid level rises indicating how many inches are left until the tank is full.
For use with oil, waste oil, diesel fuel, antifreeze, and other fluids with a high flash point.

- One gauge accommodates tanks up to 72"
- Measures from 72" - 0"
- 2" NPT threads
- Molded housing
- Direct drive
- Nickel-plated brass chain
- Oversized aluminum float assembly rotates to prevent chain entanglement
- For use with oil, waste oil, diesel fuel, antifreeze, and most liquids with a high flash point.
- Greater depths available on request

New Gauges

MODEL NO.	DESCRIPTION	SHIPPING WEIGHT LBS (KG)
016010	Clearly Gauge® 72" Liquid Level Gauge	.95 (.43)



⚠️ WARNING: Cancer and Reproductive Harm - www.P65Warnings.ca.gov

Clearly Gauge® LLG

Numbers decrease as fluid level rises indicating how many inches are left until the tank is full.
 For use with oil, waste oil, diesel fuel, antifreeze, and other fluids with a high flash point.

Dimensions and System Options

Floats

MODEL NO.	DESCRIPTION
007615	1 1/2" Vertical Float
007616	1 1/2" Horizontal Float

Other Accessories

MODEL NO.	DESCRIPTION
007551	Chain, #2 Ball
007552	Eyelet, Brass

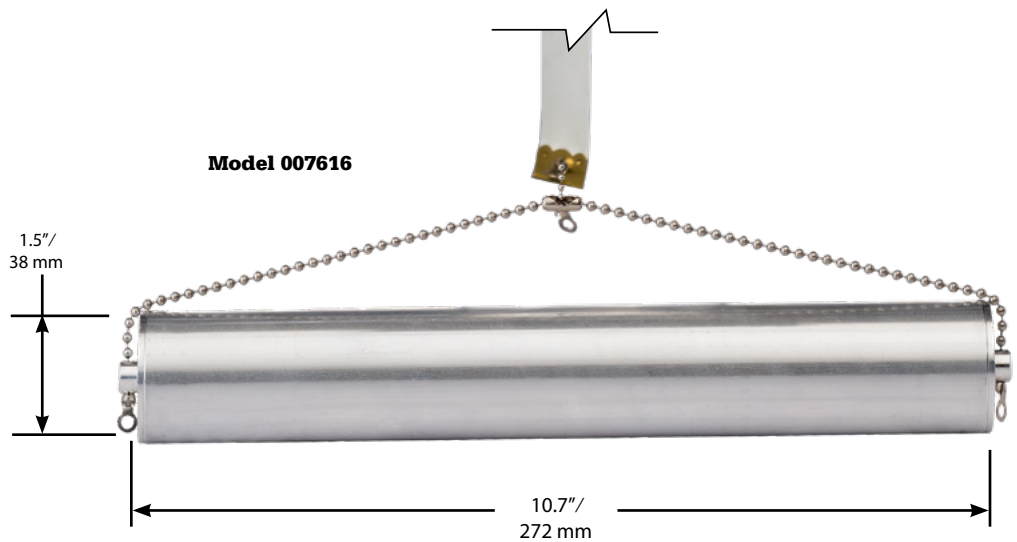
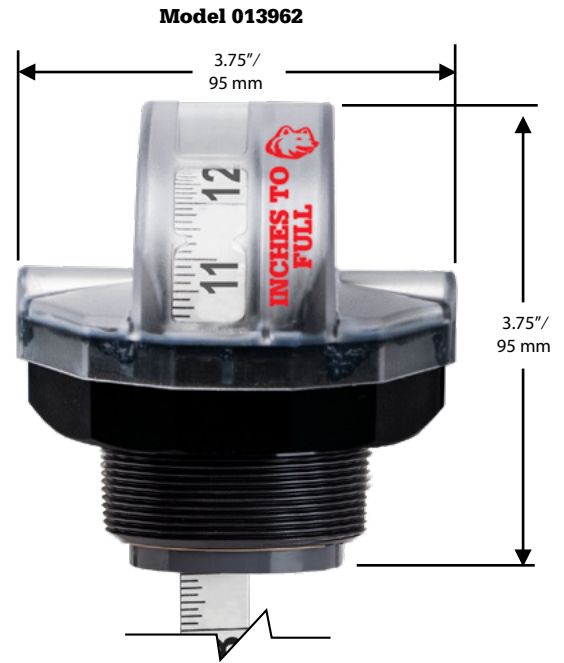
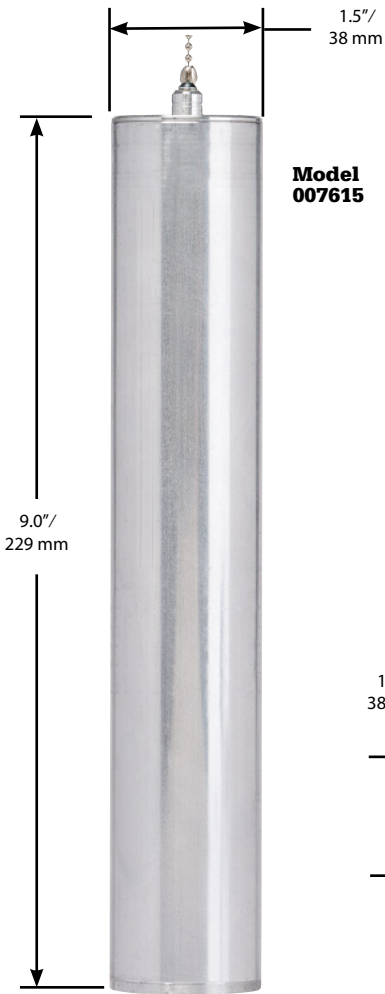

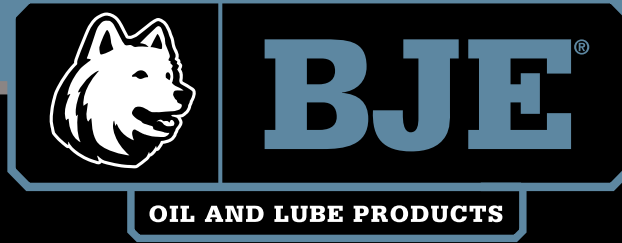

Tank Gauges and Alarms

007 Tank Alarm

High/Low Tank Alarm for use with oil, waste oil, diesel fuel, antifreeze, water and other fluids with a high flash point.

- Avoid costly overflows or untimely shortages
- Supervised system
- Low voltage
- Strobe and siren
- Can drive up to 10 solenoid valves
- Easy installation
- Maximum milliamp load is 750 mA, do not exceed

New Gauges and Alarms

MODEL NO.	DESCRIPTION	SHIPPING WEIGHT LBS (KG)
007575	007 Audible and Visual Tank Gauge (includes indoor mount control panel, remote tank sensor, 10' lead wire and 12 volt transformer)	4.0 (1.8)
007555*	007 Audible and Visual Tank Gauge with Jarhead Tank Gauge (includes indoor mount control panel, Jarhead Tank Gauge, and 12 volt transformer) with 2" NPT Tank Fitting	5.0 (2.3)
007560	007 Audible and Visual Tank Gauge with Leak Guard Tank Gauge (includes indoor mount control panel, Leak Guard tank gauge and 12 volt transformer) with 2" NPT Tank Fitting	5.0 (2.3)
009963	007 Audible and Visual Tank Gauge with Overfill Tank Gauge (includes indoor mount control panel, Overfill tank gauge and 12 volt transformer) with 1-1/2" NPT Tank Fitting	5.0 (2.3)
007565**	007 Audible and Visual Tank Gauge with 2" NPT Tank Fitting	5.0 (2.3)
009965**	007 Audible and Visual Tank Gauge with 1-1/2" NPT Tank Fitting	5.0 (2.3)
008295	Audible and Visual Tank Monitor with 12 volt transformer (does not include a tank sensor)	5.0 (2.3)
010304	007 Tank Alarm with built-in 103 Decibel Siren and Strobe Light, Remote 55 Gallon Drum High Level Sensor and 12 volt Transformer	2.8 (1.3)
010305	007 Tank Alarm with built-in 103 Decibel Siren and Strobe Light, Remote 55 Gallon Drum Low Level Sensor with Seal and 12 volt Transformer	3.0 (1.4)
010306	007 Tank Alarm with built-in 103 Decibel Siren and Strobe Light, Remote 55 Gallon Drum High Level Sensor with Seal and 12 volt Transformer	2.8 (1.3)
011875	007 Audible and Visual Tank Gauge, 007 SV Solenoid Valve (includes indoor mount control panel, remote tank sensor, 10' lead wire, pneumatic shut off solenoid valve and two 12 volt transformers)	9.0 (4.1)

*Specify tank depth (in inches) and **riser height (in inches).



! WARNING: Cancer and Reproductive Harm - www.P65Warnings.ca.gov

007 Tank Alarm

High/Low Tank Alarm for use with oil, waste oil, diesel fuel, antifreeze, water and other fluids with a high flash point.

Dimensions and System Options

Accessories

MODEL NO.	DESCRIPTION
007595	12 volt Transformer
007660	Remote Tank Sensor
007936*	Remote Jarhead Tank Sensor with 2" tank fitting
008206*	Remote Jarhead Tank Sensor with 1-1/2" tank fitting
007655	Remote Leak Guard Tank Sensor with 2" tank fitting
007656	Remote Leak Guard Tank Sensor with 1-1/2" tank fitting
007742*	Remote Overfill Guard Tank Sensor with 2" tank fitting
007743**	Remote Overfill Guard Tank Sensor with 1-1/2" tank fitting
007695	Strobe Light
007690	Siren - 107 Decibels
007645	Heavy Duty Power Relay - 30 amp or 1-1/2" HP at 120 or 240 vac
009503	Remote 55 Gallon Drum High Level Sensor
009980	Remote 55 Gallon Drum Low Level Sealed Sensor
010000	Remote 55 Gallon Drum High Level Sealed Sensor

*Specify tank depth (in inches) and **riser height (in inches).

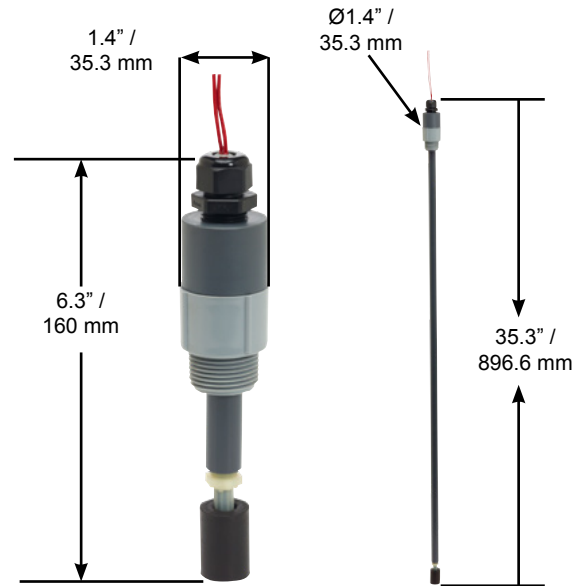

Sentry Tank Alarm

High/Low Tank Alarm for use with oil, waste oil, diesel fuel, antifreeze, water and other fluids with a high flash point.

- Avoid costly overflows or untimely inventory shortages
- Engineered for most single and double walled above ground tanks
- Common 9-volt battery operated or upgradeable to AC power
- Alarm sounds for up to four days on a fresh battery
- Ideal for remote areas where AC power is not accessible
- Simple installation; easy maintenance
- New swivel allows easy orientation of gauge after installation

New Monitors and Alarms

MODEL NO.	DESCRIPTION	SHIPPING WEIGHT LBS (KG)
007670	Sentry High or Low Battery Operated Tank Alarm with Built-in 103 Decibel Siren	2.5 (1.1)
007671	Sentry high or Low Tank Alarm with Built-in 103 Decibel Siren and 12 Volt Transformer	3.5 (1.6)



 WARNING: Cancer and Reproductive Harm - www.P65Warnings.ca.gov

Sentry Tank Alarm

High/Low Tank Alarm for use with oil, waste oil, diesel fuel, antifreeze, water and other fluids with a high flash point.

Dimensions



Sentry Wall Mount

High/Low Tank Alarm for use with oil, waste oil, diesel fuel, antifreeze, water and other fluids with a high flash point.

- Avoid costly overflows or untimely inventory shortages
- Engineered for most single and double walled aboveground tanks
- Common 9-volt battery operated or upgradeable to AC power
- Alarm sounds for up to four days on a fresh battery
- Ideal for remote areas where AC power is not accessible
- Simple installation; easy maintenance



Monitors and Alarms

MODEL NO.	DESCRIPTION	SHIPPING WEIGHT LBS (KG)
007675 x	Sentry High or Low Wall Mount Battery Operated Tank Alarm with Built-in 103 Decibel Siren and Leak Guard Tank Sensor, with 2" NPT tank fitting with 1-1/2" NPT tank fitting	4.8 (2.2)
007676	Sentry High or Low Wall Mount Battery Operated Tank Alarm with Built-in 103 Decibel Siren, Leak Guard Tank Sensor and 12 Volt Transformer, with 2" NPT tank fitting	5.5 (2.5)
007680 009973	Sentry High or Low Wall Mount Battery Operated Tank Alarm with Built-in 103 Decibel Siren and Overfill Tank Sensor, with 2" NPT tank fitting with 1-1/2" NPT tank fitting	4.0 (1.8)
007681 009975	Sentry High or Low Wall Mount Battery Operated Tank Alarm with Built-in 103 Decibel Siren, Overfill Tank Sensor, and 12 Volt Transformer, with 2" NPT tank fitting with 1-1/2" NPT tank fitting	5.5 (2.5)
007725 009964	Sentry High or Low Wall Mount Battery Operated Tank Alarm with Built-in 103 Decibel Siren, with 2" NPT tank fitting with 1-1/2" NPT tank fitting	3.0 (1.4)
007726	Sentry High or Low Wall Mount Battery Operated Tank Alarm with Built-in 103 Decibel Siren and 12 Volt Transformer, with 2" NPT tank fitting	4.0 (1.8)
007685* 009969	Sentry High or Low Wall Mount Battery Operated Tank Alarm with Built-in 103 Decibel Siren and Jarhead Tank Sensor, with 2" NPT tank fitting with 1-1/2" NPT tank fitting	5.5 (2.5)
007686* 009972	Sentry High or Low Wall Mount Battery Operated Tank Alarm with Built-in 103 Decibel Siren, Jarhead Tank Sensor, and 12 Volt Transformer, with 2" NPT tank fitting with 1-1/2" NPT tank fitting	6.5 (3.0)
010713	Sentry Wall Mount Tank Alarm with Built-in 103 Decibel Siren, Remote 55 Gallon Drum High Level Sensor and Battery	3.0 (1.4)

*Specify tank depth (in inches) and **riser height (in inches)



WARNING: Cancer and Reproductive Harm - www.P65Warnings.ca.gov

Sentry Wall Mount

High/Low Tank Alarm for use with oil, waste oil, diesel fuel, antifreeze, water and other fluids with a high flash point.

Dimensions and System Options

Sensors

MODEL NO.	DESCRIPTION
007661	Remote Tank Sensor
007650	Remote Jarhead Tank Sensor - 2" Tank Fitting
008211	Remote Jarhead Tank Sensor - 1 1/2" Tank Fitting
007657	Remote Leak Guard Tank Sensor - 2" Tank Fitting
007658	Remote Leak Guard Tank Sensor - 1 1/2" Tank Fitting
007740	Remote Overfill Guard Tank Sensor - 2" Tank Fitting
007741	Remote Overfill Guard Tank Sensor - 1 1/2" Tank Fitting
010821	Remote 55 Gallon Drum Low Level Sensor
010824	Remote 55 Gallon Drum High Level Sealed Sensor

Accessories

MODEL NO.	DESCRIPTION
007829	Adaptor, 1-1/2" NPT
007689	Adaptor, 2" NPT
007551	Chain, #2 Ball
007552	Eyelet, Brass
007606	Float Sensor
007692	Jar, Jarhead
007865	Jar, Leak
007866	Jar, Overfill

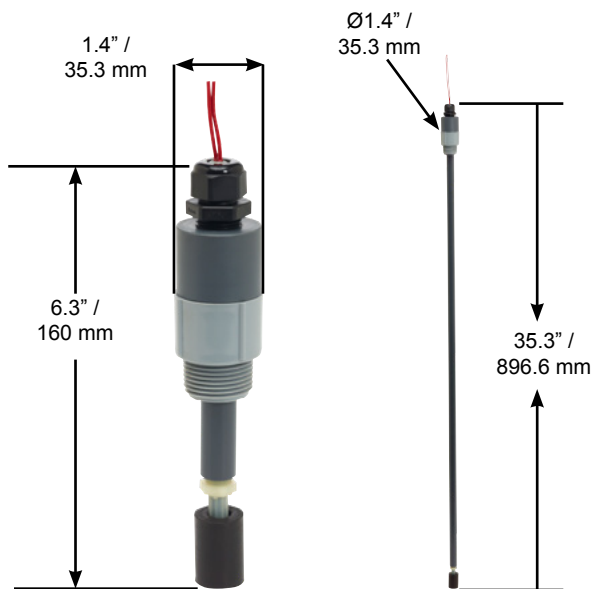
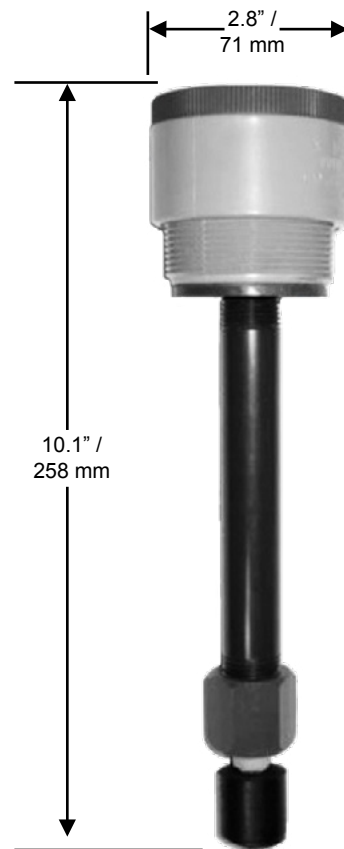
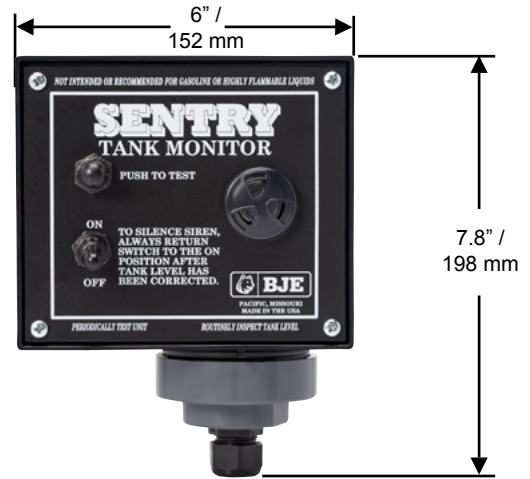

DEF Jarhead

Diesel Exhaust Fluid Tank Gauge with JARHEAD.

- Indicates level in fractions: empty - 1/4 - 1/2 - 3/4 - full
- Durable silk screen painted scales
- Constructed from materials 100% compatible with Diesel Exhaust Fluid (DEF)
- Visi-Glo® level indicator clearly displayed in the large glass window
- Available in custom lengths from 12" - 120" (457.2 - 3048 mm)
- Available for use with the 007 and Sentry high or low tank gauges



New Gauges and Alarms

MODEL NO.	DESCRIPTION	SHIPPING WEIGHT LBS (KG)
008558	Sightglass tank gauge with fractional indicators for 12" - 120" tank depth with 2" NPS connection	2.0 (0.9)
008665	Sightglass tank gauge with fractional indicators for 61" - 120" tank depth with 2" NPS connection	2.3 (1.0)

Construction

Body	Large glass housing
Rods	Stainless steel
Fasteners	Stainless steel
Connectors	Acetal
Linkage	Acetal
Float	DEF Compatible Anodized Aluminum
Seals	Fluorocarbon
Threads	2" / 50.8 mm NPS



WARNING: Cancer and Reproductive Harm - www.P65Warnings.ca.gov

DEF Jarhead

Diesel Exhaust Fluid Tank Gauge with JARHEAD.

Dimensions

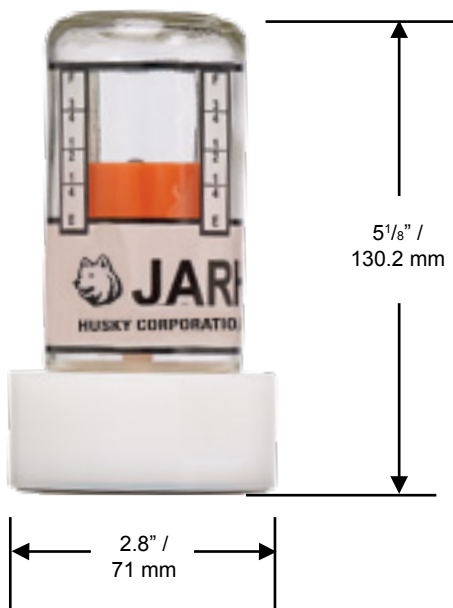

DEF Overfill Guard

Diesel Exhaust Fluid OVERFILL Guard Tank Gauge.

- Constructed from materials 100% compatible with Diesel Exhaust Fluid (DEF)
- Stainless steel, field adjustable chain up to 72" (1,828.8 mm)
- Durable silk screen printed graphics
- Visi-Glo® level indicator clearly displayed in the large glass window
- Available for use with the 007 and Sentry high or low tank alarms



New Gauges and Alarms

MODEL NO.	DESCRIPTION	SHIPPING WEIGHT LBS (KG)
008670	Sightglass overfill guard tank gauge with 2" NPS connection	1.5 (.68)

Construction

Body	Large glass housing
Chain	Stainless steel
Fasteners	Stainless steel
Connectors	Acetal
Linkage	Acetal
Float	DEF Compatible Anodized Aluminum
Seals	Fluorocarbon



 WARNING: Cancer and Reproductive Harm - www.P65Warnings.ca.gov

DEF Overfill Guard

Diesel Exhaust Fluid OVERFILL Guard Tank Gauge.

Dimensions



DEF 007 Jarhead Tank Alarm

007 Tank Alarms with DEF JARHEAD Tank Gauges.

- Tank gauge constructed from materials 100% compatible with Diesel Exhaust Fluid (DEF)
- Wall mount tank alarm can be installed up to 350 feet from tank
- Built-in 103 decibel siren
- Built-in, highly visible strobe light
- Tank alarm includes a push button test switch
- Toggle switch to silence the siren and a flashing LED light warns when siren is muted
- AC power indicator light
- DEF Jarhead sightglass tank gauge indicates fluid level in fractions: empty - 1/4 - 1/2 - 3/4 - full
- Available in custom lengths from 12" - 120" (457.2 - 3048 mm)
- Durable silk screen painted scales
- Visi-Glo® level indicator clearly displayed in the large glass window
- Easy to use, adjustable sensor for high or low alarm

New Monitors and Alarms

MODEL NO.	DESCRIPTION	SHIPPING WEIGHT LBS (KG)
008666	Audible and visual tank alarm with 12-volt transformer and sightglass tank gauge with fractional indicators for 12" - 120" tank depth with 2" NPS connection	10 (4.5)

Construction

Body	Tank Alarm - Weather resistant ABS Tank Gauge - Large glass housing
Rods	Stainless steel
Fasteners	Stainless steel
Connectors	Acetal
Linkage	Acetal
Float	DEF Compatible Anodized Aluminum
Seals	Fluorocarbon
Connections	Tank Alarm - 1/2" Romex Connector Tank Gauge - 2" / 50.8 mm NPS threads



WARNING: Cancer and Reproductive Harm - www.P65Warnings.ca.gov

DEF 007 Jarhead Tank Alarm

007 Tank Alarms with DEF JARHEAD Tank Gauges.

Dimensions



DEF 007 Overfill Tank Alarm

007 Tank Alarms with DEF OVERFILL Guards.

- Tank gauge constructed from materials 100% compatible with Diesel Exhaust Fluid (DEF).
- Wall mount tank alarm can be installed up to 350 feet from tank.
- Built-in 103 decibel siren
- Built-in, highly visible strobe light
- Tank alarm includes a push button test switch.
- Toggle switch to silence the siren and a flashing LED light warns when siren is muted
- AC power indicator light
- DEF overfill guard tank gauge has durable silk screen painted graphics.
- Field adjustable length up to 72" (1,828.8 mm)
- Visi-Glo® level indicator clearly displayed in the large glass window
- Easy to use, adjustable sensor for high or low alarm

New Monitors and Alarms

MODEL NO.	DESCRIPTION	SHIPPING WEIGHT LBS (KG)
008667	Audible and visual tank alarm with 12-volt transformer and overfill guard tank gauge with 2" NPS connection	7.0 (3.2)

Construction

Body	Tank Alarm - Weather resistant ABS Tank Gauge - Large glass housing
Chain	Stainless steel
Fasteners	Stainless steel
Connectors	Acetal
Linkage	Acetal
Float	DEF Compatible Anodized Aluminum
Seals	Fluorocarbon
Connections	Tank Alarm - 1/2" Romex Connector Tank Gauge - 2" NPS threads



WARNING: Cancer and Reproductive Harm - www.P65Warnings.ca.gov

DEF 007 Overfill Tank Alarm

007 Tank Alarms with DEF OVERFILL Guards.

Dimensions



DEF Sentry Jarhead Alarm

Sentry Wall Mounted Tank Alarms with DEF JARHEAD Tank Gauges.

- Tank gauge constructed from materials 100% compatible with Diesel Exhaust Fluid (DEF).
- Wall mount tank alarm can be installed up to 350 feet from tank.
- Built-in 103 decibel siren
- Tank alarm includes a push button test switch.
- Toggle switch to silence the siren
- Available with battery or with optional 12-volt transformer
- DEF Jarhead sightglass tank gauge indicates fluid level in fractions: empty - 1/4 - 1/2 - 3/4 - full
- Available in custom lengths from 12" - 120" (457.2 - 3048 mm)
- Durable silk screen painted scales
- Visi-Glo® level indicator clearly displayed in the large glass window
- Easy to use, adjustable sensor for high or low alarm

New Monitors and Alarms

MODEL NO.	DESCRIPTION	SHIPPING WEIGHT LBS (KG)
008677	Audible tank alarm, battery operated, with sightglass tank gauge with fractional indicators for 12" - 120" tank depth with 2" NPS connection	5.5 (2.5)
008664	Audible tank alarm, with 12-volt transformer and sightglass tank gauge with fractional indicators for 12" - 120" tank depth with 2" NPS connection	6.5 (2.9)

Construction

Body	Tank Alarm - Weather resistant ABS Tank Gauge - Large glass housing
Rods	Stainless steel
Fasteners	Stainless steel
Connectors	Acetal
Linkage	Acetal
Float	DEF Compatible Anodized Aluminum
Seals	Fluorocarbon
Connections	Tank Alarm - 1/2" Romex Connector Tank Gauge - 2" / 50.8 mm NPS threads



 WARNING: Cancer and Reproductive Harm - www.P65Warnings.ca.gov

DEF Sentry Jarhead Alarm

Sentry Wall Mounted Tank Alarms with DEF JARHEAD Tank Gauges.

Dimensions and System Options

Accessories

MODEL NO.	DESCRIPTION
008673	DEF Remote Jarhead Sensor

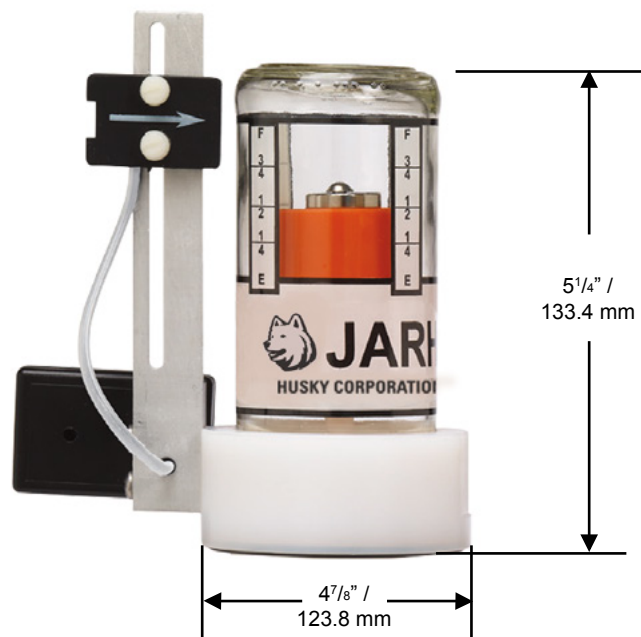

DEF Sentry Overfill Alarm

Sentry Wall Mounted Tank Alarms with DEF OVERFILL Guards.

- Tank gauge constructed from materials 100% compatible with Diesel Exhaust Fluid (DEF).
- Wall mount tank alarm can be installed up to 350 feet from tank.
- Built-in 103 decibel siren
- Tank alarm includes a push button test switch.
- Toggle switch to silence the siren
- Available with battery or with optional 12-volt transformer
- DEF overfill guard tank gauge has durable silk screen painted graphics.
- Available with field adjustable chain up to 72" (1,828.8 mm)
- Visi-Glo® level indicator clearly displayed in the large glass window
- Easy to use, adjustable sensor for high or low alarm

New Monitors and Alarms

MODEL NO.	DESCRIPTION	SHIPPING WEIGHT LBS (KG)
008668	Audible tank alarm, battery operated, with overfill guard tank gauge with 2" NPS connection	5.5 (2.5)
008669	Audible tank alarm, with 12-volt transformer and overfill guard tank gauge with 2" NPS connection	5.5 (2.5)

Construction

Body	Tank Alarm - Weather resistant ABS Tank Gauge - Large glass housing
Rods	Stainless steel
Fasteners	Stainless steel
Connectors	Acetal
Linkage	Acetal
Float	DEF Compatible Anodized Aluminum
Seals	Fluorocarbon
Connections	Tank Alarm - 1/2" Romex Connector Tank Gauge - 2" / 50.8 mm NPS threads



⚠️ WARNING: Cancer and Reproductive Harm - www.P65Warnings.ca.gov

DEF Sentry Overfill Alarm

Sentry Wall Mounted Tank Alarms with DEF OVERFILL Guards.

Dimensions and System Options

Accessories

MODEL NO.	DESCRIPTION
008674	DEF Remote Overfill Guard Sensor



55 Drum Alert

Low and High Drum Alert.

- Waterproof self-contained housing to ensure contaminate-free monitoring
- Vented design
- 9-volt battery powered, provided
- 103 decibel alarm siren
- Yellow LED low battery indicator light
- Audible low battery indicator chirp
- On/Off/Test switch
- PVC and ABS plastics construction
- Not recommended for liquids with a specific gravity less than .85
- Fits in 3/4" NPT vent opening
- UL Buna N sensor
- Hi level actuation point = 3"
Low level actuation point = 2"
- Simple installation
- Easy battery replacement
- Audible alert
- Housing can be rotated for best viewing orientation.
- Less expensive than comparable monitors
- 2 plus year battery life
- Alarm sounds for 12 plus hours



New 55 Gallon Drum Alert

MODEL NO.	DESCRIPTION	SHIPPING WEIGHT LBS (KG)
009952	Drum "55" Alert Low	1.0 (0.45)
009953	Drum "55" Alert High	.66 (0.3)
013883	SHM1 Outdoor Tank Monitor with Remote Sensor	1.35 (0.6)



WARNING: Cancer and Reproductive Harm - www.P65Warnings.ca.gov

55 Drum Alert

Low and High Drum Alert.

Dimensions



55 Drum Alarm

Low, 007 and SENTRY 55 gallon drum alarm.

- Compact low profile sensor housing
- Vented or sealed design
- Waterproof cord grip and housing to prevent external contamination of barrel contents
- 10 foot sensor leads for convenient installation to SENTRY or 007 control panels
- Not recommended for liquids with a specific gravity less than .85
- Fits in 3/4" NPT vent opening
- UL Buna N sensor
- Hi level actuation point = 3"
Low level actuation point = 32"
- Interfaces with existing SENTRY or 007 tank monitors
- Combined with a SENTRY or 007 tank monitors, multiple barrels can be monitored at the same time (additional remote barrel sensors required)
- Less expensive than comparable monitor

New 007 55 Gallon Drum Alarm

MODEL NO.	DESCRIPTION	SHIPPING WEIGHT LBS (KG)
009503	Remote 55 Gallon Drum High Level Alarm	.25 (0.1)
009980	Remote 55 Gallon Drum Low Level Sealed Alarm	.45 (0.2)
010000	Remote 55 Gallon Drum High Level Sealed Alarm	.25 (0.1)

New SENTRY 55 Gallon Drum Alarm

MODEL NO.	DESCRIPTION	SHIPPING WEIGHT LBS (KG)
010821	Remote 55 Gallon Drum Low Level Alarm	.45 (0.2)
010824	Remote 55 Gallon Drum High Level Sealed Alarm	.25 (0.1)



High Alarm



Low Alarm



WARNING: Cancer and Reproductive Harm - www.P65Warnings.ca.gov

55 Drum Alarm

Low, 007 and SENTRY 55 gallon drum alarm.

Dimensions

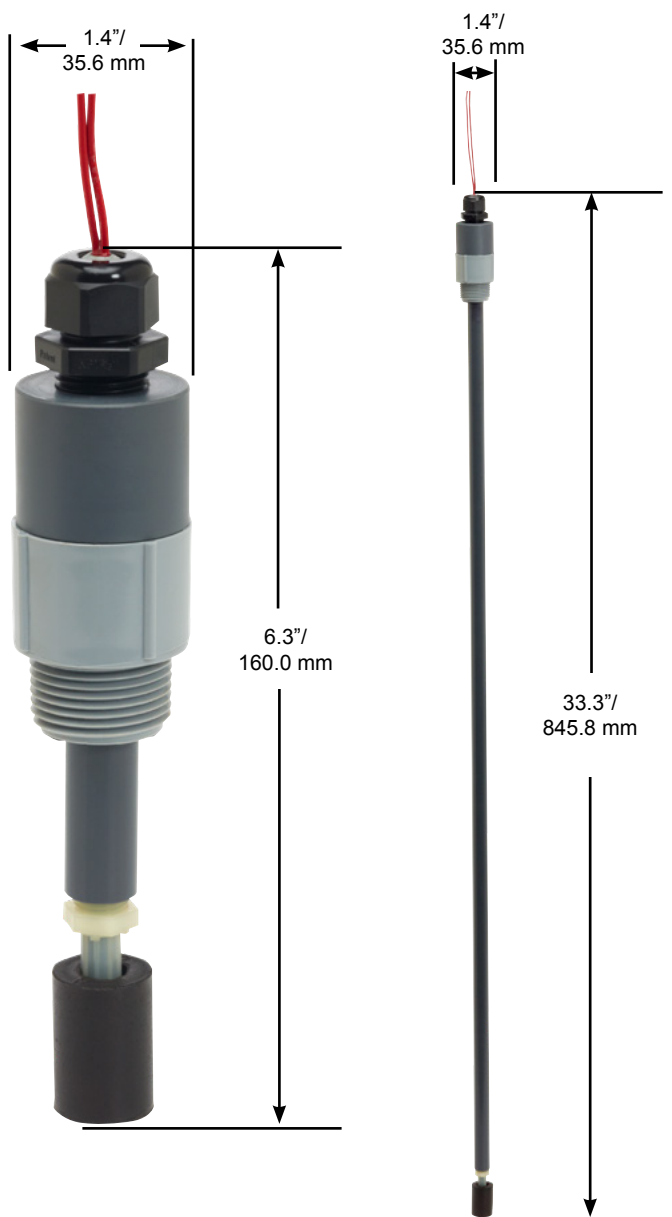

FNTM Drum Gauge

FNTM 55 Gallon Drum Gauge

- Waterproof self-contained housing to ensure contaminate-free monitoring
- AA battery powered, provided
- Touch gauge sides to activate LEDs
- Displays drum levels from 90% to 5%
- Alerts when the drum level is below 5%
- Low battery alert
- Audible low battery indicator chirp
- PVC and ABS Plastics Construction
- FNTM is designed to be used in standard metal 55 gallon drums.
- Fits in 3/4" NPT vent opening
- Simple installation
- Easy battery replacement
- Audible alert
- Less expensive than comparable monitors
- 2 plus year battery life

New 55 Gallon Drum Alert

MODEL NO.	DESCRIPTION	SHIPPING WEIGHT LBS (KG)
010807	FNTM 55 Gallon Drum Gauge	1.0 (0.45)



 WARNING: Cancer and Reproductive Harm - www.P65Warnings.ca.gov

FNTM Drum Gauge

FNTM 55 Gallon Drum Gauge

Dimensions

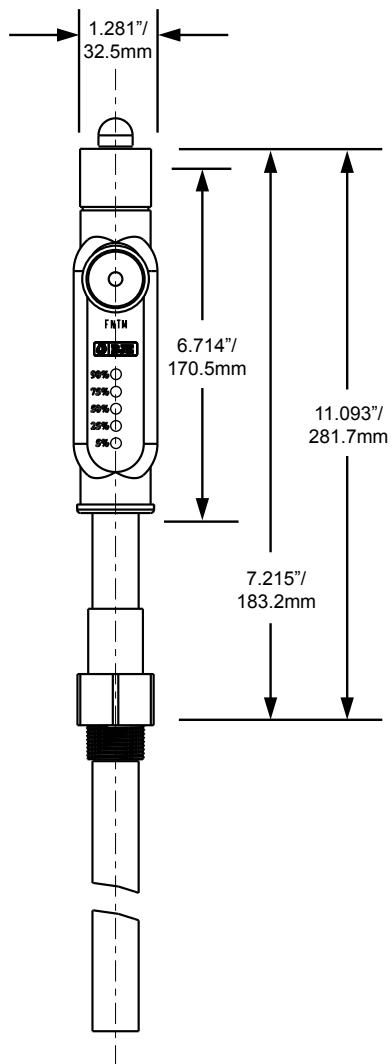

Kaltey Commander

Tank Controller

Tank Controller for use with oil, waste oil, diesel fuel, antifreeze, water and other fluids with a high flash point.

- Self-regulating fluid transfer system
- Provides automatic re-filling of monitored tank
- Prevents costly tank overfills
- Built in overfill monitoring-103 decibel alarm siren and flashing LED
- Push to fill button provides instant topping off of monitored tank
- Engineered for most single or double wall tanks with 2" NPT bung opening
- Designed for tank depths between 24"-78" (610 mm-1981 mm)
- Requires one air powered diaphragm pump not included
- System shuts off air to diaphragm pump and oil flow to day tank when high level sensor is tripped.
- System includes: Tank mounted controller, air solenoid valve, fluid control valve, 115 volt ac adaptor, 25 ft of cabling
- Tank depth and riser height information required at time of order
- New swivel allows easy orientation of gauge after installation

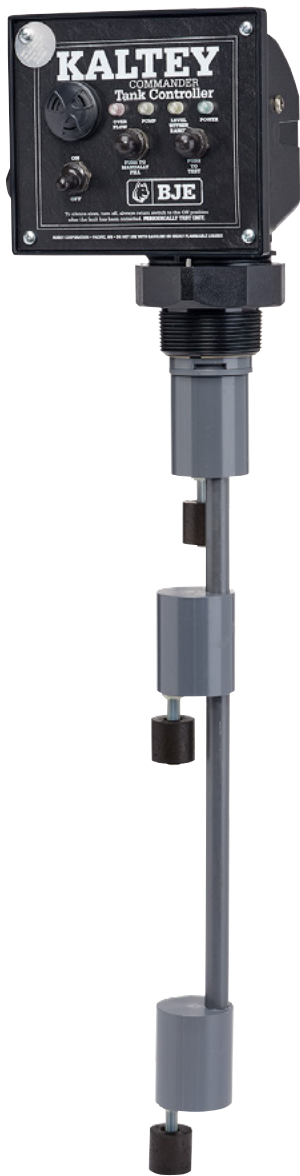

Monitors and Alarms

MODEL NO.	DESCRIPTION	SHIPPING WEIGHT LBS (KG)
010613	Kaltey Commander Tank Controller	14 (6.4)



 WARNING: Cancer and Reproductive Harm - www.P65Warnings.ca.gov

Kaltec Commander

Tank Controller

Tank Controller for use with oil, waste oil, diesel fuel, antifreeze, water and other fluids with a high flash point.

Dimensions

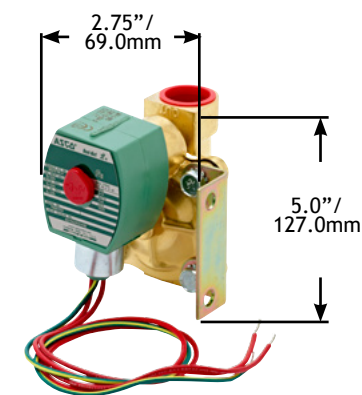
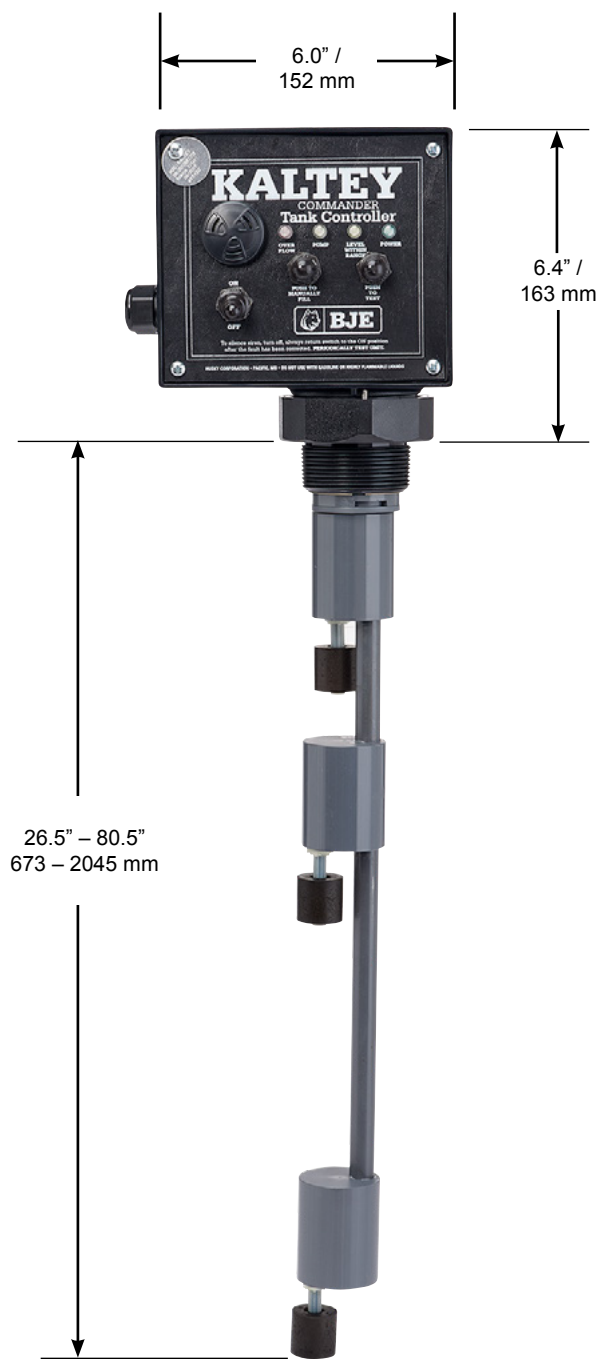

Kaltey Commander

Tank Controller—Wall Mount

Tank Controller for use with oil, waste oil, diesel fuel, antifreeze, water and other fluids with a high flash point.

- Self-regulating fluid transfer system
- Provides automatic re-filling of monitored tank
- Prevents costly tank overfills
- Built in overfill monitoring- 103 decibel alarm siren and flashing LED
- Push to fill button provides instant topping off of monitored tank
- Engineered for most single or double wall tanks with 2" NPT bung opening
- Designed for tank depths between 24"-78" (610 mm-1981 mm)
- Requires one air powered diaphragm pump not included
- System shuts off air to diaphragm pump and oil flow to day tank when high level sensor is tripped.
- System includes: wall mounted controller, air solenoid valve, fluid control valve, 115 volt ac adaptor, 25 ft of cabling
- Tank depth and riser height information required at time of order

Monitors and Alarms

MODEL NO.	DESCRIPTION	SHIPPING WEIGHT LBS (KG)
010614	Kaltey Commander Wall Mount Tank Controller	14 (6.4)

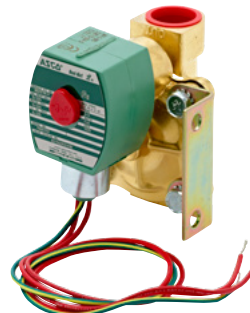

 WARNING: Cancer and Reproductive Harm - www.P65Warnings.ca.gov

Kaltey Commander Tank Controller—Wall Mount

Tank Controller for use with oil, waste oil, diesel fuel, antifreeze, water and other fluids with a high flash point.

Dimensions and System Options

Accessories

MODEL NO.	DESCRIPTION
013752	Kaltey Commander Wall Mount Tank Controller Remote Sensor

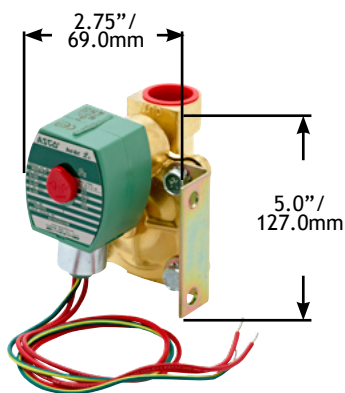
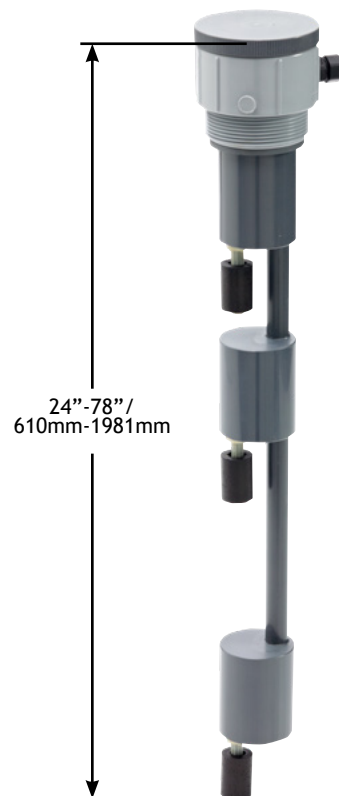

MK6 Tank Alarm

High/Low Tank Alarm for use with oil, waste oil, diesel fuel, antifreeze, water and other fluids with a high flash point.

- Monitor up to 6 tanks independently
- Tank probes sold separately
- Avoid costly overflows or untimely shortages
- Supervised system
- Low voltage
- Strobe and siren
- 6 independent LED displays to indicate which circuit is in alarm
- Easy installation
- Maximum milliamp load is 750 mA
- Capable of driving a solenoid valve for each tank monitored

New Gauges and Alarms

MODEL NO.	DESCRIPTION	SHIPPING WEIGHT LBS (KG)
014509	MK6 Audible and Visual Tank Gauge (includes indoor mount control panel, and 12 volt transformer)	4.0 (1.8)



! WARNING: Cancer and Reproductive Harm - www.P65Warnings.ca.gov

MK6 Tank Alarm

High/Low Tank Alarm for use with oil, waste oil, diesel fuel, antifreeze, water and other fluids with a high flash point.

Dimensions and System Options

Accessories

MODEL NO.	DESCRIPTION
007595	12 volt Transformer
007660	Remote Tank Sensor
007936*	Remote Jarhead Tank Sensor with 2" tank fitting
008206*	Remote Jarhead Tank Sensor with 1-1/2" tank fitting
007655	Remote Leak Guard Tank Sensor with 2" tank fitting
007656	Remote Leak Guard Tank Sensor with 1-1/2" tank fitting
007742	Remote Overfill Guard Tank Sensor with 2" tank fitting
007743	Remote Overfill Guard Tank Sensor with 1-1/2" tank fitting
007695	Strobe Light
007690	Siren - 107 Decibels
007645	Heavy Duty Power Relay - 30 amp or 1-1/2" HP at 120 or 240 vac
009502	Remote 55 Gallon Drum Low Level Sensor
009503	Remote 55 Gallon Drum High Level Sensor
009980	Remote 55 Gallon Drum Low Level Sealed Sensor
010000	Remote 55 Gallon Drum High Level Sealed Sensor

*Specify tank depth (in inches) and riser height (in inches).

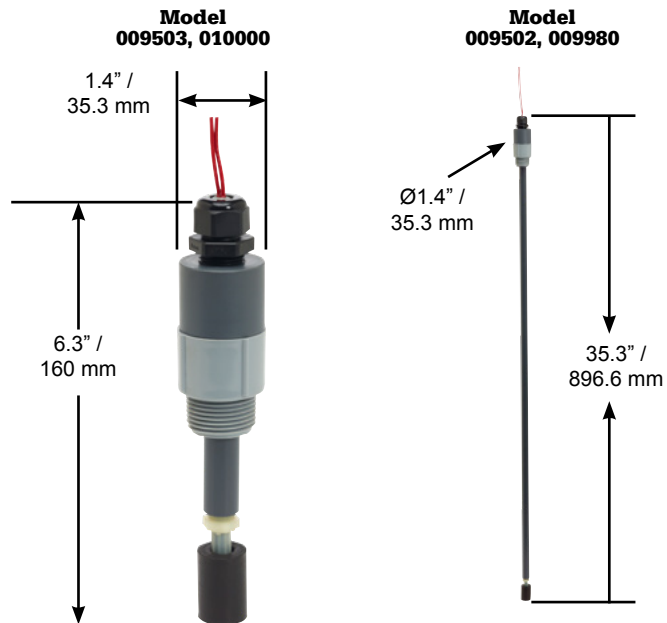

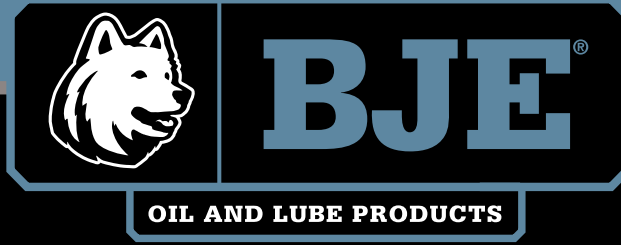

Gauge Accessories

AD 110 Drain Valve

Automatic Drain Valve.

- Automatically drains moisture from air compressor tanks, dryers, after coolers, etc.
- Delivers drier air extending life of tools and pneumatic equipment
- Eliminates manual draining - fully automatic - no maintenance
- 230 PSI maximum pressure
- ¼" NPT ports
- 6 ft. power cord
- 115 VAC power
- Adjustable cycle time from 1 - 45 minutes
- Adjustable discharge time from .25 - 25 seconds
- Manual test switch

New Valves

MODEL NO.	DESCRIPTION	SHIPPING WEIGHT LBS (KG)
007585	AD110 Electronic Drain Valve	1.0 (0.4)

Optional ¼" Y Strainer

Recommended for optimal performance, i.e. scaling, where air compressor rust can occur. Brass, includes screen.

007730	AD Y Strainer	1.0 (0.4)
--------	---------------	-----------



WARNING: Cancer and Reproductive Harm - www.P65Warnings.ca.gov

AD 110 Drain Valve

Automatic Drain Valve.

Dimensions



Solenoid Valve System

Keyed Remote Solenoid Valve System controls air supply to equipment with the turn of a key up to 2000 feet away. Helps assure air compressors or oil pumps are idled when unattended.

- Stop unauthorized use of pneumatic equipment
- Red LED indicates valve is on/open
- Prevent pilferage of bulk oil/ product inventory
- 12 volt DC, 1/2" NPT ports, 200 PSI max
- Low voltage
- Easy installation

New Valves

MODEL NO.	DESCRIPTION	SHIPPING WEIGHT LBS (KG)
007630	Keyed Remote Air Solenoid Valve System Control	4.0 (1.8)



 WARNING: Cancer and Reproductive Harm - www.P65Warnings.ca.gov

Solenoid Valve System

Keyed Remote Solenoid Valve System controls air supply to equipment with the turn of a key up to 2000 feet away. Helps assure air compressors or oil pumps are idled when unattended.

Dimensions

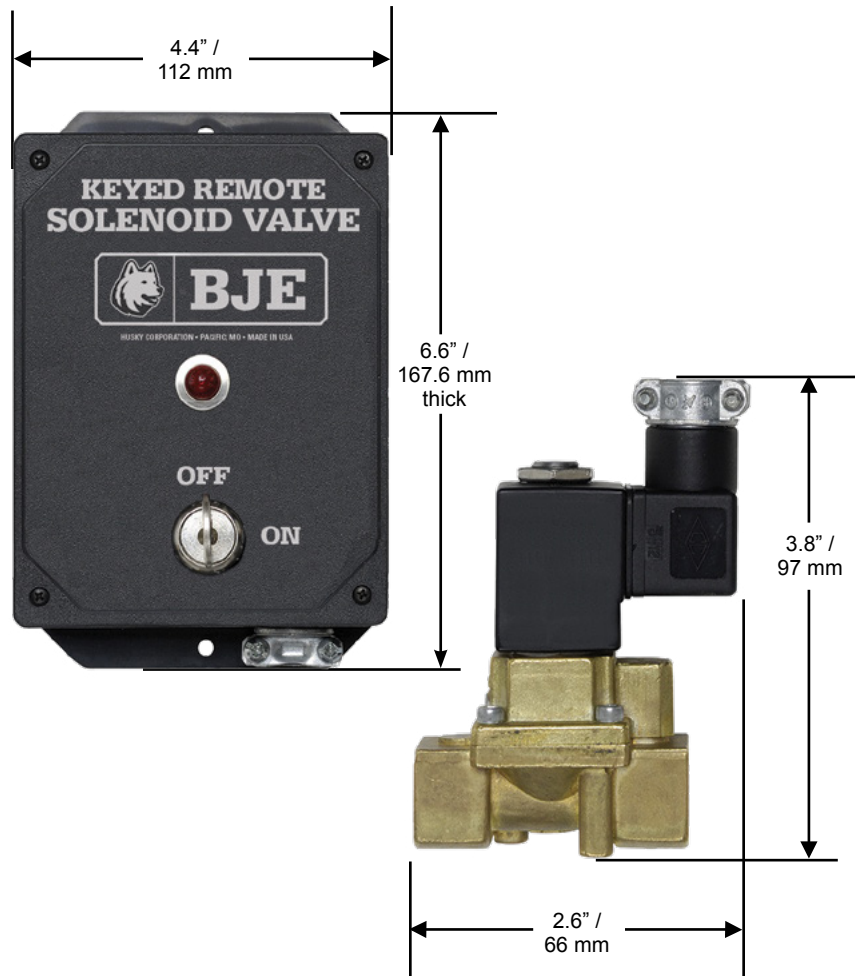

Solenoid Valves

For use with the 007 tank monitor.

007 SV Solenoid Valve

- Low voltage solenoid valve
- Shuts off air to pump when 007 is in alarm condition.
- Can be located up to 350' away from 007
- Wall mount transformer included
- 12V DC
- 1/2" NPT Ports
- 10-200 PSI

007 SVT Solenoid Valve with Timer

- Same as 007 SV with added timer

- SAVE TIME AND MONEY
- Shuts off pump, saving labor time and equipment failure due to unattended pump station
- Simply turn knob to desired time (3-15 min.) and get back to the job

Heavy Duty 007 Power Relay

- SPDT [N/O or N/C] dry contacts for a variety of applications, i.e. drive electric pumps, turn lights on/off, etc.
- 30 amp or 1-1/2 hp at 120 or 240 VAC

Specifying Information

MODEL NO.	DESCRIPTION	SHIPPING WEIGHT LBS (KG)
007645	Heavy Duty Power Relay for 007 Tank Gauge - 30 AMP or 1 1/2 HP at 120 or 240 VAC	1.0 (0.4)
007570	007 SVT Solenoid Valve with Timer - 12 Volt Electric (includes wall mount transformer)	5.0 (2.3)
007580	007 SV Solenoid Valve - 12 Volt Electric (includes wall mount transformer)	5.0 (2.3)

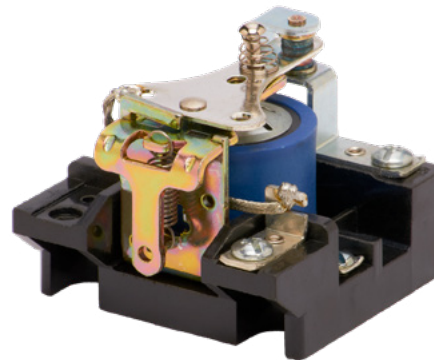

WARNING: Cancer and Reproductive Harm - www.P65Warnings.ca.gov

Solenoid Valves

For use with the 007 tank monitor.

Dimensions and System Options

Accessories

MODEL NO.	DESCRIPTION
007595	12 Volt Transformer

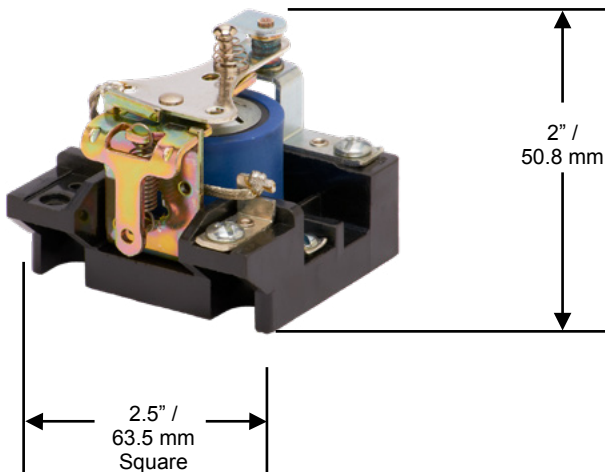

Siren/Sensor/Strobe

For all tank gauges.

107-Decibel Siren

- Ideal for remote locations
- Low voltage
- Can be located up to 350' away from 007 tank gauge with 18-gauge wire

Remote Tank Sensor

- Designed for use with Sentry or 007 tank gauge
- Ideal for 2nd sensor or interstitial space
- 1/2" x 6" PVC tube can be replaced for monitoring low tank. Please specify 007 or Sentry

- 2" and 1-1/2" NPT tank fittings available

Strobe Light

- Low voltage
- Ideal for remote locations
- Can be located up to 350' away from 007 tank gauge with 18-gauge wire

UL Transformer

- Self-resetting.

007 Gauges Accessories

MODEL NO.	DESCRIPTION	SHIPPING WEIGHT LBS (KG)
007695	Strobe Light for 007 Tank Gauge	0.4 (0.2)
007690	Siren for 007 Tank Gauge - 107 Decibels	0.1 (0.04)
007660	Remote Tank Sensor for 007 Tank Gauge	1.5 (0.7)
007936*	Remote Jarhead Tank Sensor for 007 Tank Gauge with 2" Tank Fitting	1.5 (0.7)
008206*	Remote Jarhead Tank Sensor for 007 Tank Gauge with 1 1/2" Tank Fitting	1.5 (0.7)
007655*	Remote Leak Guard Tank Sensor for 007 Tank Gauge with 2" Tank Fitting	2.0 (0.9)
007656*	Remote Leak Guard Tank Sensor for 007 Tank Gauge with 1 1/2" Tank Fitting	2.0 (0.9)
007742*	Remote Overfill Guard Tank Sensor for 007 Tank Gauge with 2" Tank Fitting	2.0 (0.9)
007743*	Remote Overfill Guard Tank Sensor for 007 Tank Gauge with 1 1/2" Tank Fitting	2.0 (0.9)
007595	12 Volt Transformer for 007 and Sentry Tank Gauges	1.5 (0.7)

Sentry Gauge Accessories

MODEL NO.	DESCRIPTION	SHIPPING WEIGHT LBS (KG)
007661	Remote Tank Sensor for Sentry Tank Gauge	1.5 (0.7)
007650*	Remote Jarhead Tank Sensor for Sentry Tank Gauge with 2" Tank Fitting	3.0 (1.4)
008211*	Remote Jarhead Tank Sensor for Sentry Tank Gauge with 1 1/2" Tank Fitting	3.0 (1.4)
007657*	Remote Leak Guard Tank Sensor for Sentry Tank Gauge with 2" Tank Fitting	2.0 (0.9)
007658*	Remote Leak Guard Tank Sensor for Sentry Tank Gauge with 1 1/2" Tank Fitting	2.0 (0.9)
007740*	Remote Overfill Guard Tank Sensor for Sentry Tank Gauge with 2" Tank Fitting	2.0 (0.9)
007741*	Remote Overfill Guard Tank Sensor for Sentry Tank Gauge with 1 1/2" Tank Fitting	2.0 (0.9)
007595	12 Volt Transformer for 007 and Sentry Tank Gauges	1.5 (0.7)

*Specify tank depth (in inches) and **riser height (in inches)



WARNING: Cancer and Reproductive Harm - www.P65Warnings.ca.gov

Siren/Sensor/Strobe

For all tank gauges.

Dimensions and System Options

007 Tank Gauges

MODEL NO.	DESCRIPTION
007575	007 Audible and Visual Tank Gauge (includes indoor mount control panel, remote tank sensor, 10' lead wire and 12 volt transformer)
007555*	007 Audible and Visual Tank Gauge with Jarhead Tank Gauge (includes indoor mount control panel, Jarhead Tank Gauge, and 12 volt transformer)
007560	007 Audible and Visual Tank Gauge with Leak Guard Tank Gauge (includes indoor mount control panel, Leak Guard Tank Gauge, remote strobe, remote siren, and 12 volt transformer)
007565	007 Audible and Visual Tank Gauge with Overfill Tank Gauge (includes indoor mount control panel, Overfill tank gauge, remote strobe, remote siren, and 12 volt transformer)

Sentry Tank Gauges

MODEL NO.	DESCRIPTION
007670	Sentry High or Low Battery Operated Tank Gauge with Built-in 103 Decibel Siren
007671	Sentry High or Low Tank Gauge with Built-in 103 Decibel Siren and 12 Volt Transformer
007675	Sentry High or Low Wall Mounted Battery Operated Tank Gauge with Built-in 103 Decibel Siren and Leak Guard Tank Gauge
007676	Sentry High or Low Wall Mounted Battery Operated Tank Gauge with Built-in 103 Decibel Siren, Leak Guard Tank Gauge and 12 Volt Transformer
007680	Sentry High or Low Wall Mounted Battery Operated Tank Gauge with Built-in 103 Decibel Siren and Overfill Tank Gauge
007681	Sentry High or Low Wall Mounted Battery Operated Tank Gauge with Built-in 103 Decibel Siren, Overfill Tank Gauge, and 12 Volt Transformer
007725	Sentry High or Low Wall Mounted Battery Operated Tank Gauge with Built-in 103 Decibel Siren
007726	Sentry High or Low Wall Mounted Battery Operated Tank Gauge with Built-in 103 Decibel Siren and 12 Volt Transformer
007685*	Sentry High or Low Wall Mounted Battery Operated Tank Gauge with Built-in 103 Decibel Siren and Jarhead Tank Gauge
007686*	Sentry High or Low Wall Mounted Battery Operated Tank Gauge with Built-in 103 Decibel Siren, Jarhead Tank Gauge, and 12 Volt Transformer

*Specify tank depth (in inches) and **riser height (in inches)



Accessories

MODEL NO.	DESCRIPTION
007829	Adaptor, 1-1/2" Jarhead
007865	Jar, Leak

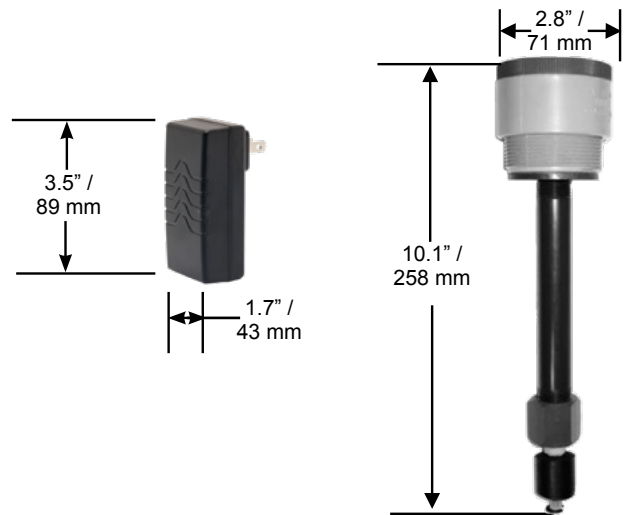

TM3 Valve

TM3 Air Shut-off Valve for use with oil, waste oil, diesel fuel, antifreeze, water and other fluids with a high flash point.

- Fully pneumatic - no electronic parts
- Avoid costly overflows or untimely inventory shortages
- Ideal for tanks with baffles
- Engineered for most single or double walled above ground storage tanks
- Aluminum float is not affected by oils or most other chemicals
- Shuts off air supply to pumps preventing tank overflows
- Easy installation
- Operating range 30-200 PSI

New Valves

MODEL NO.	DESCRIPTION	SHIPPING WEIGHT LBS (KG)
007700	TM3 Pneumatic Shut Off Valve	4.7 (2.1)



WARNING: Cancer and Reproductive Harm - www.P65Warnings.ca.gov

TM3 Valve

TM3 Air Shut-off Valve for use with oil, waste oil, diesel fuel, antifreeze, water and other fluids with a high flash point.

Dimensions and System Options

Replacement Parts

MODEL NO.	DESCRIPTION
007553	TM3 Replacement Chain
011425	TM3 Replacement Float
007774	TM3 Weight

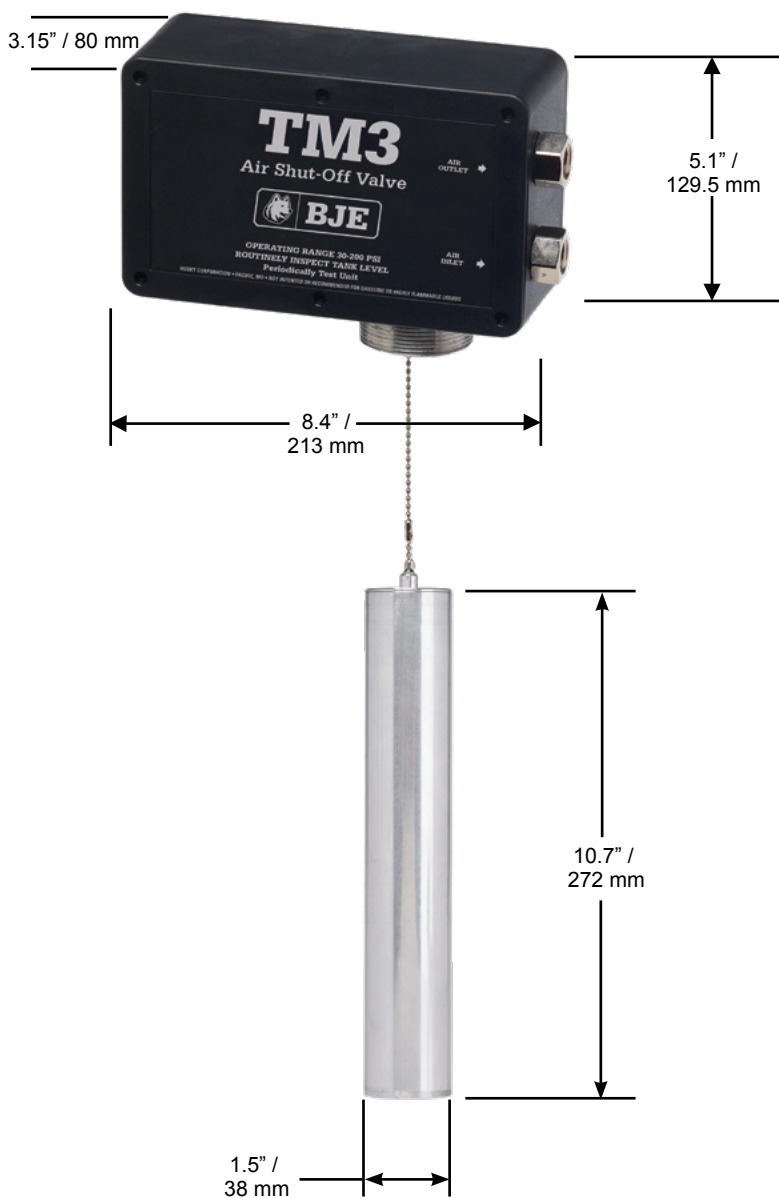



Hewitt Catalog



Aviation Hoses

4113 Permanent

4113 Permanent Fitting aviation fueling hose recommended for all types of riser deck, reel, and hydrant hose applications.

- Used for commercial and private aircraft
- Resistant to jet fuel and higher aromatic aviation gasolines
- Compatible with use on hydrant service
- Meets EI 1529, 7th Edition, 2014 and European Standard EN ISO 1825 (2011), Type C, Grade 2, NPFA 407
- Operating temperature -22 °F to +149 °F (-30 °C to +65 °C)
- Recommended for all types of riser deck, reel, and hydrant hose applications
- All aviation hose assemblies are 100% hydrostatic tested to 600 PSI and inspected for electrical continuity.
- Every hose receives a unique serial number and test certificate.



Specifying Information

MODEL NO.	DESCRIPTION	SHIPPING WEIGHT LBS (KG)
1" HOSES		
CP160024HABA	1" x 2' HEW 4113 MXM NPT BR NR	1.24 (0.6)
CP160180HABA	1" x 15' HEW 4113 MXM NPT BR NR	10.0 (4.5)
CP160360HABA	1" x 30' HEW 4113 MXM NPT BR NR	20.0 (9.1)
CP160420HABA	1" x 35' HEW 4113 MXM NPT BR NR	23.0 (10.5)
CP160472HABA	1" x 39' 4" HEW 4113 MXM NPT BR NR	25.0 (11.3)
CP160480HABA	1" x 40' HEW 4113 MXM NPT BR NR	26.0 (11.8)
CP160588HABA	1" x 49' HEW 4113 MXM NPT BR NR	30.4 (13.8)
CP160600HABA	1" x 50' HEW 4113 MXM NPT BR NR	32.0 (14.5)
CP160720HABA	1" x 60' HEW 4113 MXM NPT BR NR	38.0 (17.3)
CP160792HABA	1" x 66' HEW 4113 MXM NPT BR NR	42.0 (19.1)
CP160900HABA	1" x 75' HEW 4113 MXM NPT BR NR	48.0 (21.8)
CP160960HABA	1" x 80' HEW 4113 MXM NPT BR NR	51.0 (23.1)
CP161080HABA	1" x 90' HEW 4113 MXM NPT BR NR	57.0 (25.9)
CP161200HABA	1" x 100' HEW 4113 MXM NPT BR NR	63.0 (28.6)
CP161380HABA	1" x 115' HEW 4113 MXM NPT BR NR	71.3 (32.4)
CP161560HABA	1" x 130' HEW 4113 MXM NPT BR NR	80.6 (36.6)
1 1/4" HOSES		
CP200600HABA	1 1/4" x 50' HEW 4113 MXM NPT BR NR	42.0 (19.1)
CP200660HABA	1 1/4" x 55' HEW 4113 MXM NPT BR NR	45.0 (20.1)
CP200792HABA	1 1/4" x 66' HEW 4113 MXM NPT BR NR	54.0 (24.5)
CP200840HBBA	1 1/4" x 70' HEW 4113 MXF NPT BR NR	57.0 (25.9)
CP200900HABA	1 1/4" x 75' HEW 4113 MXM NPT BR NR	61.0 (27.8)
CP201176HABA	1 1/4" x 98' HEW 4113 MXM NPT BR NR	77.4 (35.2)
CP201200HBBA	1 1/4" x 100' HEW 4113 MXF NPT BR NR	81.0 (36.8)
CP201200HABA	1 1/4" x 100' HEW 4113 MXM NPT BR NR	81.0 (36.8)
1 1/2" HOSES		
CP240024HABA	1 1/2" x 2' HEW 4113 MXM NPT BR NR	1.7 (0.8)
CP240108HABA	1 1/2" x 9' HEW 4113 MXM NPT BR NR	11.0 (5.0)
CP240120HABA	1 1/2" x 10' HEW 4113 MXM NPT BR NR	12.0 (5.5)
CP240600HABA	1 1/2" x 50' HEW 4113 MXM NPT BR NR	51.0 (23.2)
CP240720HABA	1 1/2" x 60' HEW 4113 MXM NPT BR NR	61.0 (27.8)
CP240780HBBA	1 1/2" x 65' HEW 4113 MXF NPT BR NR	66.0 (30.0)
CP240792HABA	1 1/2" x 66' HEW 4113 MXM NPT BR NR	67.0 (30.5)
CP240840HABA	1 1/2" x 70' HEW 4113 MXM NPT BR NR	71.0 (32.3)
CP240900HABA	1 1/2" x 75' HEW 4113 MXM NPT BR NR	76.0 (34.5)
CP241020HABA	1 1/2" x 85' HEW 4113 MXM NPT BR NR	85.0 (38.6)
CP241200HABA	1 1/2" x 100' HEW 4113 MXM NPT BR NR	100.0 (45.5)
CP241200HBBA	1 1/2" x 100' HEW 4113 MXF NPT BR NR	100.0 (45.5)

MODEL NO.	DESCRIPTION	SHIPPING WEIGHT LBS (KG)
CP240420HABA	1 1/2" x 35' HEW 4113 MXM NPT BR NR	36.0 (16.4)
CP240684HABA	1 1/2" x 57' HEW 4113 MXM NPT BR NR	49.0 (22.3)
CP240780HABA	1 1/2" x 65' HEW 4113 MXM NPT BR NR	66.0 (30.0)
CP241368HABA	1 1/2" x 114' HEW 4113 MXM NPT BR NR	98.0 (44.5)
CP241800HABA	1 1/2" x 150' HEW 4113 MXM NPT BR NR	129.0 (58.6)
2" HOSES		
CP320120HABA	2" x 10' HEW 4113 MXM NPT BR NR	16.0 (7.3)
CP320134HABA	2" x 11.17' HEW 4113 MXM NPT BR NR	13.4 (6.1)
CP320144HABA	2" x 12' HEW 4113 MXM NPT BR NR	19.0 (8.6)
CP320180HABA	2" x 15' HEW 4113 MXM NPT BR NR	23.0 (10.5)
CP320197HABA	2" x 16' 5" HEW 4113 MXM NPT BR NR	24.0 (10.9)
CP320216HABA	2" x 18' HEW 4113 MXM NPT BR NR	26.0 (11.8)
CP320240HABA	2" x 20' HEW 4113 MXM NPT BR NR	29.0 (13.2)
CP320420HABA	2" x 35' HEW 4113 MXM NPT BR NR	49.0 (22.3)
CP320480HABA	2" x 40' HEW 4113 MXM NPT BR NR	55.0 (25.0)
CP320564HABA	2" x 47' HEW 4113 MXM NPT BR NR	56.4 (25.6)
CP320600HABA	2" x 50' HEW 4113 MXM NPT BR NR	68.0 (30.9)
CP320600HBBA	2" x 50' HEW 4113 MXF NPT BR NR	68.0 (30.9)
CP320684HABA	2" x 57' HEW 4113 MXM NPT BR NR	68.4 (31.1)
CP320720HABA	2" x 60' HEW 4113 MXM NPT BR NR	81.0 (36.8)
CP320792HABA	2" x 66' HEW 4113 MXM NPT BR NR	89.0 (40.5)
CP320900HABA	2" x 75' HEW 4113 MXM NPT BR NR	101.0 (45.9)
2 1/2" HOSES		
CP400096HABA	2 1/2" x 8' HEW 4113 MXM NPT BR NR	19.0 (8.6)
CP400108HABA	2 1/2" x 9' HEW 4113 MXM NPT BR NR	20.0 (9.1)
CP400120HBBA	2 1/2" x 10' HEW 4113 MXF NPT BR NR	22.0 (10.0)
CP400120HABA	2 1/2" x 10' HEW 4113 MXM NPT BR NR	22.0 (10.0)
CP400144HABA	2 1/2" x 12' HEW 4113 MXM NPT BR NR	25.0 (11.4)
CP400156HABA	2 1/2" x 13' HEW 4113 MXM NPT BR NR	27.0 (12.3)
CP400192HABA	2 1/2" x 16' HEW 4113 MXM NPT BR NR	32.0 (14.5)
CP400197HABA	2 1/2" x 16' 5" HEW 4113 MXM NPT BR NR	33.0 (15.0)
CP400420HABA	2 1/2" x 35' HEW 4113 MXM NPT BR NR	64.0 (29.1)
CP400480HABA	2 1/2" x 40' HEW 4113 MXM NPT BR NR	73.0 (33.2)
CP400600HBBA	2 1/2" x 50' HEW 4113 MXF NPT BR NR	90.0 (40.9)
CP400600HABA	2 1/2" x 50' HEW 4113 MXM NPT BR NR	90.0 (40.9)
CP400660HABA	2 1/2" x 55' HEW 4113 MXM NPT BR NR	98.0 (44.5)
CP400720HABA	2 1/2" x 60' HEW 4113 MXM NPT BR NR	106.0 (48.2)
CP40084HABA	2 1/2" x 7' HEW 4113 MXM NPT BR NR	17.0 (7.7)
CP400118HABA	2 1/2" x 9' 3" HEW 4113 MXM NPT BR NR	20.0 (9.1)



! WARNING: Cancer and Reproductive Harm - www.P65Warnings.ca.gov

4113 Permanent

4113 Permanent Fitting aviation fueling hose recommended for all types of riser deck, reel, and hydrant hose applications.

MODEL NO.	DESCRIPTION	SHIPPING WEIGHT LBS (KG)
CP400132HABA	2 ¹ / ₂ " x 11' HEW 4113 MXM NPT BR NR	34.0 (15.5)
CP400180HABA	2 ¹ / ₂ " x 15' HEW 4113 MXM NPT BR NR	30.0 (13.6)
CP400240HABA	2 ¹ / ₂ " x 20' HEW 4113 MXM NPT BR NR	39.0 (17.7)
CP400684HABA	2 ¹ / ₂ " x 57' HEW 4113 MXM NPT BR NR	100.0 (45.5)
CP401200HBBA	2 ¹ / ₂ " x 100' HEW 4113 MXF NPT BR NR	174.0 (79.1)
3" HOSES		
CP480096HABA	3" x 8' HEW 4113 MXM NPT BR NR	28.0 (12.7)
CP480108HABA	3" x 9' HEW 4113 MXM NPT BR NR	31.0 (14.1)
CP480120HABA	3" x 10' HEW 4113 MXM NPT BR NR	34.0 (15.5)
CP480132HABA	3" x 11' HEW 4113 MXM NPT BR NR	36.0 (16.4)
CP480144HABA	3" x 12' HEW 4113 MXM NPT BR NR	39.0 (17.7)
CP480168HABA	3" x 14' HEW 4113 MXM NPT BR NR	44.0 (20.0)
CP480180HABA	3" x 15' HEW 4113 MXM NPT BR NR	46.0 (20.9)
CP480240HABA	3" x 20' HEW 4113 MXM NPT BR NR	59.0 (26.8)
CP480360HBBA	3" x 30' HEW 4113 MXF NPT BR NR	85.0 (38.6)
CP480600HBBA	3" x 50 FT HEW 4113 MXF NPT BR NR	136.0 (61.8)
CP480600HABA	3" x 50' HEW 4113 MXM NPT BR NR	136.0 (61.8)
CP480720HABA	3" x 60' HEW 4113 MXM NPT BR NR	162.0 (73.6)

Construction

Tube	Black nitrile synthetic rubber
Cover	Black neoprene static dissipating/static conductive synthetic rubber (wrapped finish)
Reinforcement	Spiral-plyed (4) synthetic fabric and one nylon breaker
Couplings	Permanent brass internally expanded fittings - male and female NPT (swivel nut) Reusable 4-bolt aluminum clamp fittings - male and female, NPT and BSP threads - all females have swivel nuts - available with brass, tin plated brass, and stainless inserts

Order Guide (Ex. CP320600HABA)

AVIATION HOSE SIZE - CPSS

3/4" = CP12	2" = CP32
1" = CP16	2 1/2" = CP40
1 1/4" = CP20	3" = CP48
1 1/2" = CP24	4" = CP64

HOSE LENGTH (IN INCHES) - LLLL

0600 = 50 feet 0 inches
0606 = 50 feet 6 inches

AVIATION HOSE - H or J

H = 4113 Aviation Hose
J = 5500 JacRiser Hose

FITTING STYLE - S

A = Male x Male NPT Not Reusable
B = Male x Female NPT not Reusable
C = Female x Female NPT Not Reusable
D = Male x Male NPT Reusable
E = Male x Female NPT Reusable
F = Female x Female NPT Reusable
J = Male x Male BSP Reusable
K = Male x Female BSP Reusable
L = Female x Female BSP Reusable
S = Special (See Note 1)

FITTING BRAND - F

A = Internal Expansion Permanent (stainless steel only)
B = Dixon/UMI Internal Expansion (Permanent Brass Insert)
D = Dixon Swaged
E = Dixon Reusable
F = Elaflex Reusable
G = Roman Seliger Reusable

INSERT MATERIAL - M

A = Brass
B = Stainless Steel
D = Tin-Plated Brass
F = Carbon Steel

OVERALL LENGTH - O

For all sizes except CP64, if "0" is present, LLLL = OAL
For CP64 only, if blank, LLLL = OAL
For CP64 only, if "C" present, LLLL = Cut Length

Available in these Sizes

ID	NOM OD		MAX WP		WEIGHT		
	Size	MM	IN	MM	PSI	MPA	LB/FT
3/4"	19	1.25	31.8	300	2.07	0.50	0.75
1"	25	1.50	38.0	300	2.07	0.62	0.93
1 1/4"	32	1.78	45.2	300	2.07	0.79	1.18
1 1/2"	38	2.06	52.3	300	2.07	0.86	1.28
2"	50	2.57	65.3	300	2.07	1.20	1.79
2 1/2"	63	3.20	81.2	300	2.07	1.69	2.52
3"	75	3.70	94.0	300	2.07	2.33	3.47
4"	102	4.94	125.0	300	2.07	3.30	4.92

Couplings

Permanent Brass	Internally expanded fittings (standard for 3/4" and 3" ID) - male NPT and female NPS (swivel nut)
Crimped on Stainless	Male NPT (zinc-plated ferrules) standard for 4" ID hose assemblies. Internally expanded brass male NPT and NPS are also available.
Reusable 4-Bolt	Aluminum clamp fittings - male and female, NPT and BSP threads - all females have swivel nuts - available with brass, tin-plated brass and stainless inserts.

Protective Coils

9746	2" Banding Coil, White
9744	3" Banding Coil, White
9774	4" Banding Coil, White

NOTE:

If special, the next two digits will be used sequentially first using numbers (0-9) then using Alpha (A-Z). Special fittings or special materials will be described in the fab/shipping instructions section of the factory order. See separate assembly drawing for each special assembly number.

4113 Reusable

4113 with Reusable couplings aviation fueling hose recommended for all types of riser deck, reel, and hydrant hose applications.

- Used for commercial and private aircraft
- Resistant to jet fuel and higher aromatic aviation gasolines
- Compatible with use on hydrant service
- Meets EI 1529, 7th Edition, 2014 and European Standard EN ISO 1825 (2011), Type C, Grade 2, NPFA 407
- Recommended for all types of riser deck, reel, and hydrant hose applications
- All aviation hose assemblies are 100% hydrostatic tested to 600 PSI and inspected for electrical continuity.
- Every hose receives a unique serial number and test certificate.
- Standard hose assemblies are supplied with Roman Seliger brand 4-bolt aluminum clamp reusable couplings. Elaflex Spannloc are available on request.
- All 4" ID hoses utilize Roman Seliger 4-bolt aluminum clamped reusable fittings.

Specifying Information

MODEL NO.	DESCRIPTION	SHIPPING WEIGHT LBS (KG)
1 1/2" HOSES		
CP240720HKGB	1 1/2" X 60' 4113 MXF BSP SS RU	51.6 (23.5)
CP240792HEGA	1 1/2" X 66' 4113 MXF NPT BR RU	56.8 (25.8)
2" HOSES		
CP320720HKGB	2" x 60' 4113 MXF BSP SS RU	72.0 (32.7)
CP320720HKGA	2" x 60' 4113 MXF BSP BR RU	72.0 (32.7)
CP320792HEGA	2" x 66' 4113 MXF NPT BR RU	79.2 (36.0)
2 1/2" HOSES		
CP400120HEGD	2 1/2" x 10' 4113 MXF BSP TP RU	16.9 (7.7)
CP400144HEGD	2 1/2" x 12' 4113 MXF BSP TP RU	20.3 (9.2)
CP400156HDGB	2 1/2" x 13' 4113 MXM NPT SS RU	22.0 (10.0)
3" HOSES		
CP480144HEGD	3" x 12' 4113 MXF BSP TP RU	28.0 (12.7)
CP480168HABA	3" x 14' 4113 MXM NPT BR RU	32.6 (14.8)
CP480240HEGD	3" x 20' 4113 MXF BSP TP RU	46.6 (21.2)
CP480300HEGD	3" x 25' 4113 MXF BSP TP RU	58.3 (26.5)
CP480396HDGB	3" x 33' 4113 MXM NPT SS RU	76.9 (36.3)
CP480480HEGD	3" x 40' 4113 MXF BSP TP RU	93.2 (42.4)
4" HOSES		
CP640144HEGD	4" x 12' 4113 MXF BSP TP RU	39.6 (18.0)
CP640394HEGD	4" x 32.8' 4113 MXF BSP TP RU	108.2 (49.2)
CP640432HKGD	4" x 46' 4113 MXF BSP TP RU	151.8 (69.0)

Construction

Tube	Black nitrile synthetic rubber
Cover	Black neoprene static dissipating/static conductive synthetic rubber (wrapped finish)
Reinforcement	Spiral-plied (4) synthetic fabric and one nylon breaker



WARNING: Cancer and Reproductive Harm - www.P65Warnings.ca.gov

4113 Reusable

4113 with Reusable couplings aviation fueling hose recommended for all types of riser deck, reel, and hydrant hose applications.

Available in these Sizes

Size	NOM OD		MAX WP		WEIGHT		
	MM	IN	MM	PSI	MPA	LB/FT	KG/M
3/4"	19	1.25	31.8	300	2.07	0.50	0.75
1"	25	1.50	38.0	300	2.07	0.62	0.93
1 1/4"	32	1.78	45.2	300	2.07	0.79	1.18
1 1/2"	38	2.06	52.3	300	2.07	0.86	1.28
2"	50	2.57	65.3	300	2.07	1.20	1.79
2 1/2"	63	3.20	81.2	300	2.07	1.69	2.52
3"	75	3.70	94.0	300	2.07	2.33	3.47
4"	102	4.94	125.0	300	2.07	3.30	4.92

Couplings

Permanent	Brass male and female NPT (swivel nut)
Reusable 4-bolt	Aluminum clamp fittings - male and female, NPT and BSP threads - all females have swivel nuts - available with brass, tin plated brass, and stainless inserts Aluminum male available for 2, 2 1/2 and 3-inch ID

Protective Coils

9746	2" Banding Coil, White
9744	3" Banding Coil, White
9774	4" Banding Coil, White
9793	3" Banding Coil, Orange

Order Guide (Ex. CP320600HABA)

AVIATION HOSE SIZE - CPSS

3/4" = CP12	2" = CP32
1" = CP16	2 1/2" = CP40
1 1/4" = CP20	3" = CP48
1 1/2" = CP24	4" = CP64

HOSE LENGTH (IN INCHES) - LLLL

0600 = 50 feet 0 inches
0606 = 50 feet 6 inches

AVIATION HOSE - H or J

H = 4113 Aviation Hose
J = 5500 JacRiser Hose

FITTING STYLE - S

A = Male x Male NPT Not Reusable
B = Male x Female NPT not Reusable
C = Female x Female NPT Not Reusable
D = Male x Male NPT Reusable
E = Male x Female NPT Reusable
F = Female x Female NPT Reusable
J = Male x Male BSP Reusable
K = Male x Female BSP Reusable
L = Female x Female BSP Reusable
S = Special (See Note 1)

FITTING BRAND - F

A = Internal Expansion Permanent (stainless steel only)
B = Dixon/UMI Internal Expansion (Permanent Brass Insert)
D = Dixon Swaged
E = Dixon Reusable
F = Elaflex Reusable
G = Roman Seliger Reusable

INSERT MATERIAL - M

A = Brass
B = Stainless Steel
D = Tin-Plated Brass
F = Carbon Steel

OVERALL LENGTH - O

For all sizes except CP64, if "O" is present, LLLL = OAL
For CP64 only, if blank, LLLL = OAL
For CP64 only, if "C" present, LLLL = Cut Length

NOTE:

If special, the next two digits will be used sequentially first using numbers (0-9) then using Alpha (A-Z). Special fittings or special materials will be described in the fab/shipping instructions section of the factory order. See separate assembly drawing for each special assembly number.

4113CT Permanent

4113CT Cold Temperature Hose Permanent Fitting aviation fueling hose recommended for all types of riser deck, reel, and hydrant hose applications.

- Used for commercial and private aircraft
- Resistant to jet fuel and higher aromatic aviation gasolines
- Compatible with use on hydrant service
- Meets EI 1529, 7th Edition, 2014 and European Standard EN ISO 1825 (2011), Type CT, Grade 2, NPFA 407 and MIL-DTL-6615G
- Operating temperature -67 °F to +158 °F (-55 °C to +70 °C)
- Recommended for all types of riser deck, reel, and hydrant hose applications
- All aviation hose assemblies are 100% hydrostatic tested to 600 PSI and inspected for electrical continuity.
- Every hose receives a unique serial number and test certificate.



Specifying Information

MODEL NO.	DESCRIPTION	SHIPPING WEIGHT LBS (KG)
1" HOSES		
CP160024CABA	1" x 2' HEW 4113CT MM NPT BR NR	1.24 (0.6)
CP160180CABA	1" x 15' HEW 4113CT MM NPT BR NR	10.0 (4.5)
CP160360CABA	1" x 30' HEW 4113CT MM NPT BR NR	20.0 (9.1)
CP160420CABA	1" x 35' HEW 4113CT MM NPT BR NR	23.0 (10.5)
CP160472CABA	1" x 39' 4" HEW 4113CT MM NPT BR NR	25.0 (11.3)
CP160480CABA	1" x 40' HEW 4113CT MM NPT BR NR	26.0 (11.8)
CP160588CABA	1" x 49' HEW 4113CT MM NPT BR NR	30.4 (13.8)
CP160600CABA	1" x 50' HEW 4113CT MM NPT BR NR	32.0 (14.5)
CP160720CABA	1" x 60' HEW 4113CT MM NPT BR NR	38.0 (17.3)
CP160792CABA	1" x 66' HEW 4113CT MM NPT BR NR	42.0 (19.1)
CP160900CABA	1" x 75' HEW 4113CT MM NPT BR NR	48.0 (21.8)
CP160960CABA	1" x 80' HEW 4113CT MM NPT BR NR	51.0 (23.1)
CP161080CABA	1" x 90' HEW 4113CT MM NPT BR NR	57.0 (25.9)
CP161200CABA	1" x 105' HEW 4113CT MM NPT BR NR	63.0 (28.6)
CP161380CABA	1" x 115' HEW 4113CT MM NPT BR NR	71.3 (32.4)
CP161560CABA	1" x 130' HEW 4113CT MM NPT BR NR	80.6 (36.6)
1 1/4" HOSES		
CP200600CABA	1 1/4" x 50' HEW 4113CT MM NPT BR NR	42.0 (19.1)
CP200660CABA	1 1/4" x 55' HEW 4113CT MM NPT BR NR	45.0 (20.1)
CP200792CABA	1 1/4" x 66' HEW 4113CT MM NPT BR NR	54.0 (24.5)
CP200840CABA	1 1/4" x 70' HEW 4113CT MF NPT BR NR	57.0 (25.9)
CP200900CABA	1 1/4" x 75' HEW 4113CT MM NPT BR NR	61.0 (27.8)
CP201176CABA	1 1/4" x 98' HEW 4113CT MM NPT BR NR	77.4 (35.2)
CP201200CBBA	1 1/4" x 100' HEW 4113CT MF NPT BR NR	81.0 (36.8)
CP201200CABA	1 1/4" x 100' HEW 4113CT MM NPT BR NR	81.0 (36.8)
1 1/2" HOSES		
CP240024CABA	1 1/2" x 2' HEW 4113CT MM NPT BR NR	1.7 (0.8)
CP240108CABA	1 1/2" x 9' HEW 4113CT MM NPT BR NR	11.0 (5.0)
CP240120CABA	1 1/2" x 10' HEW 4113CT MM NPT BR NR	12.0 (5.5)
CP240600CABA	1 1/2" x 50' HEW 4113CT MM NPT BR NR	51.0 (23.2)
CP240720CABA	1 1/2" x 60' HEW 4113CT MM NPT BR NR	61.0 (27.8)
CP240780CBBA	1 1/2" x 65' HEW 4113CT MF NPT BR NR	66.0 (30.0)
CP240792CABA	1 1/2" x 66' HEW 4113CT MM NPT BR NR	67.0 (30.5)
CP240840CABA	1 1/2" x 70' HEW 4113CT MM NPT BR NR	71.0 (32.3)
CP240900CABA	1 1/2" x 75' HEW 4113CT MM NPT BR NR	76.0 (34.5)
CP241020CABA	1 1/2" x 85' HEW 4113CT MM NPT BR NR	85.0 (38.6)
CP241200CABA	1 1/2" x 100' HEW 4113CT MM NPT BR NR	100.0 (45.5)
CP241200CBBA	1 1/2" x 100' HEW 4113CT MF NPT BR NR	100.0 (45.5)

MODEL NO.	DESCRIPTION	SHIPPING WEIGHT LBS (KG)
CP240420CABA	1 1/2" x 35' HEW 4113CT MM NPT BR NR	36.0 (16.4)
CP240684CABA	1 1/2" x 57' HEW 4113CT MM NPT BR NR	49.0 (22.3)
CP240780CABA	1 1/2" x 65' HEW 4113CT MM NPT BR NR	66.0 (30.0)
CP241368CABA	1 1/2" x 114' HEW 4113CT MM NPT BR NR	98.0 (44.5)
CP241800CABA	1 1/2" x 150' HEW 4113CT MM NPT BR NR	129.0 (58.6)
2" HOSES		
CP320120CABA	2" x 10' HEW 4113CT MM NPT BR NR	16.0 (7.3)
CP320134CABA	2" x 11.17' HEW 4113CT MM NPT BR NR	13.4 (6.1)
CP320144CABA	2" x 12' HEW 4113CT MM NPT BR NR	19.0 (8.6)
CP320180CABA	2" x 15' HEW 4113CT MM NPT BR NR	23.0 (10.5)
CP320197CABA	2" x 16' 5" HEW 4113CT MM NPT BR NR	24.0 (10.9)
CP320216CABA	2" x 18' HEW 4113CT MM NPT BR NR	26.0 (11.8)
CP320240CABA	2" x 20' HEW 4113CT MM NPT BR NR	29.0 (13.2)
CP320420CABA	2" x 35' HEW 4113CT MM NPT BR NR	49.0 (22.3)
CP320480CABA	2" x 40' HEW 4113CT MM NPT BR NR	55.0 (25.0)
CP320564CABA	2" x 47' HEW 4113CT MM NPT BR NR	56.4 (25.6)
CP320600CABA	2" x 50' HEW 4113CT MM NPT BR NR	68.0 (30.9)
CP320600CBBA	2" x 50' HEW 4113CT MF NPT BR NR	68.0 (30.9)
CP320684CABA	2" x 57' HEW 4113CT MM NPT BR NR	68.4 (31.1)
CP320720CABA	2" x 60' HEW 4113CT MM NPT BR NR	81.0 (36.8)
CP320792CABA	2" x 66' HEW 4113CT MM NPT BR NR	89.0 (40.5)
CP320900CABA	2" x 75' HEW 4113CT MM NPT BR NR	101.0 (45.9)
2 1/2" HOSES		
CP400096CABA	2 1/2" x 8' HEW 4113CT MM NPT BR NR	19.0 (8.6)
CP400108CABA	2 1/2" x 9' HEW 4113CT MM NPT BR NR	20.0 (9.1)
CP400120CBBA	2 1/2" x 10' HEW 4113CT MF NPT BR NR	22.0 (10.0)
CP400120CABA	2 1/2" x 10' HEW 4113CT MM NPT BR NR	22.0 (10.0)
CP400144CABA	2 1/2" x 12' HEW 4113CT MM NPT BR NR	25.0 (11.4)
CP400156CABA	2 1/2" x 13' HEW 4113CT MM NPT BR NR	27.0 (12.3)
CP400192CABA	2 1/2" x 16' HEW 4113CT MM NPT BR NR	32.0 (14.5)
CP400197CABA	2 1/2" x 16' 5" HEW 4113CT MM NPT BR NR	33.0 (15.0)
CP400420CABA	2 1/2" x 35' HEW 4113CT MM NPT BR NR	64.0 (29.1)
CP400480CABA	2 1/2" x 40' HEW 4113CT MM NPT BR NR	73.0 (33.2)
CP400600CBBA	2 1/2" x 50' HEW 4113CT MF NPT BR NR	90.0 (40.9)
CP400600CABA	2 1/2" x 50' HEW 4113CT MM NPT BR NR	90.0 (40.9)
CP400660CABA	2 1/2" x 55' HEW 4113CT MM NPT BR NR	98.0 (44.5)
CP400720CABA	2 1/2" x 60' HEW 4113CT MM NPT BR NR	106.0 (48.2)
CP400084CABA	2 1/2" x 7' HEW 4113CT MM NPT BR NR	17.0 (7.7)
CP400118CABA	2 1/2" x 9' 3" HEW 4113CT MM NPT BR NR	20.0 (9.1)



WARNING: Cancer and Reproductive Harm - www.P65Warnings.ca.gov

4113CT Permanent

4113CT Cold Temperature Hose Permanent Fitting aviation fueling hose recommended for all types of riser deck, reel, and hydrant hose applications.

MODEL NO.	DESCRIPTION	SHIPPING WEIGHT LBS (KG)
CP400132CABA	2 1/2" x 11' HEW 4113CT MM NPT BR NR	34.0 (15.5)
CP400180CABA	2 1/2" x 15' HEW 4113CT MM NPT BR NR	30.0 (13.6)
CP400240CABA	2 1/2" x 20' HEW 4113CT MM NPT BR NR	39.0 (17.7)
CP400684CABA	2 1/2" x 57' HEW 4113CT MM NPT BR NR	100.0 (45.5)
CP401200CBBA	2 1/2" x 100' HEW 4113CT MF NPT BR NR	174.0 (79.1)
3" HOSES		
CP480096CABA	3" x 8' HEW 4113CT MM NPT BR NR	28.0 (12.7)
CP480108CABA	3" x 9' HEW 4113CT MM NPT BR NR	31.0 (14.1)
CP480120CABA	3" x 10' HEW 4113CT MM NPT BR NR	34.0 (15.5)
CP480132CABA	3" x 11' HEW 4113CT MM NPT BR NR	36.0 (16.4)
CP480144CABA	3" x 12' HEW 4113CT MM NPT BR NR	39.0 (17.7)
CP480168CABA	3" x 14' HEW 4113CT MM NPT BR NR	44.0 (20.0)
CP480180CABA	3" x 15' HEW 4113CT MM NPT BR NR	46.0 (20.9)
CP480240CABA	3" x 20' HEW 4113CT MM NPT BR NR	59.0 (26.8)
CP480360CBBA	3" x 30' HEW 4113CT MF NPT BR NR	85.0 (38.6)
CP480600CBBA	3" x 50 FT HEW 4113CT MF NPT BR NR	136.0 (61.8)
CP480600CABA	3" x 50' HEW 4113CT MM NPT BR NR	136.0 (61.8)
CP480720CABA	3" x 60' HEW 4113CT MM NPT BR NR	162.0 (73.6)

Construction

Tube	Black nitrile synthetic rubber
Cover	Black neoprene static dissipating/static conductive synthetic rubber (wrapped finish)
Reinforcement	Spiral-plied (4) synthetic fabric and one nylon breaker
Couplings	Permanent brass internally expanded fittings - male and female NPT (swivel nut) Reusable 4-bolt aluminum clamp fittings - male and female, NPT and BSP threads - all females have swivel nuts - available with brass, tin plated brass, and stainless inserts

Order Guide (Ex. CP320600CABA)

AVIATION HOSE SIZE - CPSS

3/4" = CP12	2" = CP32
1" = CP16	2 1/2" = CP40
1 1/4" = CP20	3" = CP48
1 1/2" = CP24	4" = CP64

HOSE LENGTH (IN INCHES) - LLLL

0600 = 50 feet 0 inches
0606 = 50 feet 6 inches

AVIATION HOSE - H or J

H = 4113 Aviation Hose
J = 5500 JacRiser Hose

FITTING STYLE - S

A = Male x Male NPT Not Reusable
B = Male x Female NPT not Reusable
C = Female x Female NPT Not Reusable
D = Male x Male NPT Reusable
E = Male x Female NPT Reusable
F = Female x Female NPT Reusable
J = Male x Male BSP Reusable
K = Male x Female BSP Reusable
L = Female x Female BSP Reusable
S = Special (See Note 1)

FITTING BRAND - F

A = Internal Expansion Permanent (stainless steel only)
B = Dixon/UMI Internal Expansion (Permanent Brass Insert)
D = Dixon Swaged
E = Dixon Reusable
F = Elaflex Reusable
G = Roman Seliger Reusable

INSERT MATERIAL - M

A = Brass
B = Stainless Steel
D = Tin-Plated Brass
F = Carbon Steel

OVERALL LENGTH - O

For all sizes except CP64, if "O" is present, LLLL = OAL
For CP64 only, if blank, LLLL = OAL
For CP64 only, if "C" present, LLLL = Cut Length

Technical Data for 4113CT Cold Temperature Fueling Hose

Size	ID		NOM OD		MAX WP		WEIGHT	
	MM	IN	MM	PSI	MPA	LB/FT	KG/M	
1"	25	1.457	37	300	2.07	0.54	0.80	
1 1/4"	32	1.732	44	300	2.07	0.67	1.00	
1 1/2"	38	2.008	51	300	2.07	0.81	1.20	
2"	50	2.598	66	300	2.07	1.28	1.90	
2 1/2"	63	3.110	79	300	2.07	1.61	2.40	
3"	75	3.583	91	300	2.07	1.88	2.80	

Couplings

Permanent Brass	Internally expanded fittings (standard for 1" and 3" ID) - male NPT and female NPS (swivel nut)
Crimped on Stainless	Male NPT (zinc-plated ferrules) standard for 4" ID hose assemblies. Internally expanded brass male NPT and NPS are also available.
Reusable 4-Bolt	Aluminum clamp fittings - male and female, NPT and BSP threads - all females have swivel nuts - available with brass, tin-plated brass and stainless inserts.

Protective Coils

9746	2" Banding Coil, White
9744	3" Banding Coil, White
9774	4" Banding Coil, White

NOTE:

If special, the next two digits will be used sequentially first using numbers (0-9) then using Alpha (A-Z). Special fittings or special materials will be described in the fab/shipping instructions section of the factory order. See separate assembly drawing for each special assembly number.

5500 JacRiser

Used in riser connection of aviation refuelers, hydrant cart servicers and tank farm connections.

- Used for commercial and private aircraft
- Resistant to jet fuel and higher aromatic aviation gasolines
- Premium fueling and defueling hose designed to achieve more than twice the cycle flexing capabilities (124000 plus cycles)
- Meets EI 1529, 7th Edition, 2014 and European Standard EN ISO 1825 (2011), Type E, Grade 2, NPFA 407
- Suitable for full vacuum service and high flex applications
- Designed for flexible connection between hydrant cart or refueler chassis and adjustable riser platform
- Functional in temperatures -40°F to 180°F (-40°C to 82°C)
- All aviation hose assemblies are 100% hydrostatic tested to 600 PSI and inspected for electrical continuity.
- Every hose receives a unique serial number and test certificate.

Swaged on Stainless Male NPT - 4 Inch ID Hoses

MODEL NO.	DESCRIPTION	SHIPPING WEIGHT LBS (KG)
CP640092JADB	4" x 92" OAL JAC 5500 MXM NPT SS NR 51	(23.2)
CP640102JADB	4" x 102" OAL JAC 5500 MXM NPT SS NR55	(25.0)
CP640132JADB	4" x 11' OAL JAC 5500 MXM NPT SS NR 66	(30.0)
CP640108JADB	4" x 9' OAL JAC 5500 MXM NPT SS NR 57	(25.9)
CP640420JADB	4" x 35' OAL JAC 5500 MXM NPT SS NR171	(77.7)
CP640087JADB	4" x 87" OAL JAC 5500 MXM NPT SS NR 50	(22.7)
CP640128JADB	4" x 128" OAL JAC 5500 MXM NPT SS NR65	(29.5)
CP640126JADB	4" x 10'6" OAL JAC 5500 MXM NPT SS NR 64	(29.1)
CP640110JADB	4" x 110" OAL JAC 5500 MXM NPT SS NR54	(24.5)

Internally Expanded Brass Male NPT - 1-1/2, 2, 2-1/2 and 3 Inch ID Hoses

MODEL NO.	DESCRIPTION	SHIPPING WEIGHT LBS (KG)
CP240480JABA1-1/2" X 40'	5500 MXM NPT BR NR	54 (24.5)
CP240400JABA1-1/2" X 70'	5500 MXM NPT BR NR	94 (42.6)
CP320480JABA2" x 40'	JAC 5500 MXM NPT BR NR	67 (30.4)
CP320900JABA2" x 75'	JAC 5500 MXM NPT BR NR	123 (55.8)
CP400120JABA2-1/2" X 10'	5500 MXM NPT BR NR	25 (11.3)
CP400360JABA2-1/2" X 30'	5500 MXM NPT BR NR	69 (31.3)
CP480180JABA3" x 15'	JAC 5500 MXM NPT BR NR	53 (24.0)
CP480300JABA3" x 25'	JAC 5500 MXM NPT BR NR	83 (37.6)
CP480144JABA3" x 12'	JAC 5500 MXM NPT BR NR	44 (20.0)
CP480096JABA3" x 8'	JAC 5500 MXM NPT BR NR	32 (14.5)

Construction

Tube	Black nitrile synthetic rubber
Cover	Black neoprene static dissipating/static conductive synthetic rubber (wrapped finish)
Reinforcement	Spiral-plyed (4) synthetic fabric and one nylon breaker with dual wire helix construction



Above are examples of existing part numbers. Husky can build any hose to any length with a variety of fittings. Contact Husky for additional information if you do not see an assembly that matches your needs.



WARNING: Cancer and Reproductive Harm - www.P65Warnings.ca.gov

5500 JacRiser

Used in riser connection of aviation refuelers, hydrant cart servicers and tank farm connections.

Dimensions and System Options

Available in these Sizes

Size	ID		NOM OD		MAX WP		BEND RADIUS		WEIGHT	
	MM	IN	MM	IN	PSI	MPA	IN	MM	LB/FT	KG/M
1-1/2"	38	2.18	55.4	300	2.07	6.0	152	1.27	1.89	
2"	50	2.756	69.8	300	2.07	8.0	203	1.74	2.59	
2-1/2"	63.5	3.22	81.9	300	2.07	10.0	254	2.13	3.17	
3"	75	3.82	98.6	300	2.07	12.0	305	2.93	4.36	
4"	102	4.97	126.2	300	2.07	16.0	406	4.40	6.55	

Couplings

Permanent Brass	Internally expanded fittings (standard for 2" and 3" ID) - male NPT and female NPS (swivel nut)
Swaged on Stainless	Male NPT (zinc-plated ferrules) standard for 4" ID hose assemblies. Internally expanded brass male NPT and NPS are also available.
Reusable 4-Bolt	Aluminum clamp fittings - male and female, NPT and BSP threads - all females have swivel nuts - available with brass, tin-plated brass and stainless inserts.

Protective Coils

9746	2" Banding Coil, White
9744	3" Banding Coil, White
9774	4" Banding Coil, White
9793	3" Banding Coil, Orange



Order Guide (Ex. CP320600JABA)

AVIATION HOSE SIZE - CPSS

3/4" = CP12	2" = CP32
1" = CP16	2 1/2" = CP40
1 1/4" = CP20	3" = CP48
1 1/2" = CP24	4" = CP64

HOSE LENGTH (IN INCHES) - LLLL

0600 = 50 feet 0 inches
0606 = 50 feet 6 inches

AVIATION HOSE - H or J

H = 4113 Aviation Hose
J = 5500 JacRiser Hose

NOTE:

If special, the next two digits will be used sequentially first using numbers (0-9) then using Alpha (A-Z). Special fittings or special materials will be described in the fab/shipping instructions section of the factory order. See separate assembly drawing for each special assembly number.

FITTING STYLE - S

A = Male x Male NPT Not Reusable
B = Male x Female NPT not Reusable
C = Female x Female NPT Not Reusable
D = Male x Male NPT Reusable
E = Male x Female NPT Reusable
F = Female x Female NPT Reusable
J = Male x Male BSP Reusable
K = Male x Female BSP Reusable
L = Female x Female BSP Reusable
S = Special (See Note 1)

FITTING BRAND - F

A = Internal Expansion Permanent (stainless steel only)
B = Dixon/UMI Internal Expansion (Permanent Brass Insert)
D = Dixon Swaged
E = Dixon Reusable
F = Elaflex Reusable
G = Roman Seliger Reusable

INSERT MATERIAL - M

A = Brass
B = Stainless Steel
D = Tin-Plated Brass
F = Carbon Steel

OVERALL LENGTH - O

For all sizes except CP64, if "0" is present, LLLL = OAL
For CP64 only, if blank, LLLL = OAL
For CP64 only, if "C" present, LLLL = Cut Length

Twin 1/4-Inch

Used in connection of deadman control during aircraft servicing.

- Integral assembly for use with the deadman control valve
- Vertically braided textile
- Twinned 1/4" diameter red and green hose is vulcanized.
- Highly resistant to oil
- Available in bulk or with crimped-on male or female swivel fittings

Specifying Information

MODEL NO.	DESCRIPTION	SHIPPING WEIGHT LBS. (KG)
9742	Hose, A, 1/4" Deadman Twinline	0.20 (0.09)

Spring Guards

MODEL NO.	DESCRIPTION	SHIPPING WEIGHT LBS.
9878	1/4" x 50' Dead MXF with spring guard	11.25

Construction

Tube	Nitrile synthetic rubber, RMA Class A
Color	One red hose, one green hose



Twin 1/4-Inch

Used in connection of deadman control during aircraft servicing.

Dimensions and System Options

Available in these Sizes

ID (IN)	ID (MM)	SPIRALS	OD (IN)	OD (MM)	LB/FT	KG/M
1/4	6.4	2	34/64	13.5	0.19	0.28

Fittings

Crimped on male or female swivels.

Options

Available in cut lengths assembled or in bulk (approx. 700 ft. per reel).

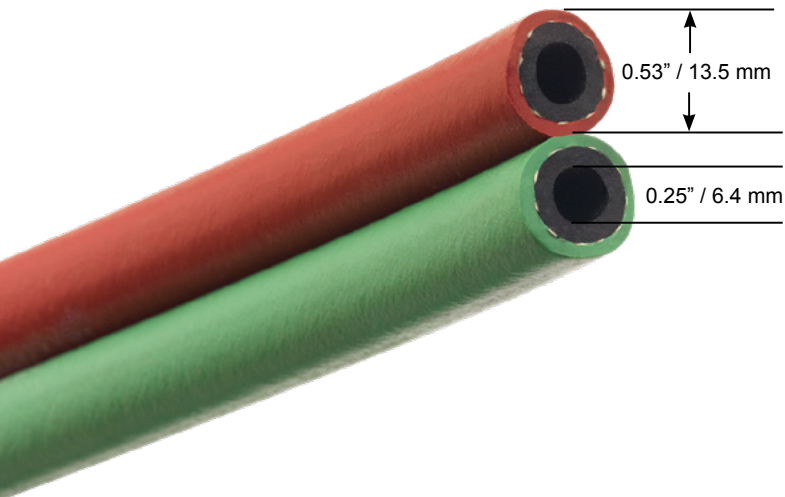

Twin $\frac{3}{8}$ -Inch

Used in connection of aircraft servicers and airport hydrants and sensing control systems.

- Integral assembly to connect aircraft servicers to airport hydrant reference and sensing control systems
- Vertically braided textile
- Twinned $\frac{3}{8}$ " diameter yellow and green hose is vulcanized.
- Highly resistant to oil
- Available in bulk or with crimped-on male or female swivel fittings

Specifying Information

MODEL NO.	DESCRIPTION	SHIPPING WEIGHT LBS. (KG)
9743	Hose, A, $\frac{3}{8}$ " Sensing Hose Twinline	0.29 (0.13)

Construction

Tube	Nitrile synthetic rubber, RMA Class A
Color	One yellow, one green hose



Twin $3/8$ -Inch

Used in connection of aircraft servicers and airport hydrants and sensing control systems.

Dimensions and System Options

Available in these Sizes

ID (IN)	ID (MM)	SPIRALS	OD (IN)	OD (MM)	LB/FT	KG/M
$3/8$	9.5	2	21/32	16.6	0.29	0.43

Fittings

Crimped on male or female swivels.

Options

Available in cut lengths assembled or in bulk (approx. 700 ft. per reel).

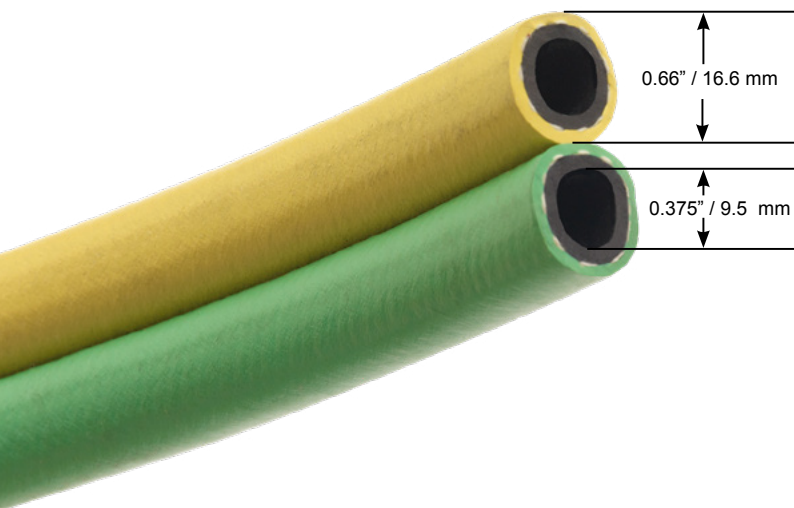



Aviation Nozzles

Osprey Nozzle

Automatic shut-off nozzle for over-the-wing fueling of aircraft.

- Specifically designed for business and private over-the-wing aviation fueling
- Automatic shut-off when wing tanks are full
- Easy to remove and clean fuel 100 mesh SS fuel filter assembly
- Nozzle comes with red full grip guard to identify use only with aviation fuel or black full grip guard for jet fuel application if desired.
- Complies with IE1540 and NPA 407

Osprey Nozzle with NPT

MODEL NO.	DESCRIPTION	SHIPPING WEIGHT LBS. (KG)
1149812N [^]	without Hold Open Clip and Spout Bushing, with Waffle Splash Guard and mesh filter	4.6 (2.0)
		[^] NOT LISTED

Osprey Nozzle with BSPP

MODEL NO.	DESCRIPTION	SHIPPING WEIGHT LBS. (KG)
1149840N [^]	without Hold Open Clip and Spout Bushing, with Waffle Splash Guard and mesh filter	4.6 (2.0)
		[^] NOT LISTED

Construction

Body	Aluminum
Seals	Fluorocarbon
Packing	Double o-ring seal protected by fiber reinforced Teflon [®]
Lever	One piece contoured steel
Inlet	1" / 25.4 mm NPT and BSPP

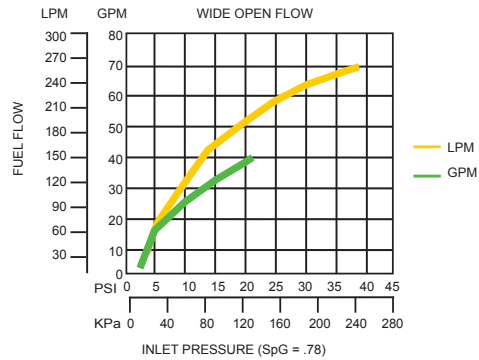

Osprey Nozzle

Automatic shut-off nozzle for over-the-wing fueling of aircraft.

Dimensions and System Options

Swivels

MODEL NO.	DESCRIPTION
008517	1" M x 1" F NPT Single Plane Swivel
004860	1" M x 1" F NPT Multi-Plane High Flow Swivel
003306	1" M x 1" F BSPP Multi-Plane Swivel
006949	1" M x 1" F BSPP Multi-Plane High Flow Swivel

Accessories

MODEL NO.	DESCRIPTION
011817	Electrical Grounding Plug
012141	Osprey Spout Assembly Kit
011946	Spout Cap Assembly
012148	Strainer BSP Kit
012143	Strainer NPT Kit

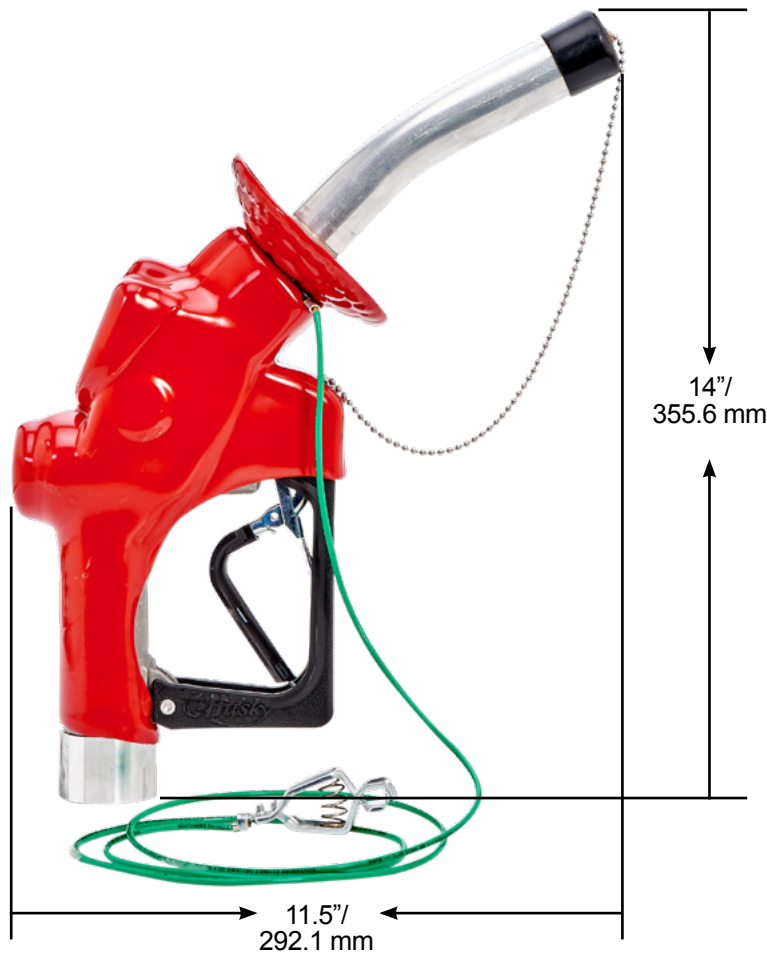

Falcon Manual Nozzle

Manual shut-off nozzle for over-the-wing fueling of aircraft.

- Specifically designed for business and private over-the-wing aviation fueling
- Spout can be removed by loosening nut.
- 100 mesh stainless steel fuel filter to prevent dust and debris from entering the fuel tank; located in the spout for easy removal and cleaning
- Complies with IE 1540 and NPA 407
- Black jet fuel nozzle with optional duck bill spout or round spout
- Red aviation gas nozzle with round spout
- Available with the following inlets:
 1-1/2" (38mm) Female NPT
 1-1/2" (38mm) Female BSPP
 1-1/4" (32mm) Female NPT
 1-1/4" (32mm) Female BSPP



Falcon Nozzle with NPT

MODEL NO.	DESCRIPTION	SHIPPING WEIGHT LBS. (KG)
12090218N [^]	without Hold Open Clip, with Jet Black, Duck Bill Spout, and 1½ FNPT (38mm) Inlet Inline Swivel	5.0 (2.3)
12090219N [^]	without Hold Open Clip, with Jet Black, Duck Bill Spout, and 1¼ FNPT (32mm) Inlet Inline Swivel	5.0 (2.3)
13734218N [^]	without Hold Open Clip, with Jet Black, Round Spout, and 1½ FNPT (38mm) Inlet Inline Swivel	5.0 (2.3)
13734219N [^]	without Hold Open Clip, with Jet Black, Round Spout, and 1¼ FNPT (32mm) Inlet Inline Swivel	5.0 (2.3)
13739218N [^]	without Hold Open Clip, with Aviation Red, Round Spout, and 1½ FNPT (38mm) Inlet Inline Swivel	5.0 (2.3)
13739219N [^]	without Hold Open Clip, with Aviation Red, Round Spout, and 1¼ FNPT (32mm) Inlet Inline Swivel	5.0 (2.3)

[^] NOT LISTED

Falcon Nozzle with BSPP

MODEL NO.	DESCRIPTION	SHIPPING WEIGHT LBS. (KG)
12090216N [^]	without Hold Open Clip, with Jet Black, Duck Bill Spout, and 1½ FBSP (38mm) Inlet Inline Swivel	5.0 (2.3)
12090217N [^]	without Hold Open Clip, with Jet Black, Duck Bill Spout, and 1¼ FBSP (32mm) Inlet Inline Swivel	5.0 (2.3)
13734216N [^]	without Hold Open Clip, with Jet Black, Round Spout, and 1½ FBSP (38mm) Inlet Inline Swivel	5.0 (2.3)
13734217N [^]	without Hold Open Clip, with Jet Black, Round Spout, and 1¼ FBSP (32mm) Inlet Inline Swivel	5.0 (2.3)
13739216N [^]	without Hold Open Clip, with Aviation Red, Round Spout, and 1½ FBSP (38mm) Inlet Inline Swivel	5.0 (2.3)
13739217N [^]	without Hold Open Clip, with Aviation Red, Round Spout, and 1¼ FBSP (32mm) Inlet Inline Swivel	5.0 (2.3)

[^] NOT LISTED

Construction

Body	Aluminum
Seals	Fluorocarbon
Packing	Double o-ring seal protected by fiber reinforced Teflon®
Lever	One piece contoured steel

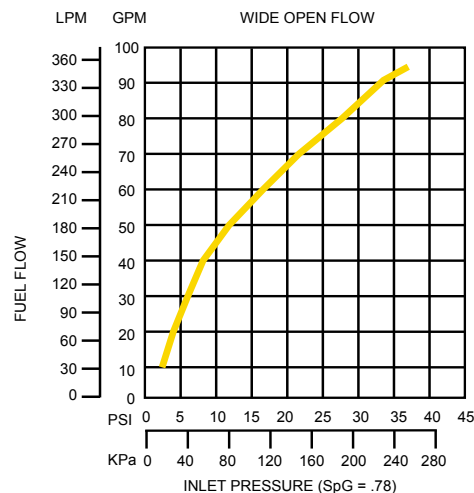

Falcon Manual Nozzle

Manual shut-off nozzle for over-the-wing fueling of aircraft.

Dimensions and System Options

Accessories

MODEL NO.	DESCRIPTION
012946	Jet Oval Manual Spout Kit
012948	Aviation Round Manual Spout Kit
013476	Interlock Hook Assembly
014204	Black Jet Fuel Oval Spout Cap Assembly
014205	Black Jet Fuel Round Spout Cap Assembly
014206	Red Aviation Fuel Round Spout Cap Assembly

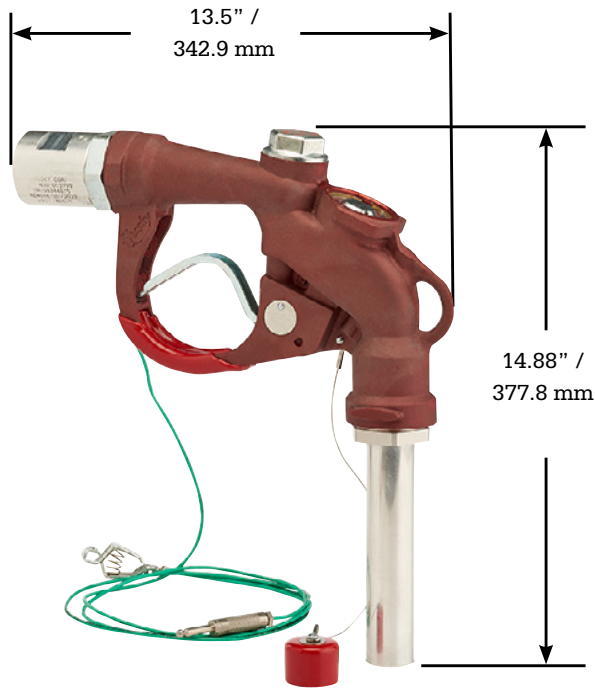

Falcon Manual Nozzle

Quick Disconnect

Manual shut-off nozzle for over-the-wing fueling of aircraft.

- Specifically designed for business and private over-the-wing aviation fueling
- Quick disconnect spout feature for easy removal
- 100 mesh stainless steel fuel filter to prevent dust and debris from entering the fuel tank; located in the spout for easy removal and cleaning
- Complies with IE 1540 and NPA 407
- Black jet fuel nozzle with optional duck bill spout or round spout
- Red aviation gas nozzle with round spout.
- Available with the following inlets:
 1-1/2" (38mm) Female NPT
 1-1/2" (38mm) Female BSPP
 1-1/4" (32mm) Female NPT
 1-1/4" (32mm) Female BSPP



Falcon Nozzle with NPT

MODEL NO.	DESCRIPTION	SHIPPING WEIGHT LBS. (KG)
13731218N^	without Hold Open Clip, with Jet Black, Duck Bill Spout, and 1½ FNPT (38mm) Inlet Inline Swivel	5.0 (2.3)
13731219N^	without Hold Open Clip, with Jet Black, Duck Bill Spout, and 1¼ FNPT (32mm) Inlet Inline Swivel	5.0 (2.3)
13736218N^	without Hold Open Clip, with Jet Black, Round Spout, and 1½ FNPT (38mm) Inlet Inline Swivel	5.0 (2.3)
13736219N^	without Hold Open Clip, with Jet Black, Round Spout, and 1¼ FNPT (32 mm) Inlet Inline Swivel	5.0 (2.3)
13742218N^	without Hold Open Clip, with Aviation Red, Round Spout, and 1½ FNPT (38mm) Inlet Inline Swivel	5.0 (2.3)
13742219N^	without Hold Open Clip, with Aviation Red, Round Spout, and 1¼ FNPT (32mm) Inlet Inline Swivel	5.0 (2.3)

^ NOT LISTED

Falcon Nozzle with BSPP

MODEL NO.	DESCRIPTION	SHIPPING WEIGHT LBS. (KG)
13731216N^	without Hold Open Clip, with Jet Black, Duck Bill Spout, and 1½ FBSP (38mm) Inlet Inline Swivel	5.0 (2.3)
13731217N^	without Hold Open Clip, with Jet Black, Duck Bill Spout, and 1¼ FBSP (32mm) Inlet Inline Swivel	5.0 (2.3)
13736216N^	without Hold Open Clip, with Jet Black, Round Spout, and 1½ FBSP (38mm) Inlet Inline Swivel	5.0 (2.3)
13736217N^	without Hold Open Clip, with Jet Black, Round Spout, and 1¼ FBSP (32mm) Inlet Inline Swivel	5.0 (2.3)
13742216N^	without Hold Open Clip, with Aviation Red, Round Spout, and 1½ FBSP (38mm) Inlet Inline Swivel	5.0 (2.3)
13742217N^	without Hold Open Clip, with Aviation Red, Round Spout, and 1¼ FBSP (32mm) Inlet Inline Swivel	5.0 (2.3)

^ NOT LISTED

Construction

Body	Aluminum
Seals	Fluorocarbon
Packing	Double o-ring seal protected by fiber reinforced Teflon®
Lever	One piece contoured steel

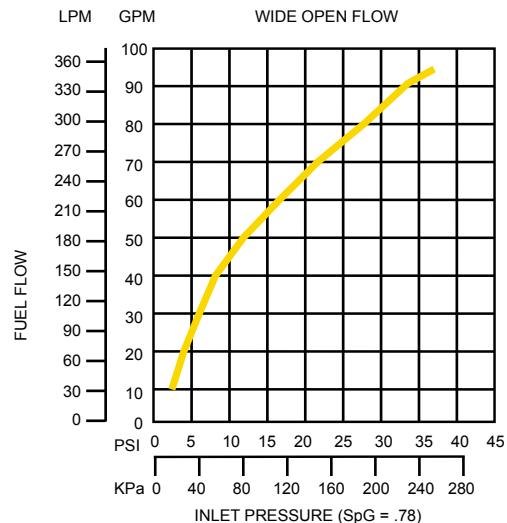

Falcon Manual Nozzle

Quick Disconnect

Manual shut-off nozzle for over-the-wing fueling of aircraft.

Dimensions and System Options

Accessories

MODEL NO.	DESCRIPTION
012947	Jet Oval Quick Disconnect Manual Spout Kit
012949	Aviation Quick Disconnect Round Manual Spout Kit
013476	Interlock Hook Assembly
014204	Black Jet Fuel Oval Spout Cap Assembly
014205	Black Jet Fuel Round Spout Cap Assembly
014206	Red Aviation Fuel Round Spout Cap Assembly

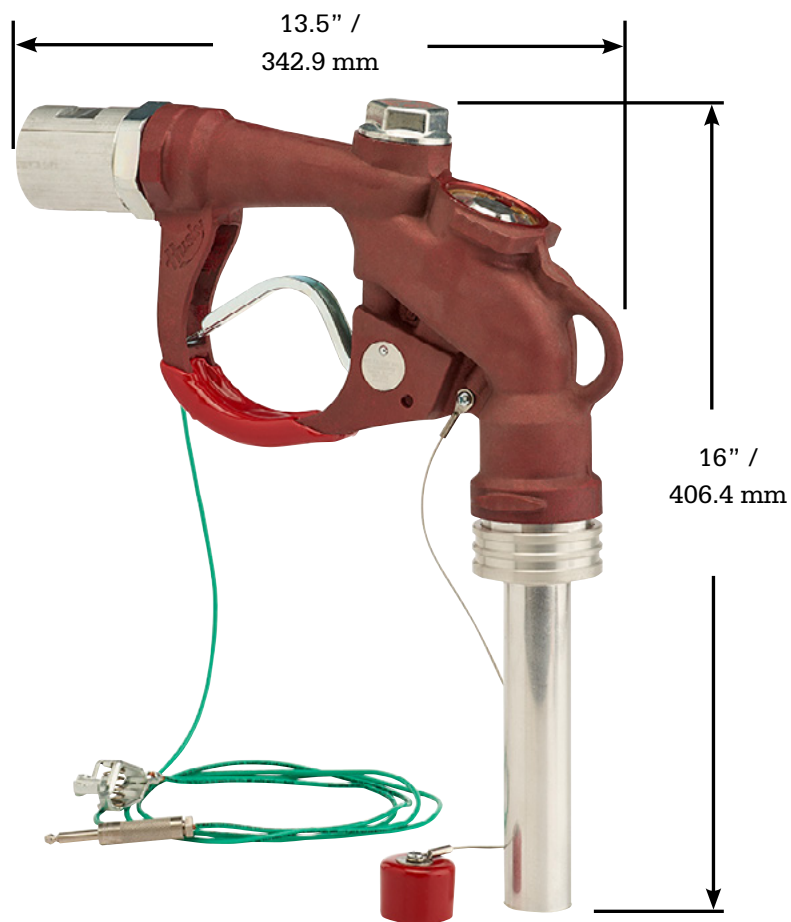



Parts & Accessories



Aviation Couplings

In order to meet and comply with EI 1529 and EN ISO 1825 specifications, all Hewitt aviation hoses are supplied with either permanent or reusable couplings.

Permanent Couplings

- Internally expanded brass and stainless fittings, stainless available upon request
- NPT male and NPSH female threads (swivel nuts on female fittings)
- Swaged stainless male NPT insert with zinc-plated ferrule (Standard on 4" only)
- 4" internally expanded brass male NPT and NPSH female inserts are available as options.

Reusable Couplings

- 4-bolt aluminum clamps with brass, tin-plated brass or stainless inserts
- NPT male, NPSH female, BSP male and BSP female threads (swivel nuts on female fittings)
- Reusable fittings are available as separate items on request.

Adaptors

- Any of these fittings can be supplied with adaptors such as Cam & Groove and threaded flanges
- Dixon "Boss" Cam & Groove fittings are USA made. Imported versions are available.
- Stainless, brass, and aluminum step-up bushings
- Stainless, carbon steel and aluminum threaded flanges



Spiral Hose Protectors

Used to extend hose life, prevent kinking and reduce abrasion.

- Excellent for extending hose life, preventing kinking on deck and reel hoses, and reducing abrasion to hose cover.
- Installing coils at hose reel outlet riser will prevent hose collapse and maintain high fuel flow.
- Covers from 2 to 4 feet.
- Available to fit 1" to 4" ID S hose.
- Easily installed by factory or in the field.
- Standard white hose coils available from stock.
- Special colors and extra tough urethane hose protector coil available upon request.

Specifying Information

MODEL NO.	DESCRIPTION	SHIPPING WEIGHT FT/LBS.
9746	2" Banding Coil, White	0.6385
9744	3" Banding Coil, White	1.2260
9774	4" Banding Coil, White	1.5710
9793	3" Banding Coil, Orange	1.2260

Construction

Material	PVC
----------	-----



Rev. 8/12

Aviation Swivels

High volume swivels for over-the-wing fueling of aircraft.

- Prevents kinking and twisting of hose
- Unique stainless steel ball bearing design provides easier joint movement during high pressure applications.
- Easier to angle the nozzle into fill openings



NPT x BSPP

MODEL NO.	DESCRIPTION	SHIPPING WEIGHT LBS. (KG)
012799	1½" x 1½" BSPP Long Thread Single Plane Swivel	1.4 (.65)
012800	1¼" x 1½" BSPP Long Thread Single Plane Swivel	1.4 (.65)

BSPP x BSPP

MODEL NO.	DESCRIPTION	SHIPPING WEIGHT LBS. (KG)
013517	1¼" F x 1½" M Long Thread Single Plane Swivel	1.4 (.65)
013518	1½" F x 1½" M Long Thread Single Plane Swivel	1.4 (.65)

Construction

Body	Aluminum
Seals	Fluorocarbon

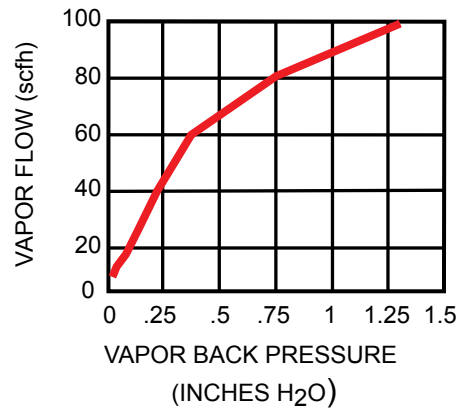

Aviation Swivels

High volume swivels for over-the-wing fueling of aircraft.

Dimensions



Falcon Spouts

Spout assemblies.

- Replacement spout assemblies for nozzles that attach to the nozzle with a nut
- Replacement spout assemblies for nozzles that attach to a nozzle with a quick disconnect
- Duck bill spout assemblies for use with jet fuel only
- Round spout assemblies for use with both aviation and jet fuel

Falcon Nut Spout Assemblies

MODEL NO.	DESCRIPTION	SHIPPING WEIGHT LBS (KG)
012946	Duck Bill Spout Assembly for Jet Fuel	.6 (.27)
012948	Round Spout Assembly for Aviation and Jet Fuel	.5 (.23)

Falcon Quick Disconnect Spout Assemblies

MODEL NO.	DESCRIPTION	SHIPPING WEIGHT LBS (KG)
012947	Duck Bill Spout Assembly for Jet Fuel	.5 (.23)
012949	Round Spout Assembly for Aviation and Jet Fuel	.5 (.23)

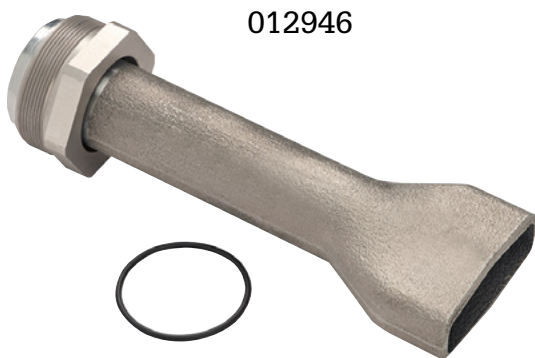

Falcon Nut Spout Assembly

Falcon Quick Disconnect Spout Assembly



Falcon Spouts

Spout assemblies.

Dimensions

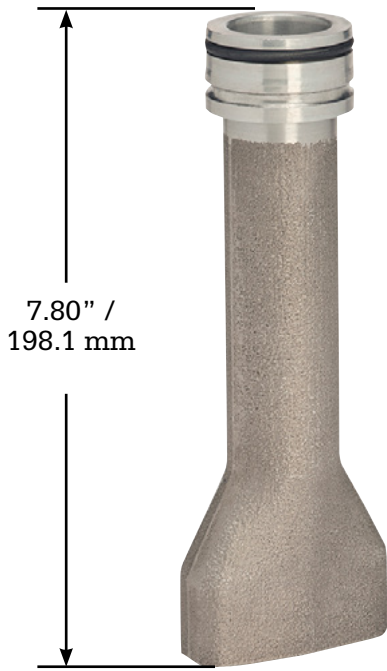

012946
012947

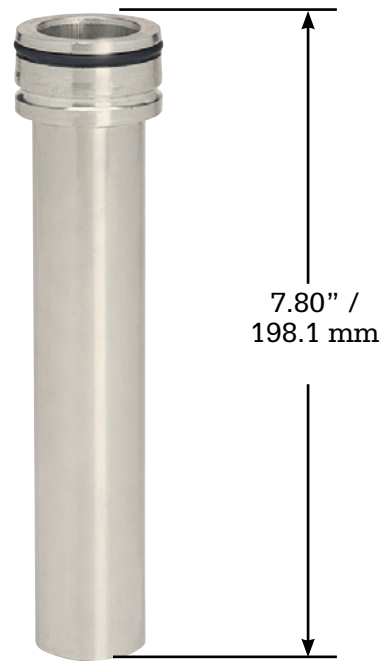

012948
012949

Aviation NPT Strainer

Strainer for over-the-wing fueling of aircraft.

- Easy to remove and clean fuel 100 mesh SS fuel filter assembly
- Suitable for aviation fueling and other compatible fluids
- Complies with IE1540 and NPA 407
- Simple Male NPT x Female NPT strainer adaptor for multipurpose uses in fluid transfer.

Strainer

MODEL NO.	DESCRIPTION	SHIPPING WEIGHT LBS. (KG)
014024	3/4" NPT F x 3/4" NPT	1.5 (.8)

Construction

Body	Aluminum
Strainer	Stainless Steel
Inlet	3/4" (19mm) NPT threads



Aviation NPT Strainer

Strainer for over-the-wing fueling of aircraft.

Dimensions





Roman Seliger Catalog



Loading Arms

SGA Loading Arm

The new Roman Seliger SGA Loading Arm is a safe and easy arrangement for transfer of liquid and gas products to tanker cars, tanker trucks, and vessels. This simple loading arm supports a loading transfer hose and allows for easy and safe movement of the transfer hose to and from the loading vehicle or car from a stowed position. Operator is not required to lift the hose. The loading arm supports all the weight. Any type of hose can be used with the SGA loading arm along with dry breaks, breakaways, or special attachment couplings.

- Special flexible joint mechanism makes it impossible for the loading arm radius to go below the minimum safe bending radius of the hose assembly and extends the life of hose.
- Eliminates wear and tear on hose cover and reduces operator injuries
- Special spring or gas operated mechanisms can be added to allow operator to rise and lower arm with minimal effort.
- Lower maintenance time and cost
- Lower risk of damage
- Suitable for heavy or heated hoses and fittings
- Maximum transfer rate
- RS system meets highest safety requirements.
- Each SGA hose loading arm is made to measure for a particular application and conditions of use.

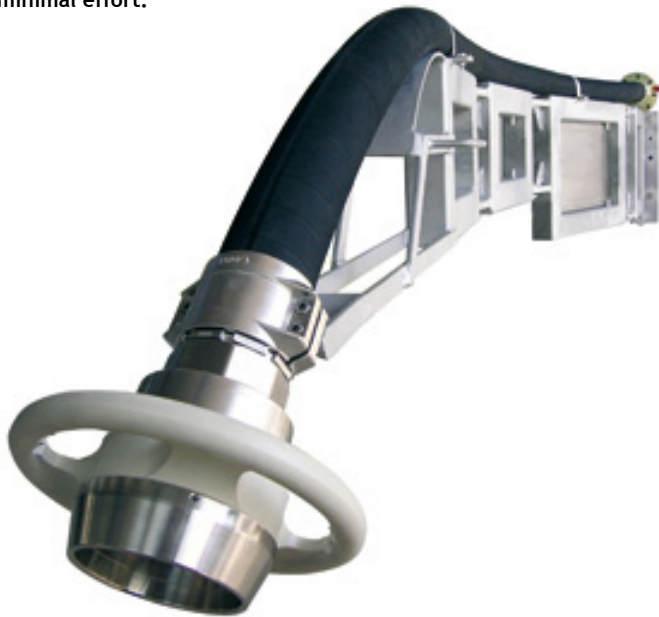

Components

Mounting brackets (wall, foot or other types)
Hose loading arm
Heading section (for top loading, bottom loading, etc.)

Couplings

Breakaway coupling
Dry disconnect coupling
Specialty hose to tanker, truck, or vessel connectors

Construction

Material	Stainless steel 1.4301/1.4401, steel 1.0037 RAL 5002, steel 1.0037 galvanized
Nominal length	6 to 20 feet (2 to 6 meters)
Nominal width	1 to 4 inch (25 to 100 mm)
Bending radius	6 to 17.75 inches (150 to 450 mm)
Types	Top loading, bottom loading, and floor loading





2325 Husky Way • Pacific, MO 63069
(800) 325-3558 • Fax (636) 825-7300
www.husky.com • sales@husky.com

MADE IN THE U.S.A. 

Rev 8/2025